

1. Introduction

The MC-303 PG2 is a thin, ultra long-life PowerG magnetic contact device that is compatible with PowerMaster control panels.

The wireless device includes a built-in reed switch that opens a circuit when the magnet is moved from its normal position.

The detector has the following features:

- Two-way PowerG communication with the control panel
- Front and back cover tamper detection
- LED light signal strength indication during installation
- Discreet transmission of supervision message
- PowerG two-way frequency hopping spread spectrum time-division multiple access (FHSS-TDMA) technology
- Low battery indication



Figure 1: MC-303 PG2

1: Device

2: Magnet

2. Installation

Caution: Service personnel only may install this equipment. Place this device in non-hazardous indoor locations only.

Notes:

Install the MC-303 PG2 in accordance with the Standard for Installation and Classification of Residential Burglar Alarm Systems, UL 1641

To comply with FCC and IC RF exposure compliance requirements, locate the device at a distance of at least 20 cm from all persons during normal operation.

Do not co-locate the antennas used for this product, or operate them in conjunction with any other antenna or transmitter.

2.1. Mounting the MC-303 PG2 (quick installation)

To quick mount the device, complete the following steps.

Note: Do not use this method for UL installations as UL certified devices must be mechanically secured.

1. Peel the release liners off the two strips of double-sided adhesive tape and attach the tape to the back of the device and the magnet. See Figure 2.
2. Place the device on the frame of a window or door and place the magnet on the moving surface of the door or window itself, directed according to the location marks. See Figure 3.

Note: See section [Typical Reed Switch Positions](#) for more information on alignment.

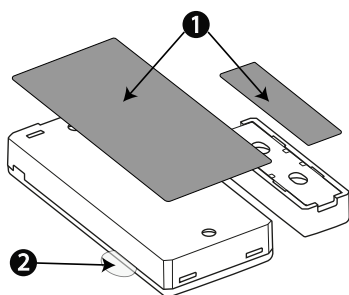

Figure 2: Quick installation

1. Double-sided adhesive tape

2. Enrollment/battery tab

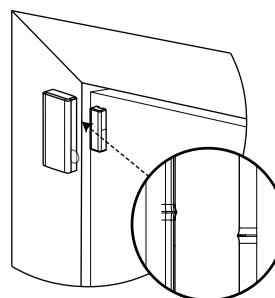

Figure 3:

Device and magnet position on door and door frame

2.2. Mounting the device (screw installation)

To mount the device with screws, complete the following steps:

1. Insert a coin in the slot and twist to remove the cover. See Figure 4.1.
Note: If a coin is not available, insert a 4 mm flat screwdriver into each slot of the plastic cover and twist to open each side. See Figure 4.2.
2. Screw the device base onto the door frame. See Figure 5.
3. Screw the magnet base on to the door, aligning the magnet and device according to the location marks. See Figure 6 and Figure 3.
Note: See section [Typical Reed Switch Positions](#) for more information on alignment.
4. Clip the covers on to the device base and magnet base. See Figure 7.

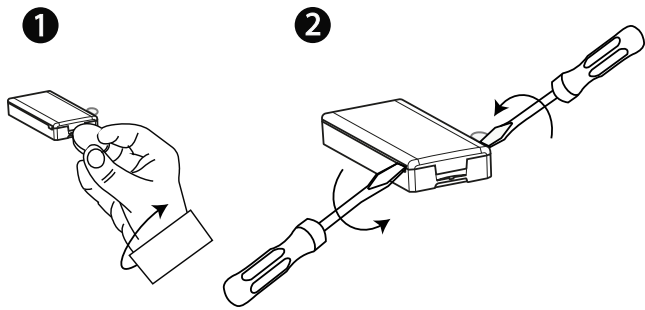

Figure 4: Device cover removal

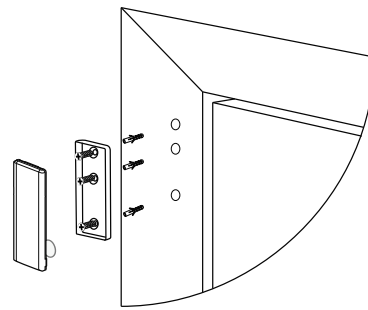

Figure 5: Device screw installation

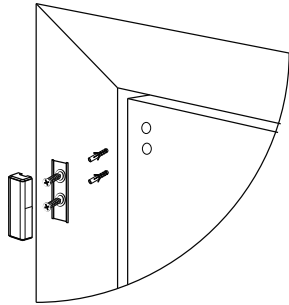

Figure 6: Magnet screw installation

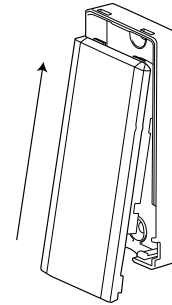

Figure 7: Closing the device cover

2.3. Enrolling the device

To enroll the device, complete the following steps:

1. Pull the battery/enrollment tab to power on the device. See Figure 8.
2. From the installation menu in the control panel, follow the flow chart in Table 1.

Notes:

Refer to the PowerMaster panel installer guide and select **02:ZONES/DEVICES** from the installation menu.

For UL/ULC listed installations use only in conjunction with UL/ULC listed control panels: PowerMaster-10 PG2 and PowerMaster-30 PG2.

When enrolling an MC-303 PG2 detector to PowerMaster panels with version 19.4 or earlier, enroll the detector as MC-302 magnetic contact detector, **ID:100-XXXX**. The device is labeled **Contact Sens** in the panel.

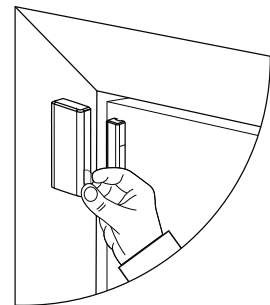

Figure 8: Battery/enrollment tab

Table 1: Enrollment flow chart

Step 1	Step 2	Step 3	Step 4	Step 5	Step 6
From the installer menu, select 02:ZONES/DEVICES	Select ADD NEW DEVICES .	Enroll the device or enter the device ID.	Select the desired zone number.	Configure the location, zone type, and chime parameters.	Configure the detector or select OK , followed by OK to exit.
02:ZONES DEVICES > ADD NEW DEVICES >				Z06: LOCATION	
				Z06: ZONE TYPE	
				Z06: SET CHIME	
				Z06: DEV SETTINGS	
		ENROLL NOW or ENTER	Z06: Contact Sensor ID No.		
		ID: XXX-XXXX >	100-XXXX		

2.4. Replacing the battery

Caution: Do not replace the battery with an incorrect type as it may cause an explosion. Dispose of the used battery according to the manufacturer's instructions and according to local rules and regulations.

Warning: This product contains a coin battery. If it is swallowed, it can cause severe internal burns in just 2 hours and can lead to death. Keep new and used batteries away from children. If the battery compartment does not close securely, stop using the product and keep it away from children. Seek immediate medical attention if you think batteries might have been swallowed or placed inside any part of the body.

To remove the battery, complete the following steps:

1. Remove the device cover. See Figure 4.
2. Wedge a flat head screwdriver under the battery. See Figure 9 (a).
3. Twist the screwdriver using the magnet base as a lever to remove the battery.

To insert the battery, complete the following steps:

1. Insert the battery at an angle while observing battery polarity.
Note: When you insert the battery, the (+) symbol should be visible and not the (-) symbol. See Figure 9 (b).
2. Press down on the battery until it fits into place.

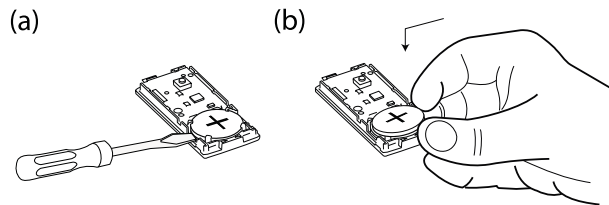

Figure 9: Battery removal and insertion

3. Typical reed switch positions

Table 2 displays the range coverage directions of the MC-303 PG2.

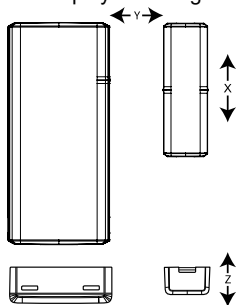

Figure 10: Range coverage directions

Table 2: Typical reed switch positions

Wood		Supports	Iron	
Opening	Closing	Direction	Opening	Closing
24 mm (0.94 in.)	23 mm (0.90 in.)	y	11 mm (0.43 in.)	6 mm (0.23 in.)
25 mm (0.98 in.)*	20 mm (0.78 in.)*		9 mm (0.35 in.)*	5 mm (0.2 in.)*
11 mm (0.43 in.)	6 mm (0.23 in.)	x	15 mm (0.59 in.)	9 mm (0.35 in.)
16 mm (0.63 in.)*	14 mm (0.55 in.)*		17 mm (0.66 in.)*	12 mm (0.46 in.)*
34 mm (1.33 in.)	26 mm (1.02 in.)	Z	27 mm (1.06 in.)	21 mm (0.82 in.)
27 mm (1.06 in.)*	25 mm (0.98 in.)*		18 mm (0.71 in.)*	15 mm (0.58 in.)*

(*) For UL installations

4. Local diagnostics test

Separate the device cover from the base before testing and complete the following steps:

Note: For further instruction, see [Mounting the device \(screw installation\)](#), step 1.

1. Close the cover to return the tamper switch to its normal (undisturbed) position.
2. Open the door or window momentarily to verify detection. Red LED blinks will indicate detection.
3. Wait 2 seconds for the LED to blink three times and compare the LED color to the reception result in Table 3 .

Table 3: Signal strength indication

LED response	Reception
Green LED blinks	Strong
Yellow LED blinks	Good
Red LED blinks	Poor
No blinks	No communication

Important! Reliable reception must be assured. Therefore, poor signal strength is not acceptable. If you receive a poor signal from the detector, relocate it and re-test until a strong signal strength is received . In regions requiring UL-compliant installation, only strong signal strength is permitted.



Note: A strong signal strength is suggested. You must verify the signal strength using the control panel diagnostic test. For detailed diagnostics test instructions, refer to the control panel installer guide.

5. Specifications

Frequency Band (MHz)	433, 868, 915 (in accordance with the prevailing frequency of your region) Note: Only devices in frequency band 915 MHz are UL/ULC listed
-----------------------------	---

Maximum Tx Power	+14 dBm radiated @ 868 MHz +10 dBm radiated @ 433 MHz
Modulation	GFSK
Antenna	Built-in inverted-F antenna
Communication Protocol	PowerG
Supervision	Signaling at 256 s intervals
Battery type	3 V Lithium CR2450 GP, Panasonic, or Duracell battery only
Battery Life	6 years with typical use at room temperature 25°C (77°F). Note: Not verified by UL.
Low Battery Threshold	2 V at room temperature 25°C (77°F)
Operating Temperature	-10°C (14°F) to 55°C (131°F). UL verified range: 0°C (32°F) to 49°C (120°F) only
Storage Temperature	-20°C to 70°C (-4°F to 158°F)
Relative Humidity (RH)	Up to 95% non-condensing, UL verified up to a maximum of 85% RH only
Dimensions (LxWxD)	67 mm x 31 mm x 11 mm (2.6 in. x 1.2 in. x 0.4 in.)
Weight (including battery)	20 g (0.71 oz)
Color	White or brown

6. Compliance with standards

	<p>The MC-303 PG2 complies with the following standards: Europe EN 300220, EN 301489, EN 50130-4, EN 50130-5, EN 61000-6-3, EN 62368-1, EN 50131-1, EN 50131-2-6 Grade 2, Class II and EN 50131-6 Type C</p> <div style="border: 1px solid black; padding: 5px; margin: 5px 0;"> <p>Hereby, Visonic Ltd. declares that the radio equipment type MC-303 PG2 is in compliance with Directive 2014/53/EU. The full text of the EU declaration of conformity is available at the following internet address: http://www.visonic.com/download-center</p> </div> <p>Security Grade: Designed according to EN 50131-1, EN-50131-2-6 and EN-50131-6 Type C: this equipment can be applied in installed systems up to and including Security Grade 2.</p> <p>Environment Class: EN-50131-2-6 Class II</p> <p>Certified by Applica Test & Certification AS in accordance with EN 50131-2-6, EN 50131-5-3, EN 50131-6, EN 50130-4, EN 50130-5. Security Grade 2 and Environmental Class II.</p>
	<p>USA: FCC-CFR 47 Part 15, UL- UL 634 Canada: IC-RSS-247, ULC – C634</p>

Note: This equipment has been tested and found to comply with the limits for a Class B digital device, pursuant to part 15 of the FCC Rules. These limits are designed to provide reasonable protection against harmful interference in a residential installation. This equipment generates, uses and can radiate radio frequency energy and, if not installed and used in accordance with the instructions, may cause harmful interference to radio communications. However, there is no guarantee that interference will not occur in a particular installation. If this equipment does cause harmful interference to radio or television reception, which can be determined by turning the equipment off and on, the user is encouraged to try to correct the interference by one or more of the following measures:

- Reorient or relocate the receiving antenna.
- Increase the separation between the equipment and receiver.
- Connect the equipment into an outlet on a circuit different from that to which the receiver is connected.
- Consult the dealer or an experienced radio / TV technician for help.

Cet équipement a été testé et jugé conforme aux limites s'appliquant à un appareil numérique de classe B, conformément à la Partie 15 des réglementations de la FCC. Ces limites ont été élaborées pour offrir une protection raisonnable contre les interférences nuisibles dans une installation résidentielle.

- This Class B digital apparatus complies with Canadian ICES-003.
- Cet appareil numérique de la classe B est conforme à la norme NMB-003 du Canada.

WARNING! Changes or modifications to this unit not expressly approved by the party responsible for compliance could void the user's authority to operate the equipment.

This device complies with Part 15 of the FCC Rules and with ISSED license-exempt RSS standard(s). Operation is subject to the following two conditions: (1) This device may not cause harmful interference, and (2) this device must accept any interference received, including interference that may cause undesired operation.

Le présent appareil est conforme aux CNR d'ISED applicables aux appareils radio exempts de licence. L'exploitation est autorisée aux deux conditions suivantes : (1) l'appareil ne doit pas produire de brouillage, et (2) l'utilisateur de l'appareil doit accepter tout brouillage radioélectrique subi, même si le brouillage est susceptible d'en compromettre le fonctionnement.

To comply with FCC and IC RF exposure compliance requirements, the device should be located at a distance of at least 20 cm from all persons during normal operation. The antennas used for this product must not be co-located or operated in conjunction with any other antenna or transmitter.

Le dispositif doit être placé à une distance d'au moins 20 cm à partir de toutes les personnes au cours de son fonctionnement normal. Les antennes utilisées pour ce produit ne doivent pas être situées ou exploitées conjointement avec une autre antenne ou transmetteur.

7. Special comments

Even the most sophisticated detectors can sometimes be defeated or may fail to warn due to: DC power failure / improper connection, malicious masking of the lens, tampering with the optical system, decreased sensitivity in ambient temperatures close to that of the human body and unexpected failure of a component part.

The above list includes the most common reasons for failure to detect intrusion, but is by no means comprehensive. It is therefore recommended that the detector and the entire alarm system be checked weekly, to ensure proper performance.

An alarm system should not be regarded as a substitute for insurance. Home and property owners or renters should be prudent enough to continue insuring their lives and property, even though they are protected by an alarm system.



W.E.E.E. Product Recycling Declaration

For information regarding the recycling of this product you must contact the company from which you originally purchased it. If you are discarding this product and not returning it for repair then you must ensure that it is returned as identified by your supplier. This product is not to be thrown away with everyday waste.
Directive 2012/19/EC Waste Electrical and Electronic Equipment.

WARRANTY

Visonic Limited (the "Manufacturer") warrants this product only (the "Product") to the original purchaser only (the "Purchaser") against defective workmanship and materials under normal use of the Product for a period of twelve (12) months from the date of shipment by the Manufacturer.

This Warranty is absolutely conditional upon the Product having been properly installed, maintained and operated under conditions of normal use in accordance with the Manufacturers recommended installation and operation instructions. Products which have become defective for any other reason, according to the Manufacturers discretion, such as improper installation, failure to follow recommended installation and operational instructions, neglect, willful damage, misuse or vandalism, accidental damage, alteration or tampering, or repair by anyone other than the manufacturer, are not covered by this Warranty.

There is absolutely no warranty on software, and all software products are sold as a user license under the terms of the software license agreement included with such Product.

The Manufacturer does not represent that this Product may not be compromised and/or circumvented or that the Product will prevent any death and/or personal injury and/or damage to property resulting from burglary, robbery, fire or otherwise, or that the Product will in all cases provide adequate warning or protection. The Product, properly installed and maintained, only reduces the risk of such events without warning and it is not a guarantee or insurance that such events will not occur.

Conditions to Void Warranty: This warranty applies only to defects in parts and workmanship relating to normal use of the Products. It does not cover:

- * damage incurred in shipping or handling;
- * damage caused by disaster such as fire, flood, wind, earthquake or lightning;
- * damage due to causes beyond the control of the Seller such as excessive voltage, mechanical shock or water damage;
- * damage caused by unauthorized attachment, alterations, modifications or foreign objects being used with or in conjunction with the Products;
- * damage caused by peripherals (unless such peripherals were supplied by the Seller;
- * defects caused by failure to provide a suitable installation environment for the products;
- * damage caused by use of the Products for purposes other than those for which they were designed;
- * damage from improper maintenance;
- * damage arising out of any other abuse, mishandling or improper application of the Products.

Items Not Covered by Warranty: In addition to the items which void the Warranty, the following items shall not be covered by Warranty: (i) freight cost to the repair centre; (ii) customs fees, taxes, or VAT that may be due; (iii) Products which are not identified with the Seller's product label and lot number or serial number; (iv) Products disassembled or repaired in such a manner as to adversely affect performance or prevent adequate inspection or testing to verify any warranty claim. Access cards or tags returned for replacement under warranty will be credited or replaced at the Seller's option.

THIS WARRANTY IS EXCLUSIVE AND EXPRESSLY IN LIEU OF ALL OTHER WARRANTIES, OBLIGATIONS OR LIABILITIES, WHETHER WRITTEN, ORAL, EXPRESS OR IMPLIED, INCLUDING ANY WARRANTY OF MERCHANTABILITY OR FITNESS FOR A PARTICULAR PURPOSE, OR OTHERWISE. IN NO CASE SHALL THE MANUFACTURER BE LIABLE TO ANYONE FOR ANY CONSEQUENTIAL OR INCIDENTAL DAMAGES FOR BREACH OF THIS WARRANTY OR ANY OTHER WARRANTIES WHATSOEVER, AS AFORESAID.

THE MANUFACTURER SHALL IN NO EVENT BE LIABLE FOR ANY SPECIAL, INDIRECT, INCIDENTAL, CONSEQUENTIAL OR PUNITIVE DAMAGES OR FOR LOSS, DAMAGE, OR EXPENSE, INCLUDING LOSS OF USE, PROFITS, REVENUE, OR GOODWILL, DIRECTLY OR INDIRECTLY ARISING FROM PURCHASER'S USE OR INABILITY TO USE THE PRODUCT, OR FOR LOSS OR DESTRUCTION OF OTHER PROPERTY OR FROM ANY OTHER CAUSE, EVEN IF MANUFACTURER HAS BEEN ADVISED OF THE POSSIBILITY OF SUCH DAMAGE.

THE MANUFACTURER SHALL HAVE NO LIABILITY FOR ANY DEATH, PERSONAL AND/OR BODILY INJURY AND/OR DAMAGE TO PROPERTY OR OTHER LOSS WHETHER DIRECT, INDIRECT, INCIDENTAL, CONSEQUENTIAL OR OTHERWISE, BASED ON A CLAIM THAT THE PRODUCT FAILED TO FUNCTION. HOWEVER, IF THE MANUFACTURER IS HELD LIABLE, WHETHER DIRECTLY OR INDIRECTLY, FOR ANY LOSS OR DAMAGE ARISING UNDER THIS LIMITED WARRANTY, THE MANUFACTURER'S MAXIMUM LIABILITY (IF ANY) SHALL NOT IN ANY CASE EXCEED THE PURCHASE PRICE OF THE PRODUCT INVOLVED, WHICH SHALL BE FIXED AS LIQUIDATED DAMAGES AND NOT AS A PENALTY, AND SHALL BE THE COMPLETE AND EXCLUSIVE REMEDY AGAINST THE MANUFACTURER. SOME JURISDICTIONS DO NOT ALLOW THE EXCLUSION OR LIMITATION OF INCIDENTAL OR CONSEQUENTIAL DAMAGES, SO THESE LIMITATIONS MAY NOT APPLY UNDER CERTAIN CIRCUMSTANCES.

When accepting the delivery of the Product, the Purchaser agrees to the said conditions of sale and warranty and he recognizes having been informed of.

The Manufacturer shall be under no liability whatsoever arising out of the corruption and/or malfunctioning of any telecommunication or electronic equipment or any programs.

The Manufacturers obligations under this Warranty are limited solely to repair and/or replace at the Manufacturer's discretion any Product or part thereof that may prove defective. Any repair and/or replacement shall not extend the original Warranty period. The Manufacturer shall not be responsible for dismantling and/or reinstallation costs. To exercise this Warranty the Product must be returned to the Manufacturer freight pre-paid and insured. All freight and insurance costs are the responsibility of the Purchaser and are not included in this Warranty.

This warranty shall not be modified, varied or extended, and the Manufacturer does not authorize any person to act on its behalf in the modification, variation or extension of this warranty. This warranty shall apply to the Product only. All products, accessories or attachments of others used in conjunction with the Product, including batteries, shall be covered solely by their own warranty, if any. The Manufacturer shall not be liable for any damage or loss whatsoever, whether directly, indirectly, incidentally, consequentially or otherwise, caused by the malfunction of the Product due to products, accessories, or attachments of others, including batteries, used in conjunction with the Products. This Warranty is exclusive to the original Purchaser and is not assignable.

This Warranty is in addition to and does not affect your legal rights. Any provision in this warranty which is contrary to the Law in the state or country were the Product is supplied shall not apply.

Governing Law: This disclaimer of warranties and limited warranty are governed by the domestic laws of Israel.

Warning

The user must follow the Manufacturer's installation and operational instructions including testing the Product and its whole system at least once a week and to take all necessary precautions for his/her safety and the protection of his/her property.

* In case of a conflict, contradiction or interpretation between the English version of the warranty and other versions, the English version shall prevail.
4/18



D-307432



EMAIL: info@visonic.com
INTERNET: www.visonic.com
D-307432 MC-303 PG2 Rev. 4, 12/23

© 2023 Johnson Controls. All rights reserved. JOHNSON CONTROLS and VISONIC are trademarks and/or registered trademarks. Unauthorized use is strictly prohibited.