

MODEL QTC2 AIR-COOLED SCROLL CHILLERS

15 ton to 46 ton
53 kW to 162 kW
60 Hz
R-410A

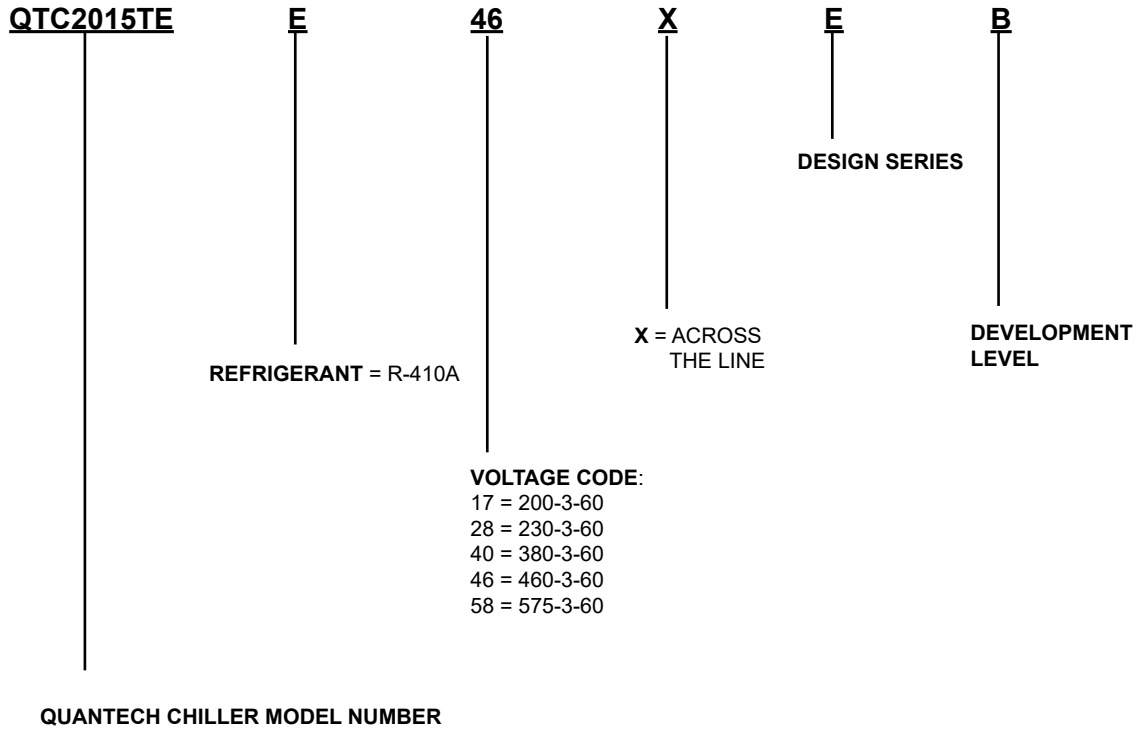

Nomenclature



Approvals

- ASME Boiler and Pressure Vessel Code – Section VIII Division 1.
- AHRI Standard 550/590.
- UL 1995 – Heating and Cooling Equipment
- ASHRAE 15 – Safety Code for Mechanical Refrigeration
- ASHRAE Guideline 3 – Reducing Emission of Halogenated Refrigerants in Refrigeration and Air-Conditioning Equipment and Systems
- NEC – National Electrical Code
- OSHA – Occupational Safety and Health Act



Products are produced at a facility whose quality-management systems are ISO9001 certified.

Table Of Contents

INTRODUCTION	5
MICROCOMPUTER CONTROL CENTER	7
ACCESSORIES AND OPTIONS	10
DESIGN PARAMETERS	13
WATER PRESSURE DROP	14
PHYSICAL DATA AND NOMINAL RATINGS	16
PART LOAD RATINGS	18
UNIT DIMENSIONS - ENGLISH	20
UNIT DIMENSIONS - METRIC	34
ISOLATOR DETAILS	48
ELECTRICAL DATA - 60HZ	52
ELECTRICAL NOTES	54
CIRCUIT BREAKER CALCULATIONS	56
POWER WIRING	57
CONTROL WIRING	60
APPLICATION DATA	61
GUIDE SPECIFICATIONS	64

Performance data provided in this document was created in accordance with Quantech software: **YW version 17.01.**

THIS PAGE IS INTENTIONALLY LEFT BLANK.

Introduction

Quantech™ is proud to present the Model QTC2 Air-Cooled Scroll Chiller.

The QTC2 Air-Cooled Scroll Chillers provide chilled water for all air conditioning applications using central station air handling or terminal units. They are completely self-contained and are designed for outdoor (roof or ground level) installation. Each unit includes hermetic scroll compressors, a liquid cooler, air-cooled condenser, a charge of refrigerant R-410A, and a weather resistant microprocessor control center, all mounted on a rugged, formed-steel base.

GENERAL

The 15 ton to 46 ton (53 kW to 162 kW) QTC2 models are shipped complete from the factory ready for installation and use.

The unit is pressure-tested, evacuated, and fully charged with Refrigerant-410A and includes an initial oil charge. After assembly, a complete operational test is performed with water flowing through the cooler to assure that the refrigeration circuit operates correctly.

The unit structure is heavy-gauge, galvanized steel. The steel is coated with baked-on powder paint, which, when subjected to ASTM B117 1000 hour, salt spray testing, yields a minimum ASTM 1654 rating of "6". Corrosion resistant wire mesh panels are added to protect the condenser coil from incidental damage and restrict unauthorized access to internal components. Unit also includes service isolation valves as standard. Units are designed in accordance with NFPA 70 (National Electric Code), ASHRAE/ANSI 15 Safety code for mechanical refrigeration, ASME, listed and labeled with Intertek Testing Services (ETL) and rated in accordance with the latest version of AHRI Standard 550/590.

COMPRESSORS

The chiller has suction-gas cooled, hermetic, scroll compressors. The compressors incorporate a scroll design that is compliant in both the axial and radial direction. All rotating parts are statically and dynamically balanced. A large internal volume and oil reservoir provides greater liquid tolerance. Compressor crankcase heaters are also included for extra protection against liquid migration.

COOLER

Brazed plate heat exchangers are UL (Underwriters Laboratories) listed. Installing contractor must include accommodations in the chilled water piping to allow proper drainage and venting of the heat exchanger. Water inlet and outlet connections are grooved for compatibility with factory supplied ANSI/AWWA C-606 connections.

The cooler is equipped with a heater controlled by a separate thermostat. The heater provides freeze protection for the cooler down to -20°F (-29°C) ambient. The cooler is covered with 3/4" (19mm) flexible, closed-cell, foam insulation (K≈0.25).

Introduction (Cont'd)

A 40 mesh strainer (0.5 and 1.5 mm) is recommended upstream of the heat exchanger to prevent clogging.

CONDENSER

Coils – Fin and tube condenser coils of seamless, internally-enhanced, high-condensing-coefficient, corrosion resistant copper tubes are arranged in staggered rows, mechanically expanded into aluminum fins. Integral subcooling is included. The design working pressure of the coil is 650 PSIG (45 barg).

Low Sound Fans – The condenser fans are composed of corrosion resistant aluminum hub and composite blades molded into a low noise airfoil section. They are designed for maximum efficiency and are statically and dynamically balanced for vibration-free operation. They are directly driven, and positioned for vertical air discharge. The fan guards are constructed of heavy-gauge, rust-resistant, PVC (polyvinyl chloride)-coated steel wire.

Motors – The fan motors are Totally Enclosed Air-Over, squirrel-cage type, current protected. They feature ball bearings that are double-sealed and permanently lubricated.

MicroComputer Control Center

All controls are contained in a NEMA 3R powder painted steel cabinet with a gasketed door and include the following features:

- Liquid Crystal Display (LCD) with Light Emitting Diode (LED) backlighting for outdoor viewing:
 - Two display lines
 - Twenty characters per line
- Color-coded 12-button non-tactile keypad with two sections:
 - **DISPLAY/PRINT** the following typical information:
 - Chilled liquid temperatures
 - Ambient temperature
 - System pressures (each circuit)
 - Operating hours and starts (each compressor)
 - **PRINT** displays the following information on the liquid crystal display:
 - Operating data for the systems
 - History of fault shutdown data for up to the last six fault shutdown conditions
 - An RS-232 port, in conjunction with this press-to-print button, enables hard copies to be printed via a separate printer
 - **ENTRY** section to:
 - Enter setpoints or modify system values
 - **SETPOINTS** updating can be performed to:
 - Chill liquid temperature setpoint and range
 - Remotely reset temperature range
 - Set daily schedule/holiday for start/stop
 - Manually override for servicing
 - Low and high ambient cutouts
 - Number of compressors
 - Low liquid temperature cutout

MicroComputer Control Center (Cont'd)

- Low suction pressure cutout
- High discharge pressure cutout
- Anti-recycle timer (compressor start cycle time)
- Anti-coincident timer (delay compressor starts)
- **UNIT** section to set the following rules:
 - Set time
 - Set unit options
- **UNIT ON/OFF** switch

The microprocessor control center can display the following information:

- Return and leaving liquid temperature
- Low leaving liquid temperature cutout setting
- Low ambient temperature cutout setting
- Outdoor air temperature
- English or Metric data
- Suction pressure cutout setting
- Each system suction pressure
- Discharge pressure (optional)
- Liquid Temperature Reset via a Quantech ISN DDC or Building Automation System (by others) via:
 - A pulse width modulated (PWM) input as standard
 - A 4-20 milliamp or 0 -10 VDC input, or contact closure with the optional B.A.S. interface option
- Anti-recycle timer status for each system
- Anti-coincident system start-timer condition
- Compressor-run status
- No-cooling load condition
- Day, date, and time
- Daily start or stop times
- Holiday status
- Automatic or manual system lead or lag control

MicroComputer Control Center (Cont'd)

- Lead system definition
- Compressor starts and operating hours (each compressor)
- Status of hot gas valves, evaporator heater and fan operation
- Run permissive status
- Number of running compressors
- Liquid-solenoid valve status
- Load and unload timer status
- Water pump status

Accessories and Options

All options are factory installed unless otherwise noted.

ELECTRICAL OPTIONS

Single-Point Non-Fused Disconnect Switch – Unit-mounted disconnect switch with external, lockable handle (in compliance with Article 440-14 of NEC), can be supplied to isolate the unit power voltage for servicing. Separate external fusing must be supplied, by others in the power wiring, which must comply with the National Electrical Code and/or local codes.

Single-Point Circuit Breaker – A unit mounted circuit breaker with external, lockable handle (in compliance with NEC Article 440-14), can be supplied to isolate the power for servicing. (This option includes the Single-Point Power connection.)

Control Transformer – This converts unit power voltage to 115-1-60 or 115-1-50 if 50Hz is selected (0.5 or 1.0 KVA capacity). Factory mounting includes primary and secondary wiring between the transformer and the control panel.

CONTROL OPTIONS

Ambient Kit (Low) – Standard units operate to 25°F (-4°C). This accessory includes all necessary components to permit chiller operation to 0°F (-18°C). (This option includes the Discharge Pressure Transducer/Readout Capability option.) For correct head pressure control in applications below 25°F (-4°C), where wind gusts may exceed five mph, it is recommended that Optional Condenser Louvered Enclosure Panels also be included.

Ambient Kit (High) – This is required if units are to operate when the ambient temperature is above 110°F (43°C). Includes discharge pressure transducers. (This option includes the Discharge Pressure Transducer/Readout Capability option.) (Field-Mounted.)

Language LCD And Keypad Display – Spanish, French, and German unit LCD controls and keypad display are available. Standard language is English.

Discharge Pressure Transducers And Readout Capability – The addition of pressure transducers allows models to sense and display discharge pressure. This is recommended for glycol chilling applications. (This option is included with either the low or high ambient kits.)

Suction Pressure Transducers – Permits unit to sense and display suction pressure. This capability is standard.

COMPRESSOR, PIPING, EVAPORATOR OPTIONS

Low Temperature Glycol – Required for glycol chilling below 30°F (-1°C) leaving glycol temperature. Option includes resized thermal expansion valve.

Chicago Code Relief Valves – Unit is provided with relief valves to meet Chicago code requirements.

Service Isolation Valve – Service isolation valves are standard to unit. This includes a system high pressure relief valve or internal compressor relief mechanism in compliance with ASHRAE 15.

Accessories and Options (Cont'd)

Hot Gas By-Pass – Permits continuous, stable operation at capacities below the minimum step of compressor unloading to as low as 5% capacity (depending on both the unit and operating conditions) by introducing an artificial load on the cooler. Hot gas by-pass is installed on only refrigerant system #1 on two-circuit units.

Flanges (ANSI/AWWA C-606 coupling) – Consists of two (2) flange adapters for grooved end pipe (standard 150 psi [10.5 barg] cooler).

Flow Switch – The flow switch or its equivalent must be furnished with each unit.

- **150 PSIG (10.5 barg) DWP** – For standard units. a vaporproof SPDT, NEMA 4X switch (150 PSIG [10.5 barg] DWP), -20°F to 250°F (-29°C to 121°C), with 1" NPT connection for upright mounting in horizontal pipe is installed. (Field-mounted.)

Differential Pressure Switch – Alternative to the above mentioned flow switches. A 300 psig (21 barg) maximum working pressure, SPDT 5 amp 125/250VAC switch will be installed. The range is 3-45 PSIG (0.2-3 barg), deadband 0.5 - 0.8 psi (0.003 - 0.005 barg), with 1/4" NPTE Pressure Connections.

CONDENSER AND CABINET OPTIONS

Condenser coil protection against corrosive environments is available by choosing any of the following options. For additional application recommendations, contact your local Quantech office.

Pre-Coated Fin Condenser Coils – The unit's coils are constructed with epoxy coated aluminum fins. This can provide corrosion resistance comparable to copper-fin coils in typical seashore locations. Either these or the post-coated coils (below), are recommended for units being installed at the seashore or where salt spray may hit the unit.

Post-Coated Dipped Condenser Coils – The unit's coils are constructed with dipped-cured condenser coils. This is the choice for corrosive applications (with the exception of strong alkalis, oxidizers and wet bromine, chlorine and fluorine in concentrations greater than 100 ppm).

Enclosure Panels (Unit) – Tamperproof enclosure panels prevent unauthorized access to units. Enclosure panels can provide an aesthetically pleasing alternative to expensive fencing.

Louvered Panels (Full Unit) – Louvered panels surround the front, back, and sides of the unit. They prevent unauthorized access and visually screen unit components. Unrestricted air flow is permitted through generously sized louvered openings. This option is applicable for any outdoor design ambient temperature up to 115°F (46°C). Recommended for use with the Low Ambient kit where wind gusts may exceed five mph (eight kph).

Ultra Quiet Fans – The chiller is equipped with specially designed fans and motors to provide lower sound levels yet retain appropriate airflow. The result is reduced fan generated sound with minimal effect on the chiller capacity or efficiency at standard AHRI conditions. The fans are three-bladed for 60Hz and five-bladed for 50Hz.

Vibration Isolators – Level adjusting, spring type 1" (25.4 mm) or 2" (50.8 mm) deflection or neoprene pad isolators for mounting under unit base rails. (Field-mounted.)

THIS PAGE IS INTENTIONALLY LEFT BLANK.

Design Parameters

QTC2 ENGLISH						
MODEL	LEAVING WATER TEMPERATURE (°F)		COOLER FLOW (GPM)		AIR ON CONDENSER (°F)	
	MIN	MAX	MIN	MAX	MIN	MAX
	015T	40	55	10	150	0
020T	40	55	10	150	0	125
025T	40	55	10	150	0	125
030T	40	55	10	150	0	125
035T	40	55	40	200	0	125
040T	40	55	40	200	0	125
045T	40	55	60	300	0	125
QTC2 SI UNITS						
MODEL	LEAVING WATER TEMPERATURE (°C)		COOLER FLOW (L/S)		AIR ON CONDENSER (°C)	
	MIN	MAX	MIN	MAX	MIN	MAX
	015T	4.4	12.8	0.6	9.5	-17.7
020T	4.4	12.8	0.6	9.5	-17.7	51.7
025T	4.4	12.8	0.6	9.5	-17.7	51.7
030T	4.4	12.8	0.6	9.5	-17.7	51.7
035T	4.4	12.8	2.5	12.6	-17.7	51.7
040T	4.4	12.8	2.5	12.6	-17.7	51.7
045T	4.4	12.8	3.8	18.9	-17.7	51.7

NOTES:

1. For leaving brine temperature below 40°F (4.4°C), contact your nearest Quantech Sales Office for application requirements.
2. For leaving water temperature higher than 55°F (12.8°C), contact the nearest Quantech Sales Office for application guidelines.
3. The evaporator is protected against freezing to -20°F (-28.8°C) with an electric heater as standard.
4. For operation at temperatures below 25°F (-3.9°C), the optional Low Ambient Kit will need to be installed on the system (for QTC2040T-045T models only).
5. For operation at temperatures above 115°F (46.1°C), the optional High Ambient Kit will need to be installed on the system.

Water Pressure Drop

QTC2 ENGLISH EVAPORATOR PRESSURE DROP CURVE

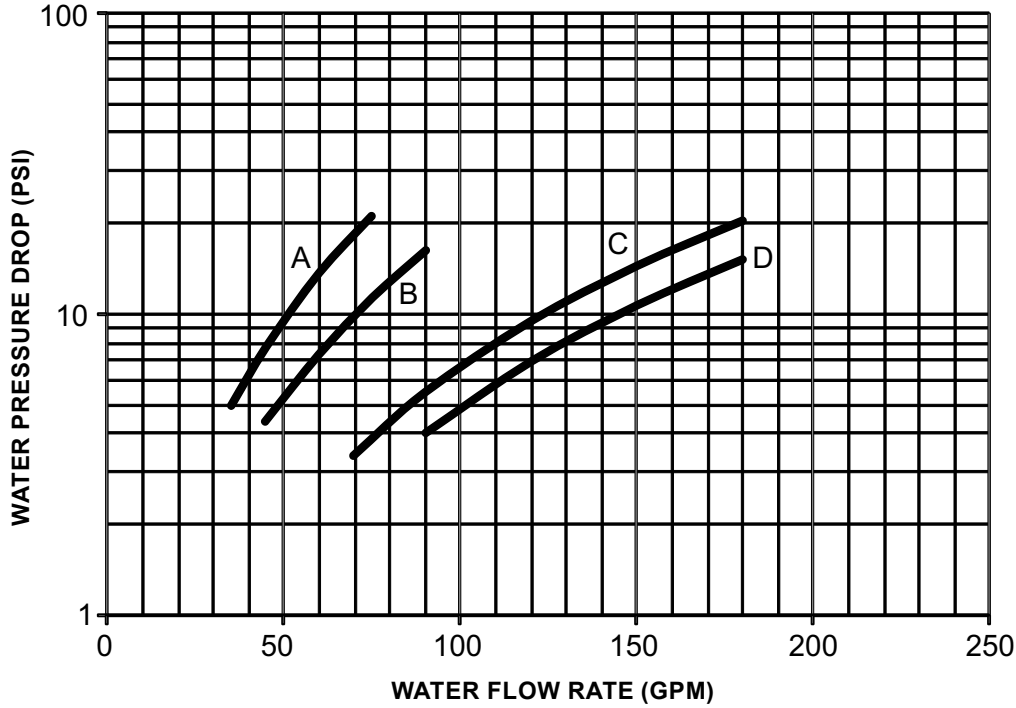

LD18667

EVAPORATOR CURVE	CHILLER MODEL
A	QTC2015T
B	QTC2020T
B	QTC2025T
B	QTC2030T
C	QTC2035T
D	QTC2040T
C	QTC2045T

Water Pressure Drop (Cont'd)

QTC2 SI EVAPORATOR PRESSURE DROP CURVE

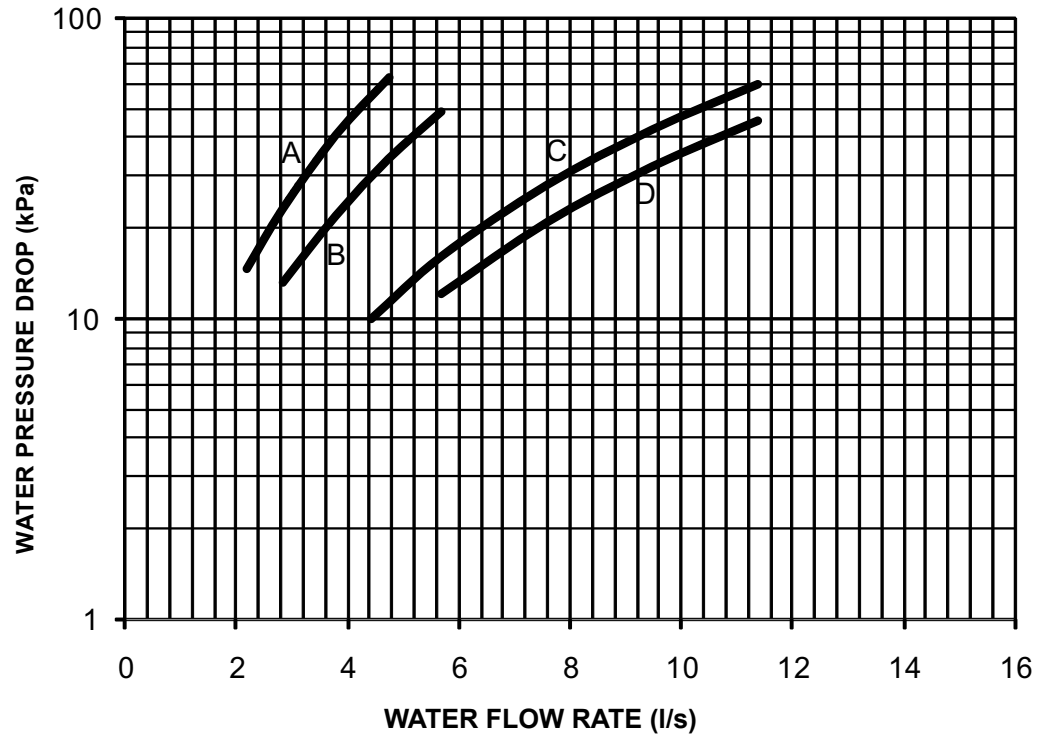

LD18668

EVAPORATOR CURVE	CHILLER MODEL
A	QTC2015T
B	QTC2020T
B	QTC2025T
B	QTC2030T
C	QTC2035T
D	QTC2040T
C	QTC2045T

Physical Data and Nominal Ratings

ENGLISH

REFRIGERANT R-410A		QTC2						
		STANDARD EFFICIENCY UNITS						
		015T	020T	025T	030T	035T	040T	045T
Length, in		109.8	109.8	119.6	119.6	144.8	144.8	144.8
Width, in		44.7	44.7	44.7	44.7	90.6	90.6	90.6
Height, in		46.1	46.1	50	50	47.8	47.8	62.6
NOMINAL RATINGS								
Tons		15.5	18.7	25.6	28.6	37.2	39.4	46.2
kW		18.3	22.2	30.4	32.6	44.2	46.6	54.6
EER, Btu/W.h		10.1	10.1	10.1	10.5	10.1	10.2	10.2
IPLV, Btu/W.h		14.7	15.5	13.7	14.5	14.5	14.7	15.1
Number of Refrigerant Circuits		1	1	1	1	2	2	2
Refrigerant Charge, Opt, R-410A (lb) Circuit 1/Circuit 2		25	30	45	50	35/35	40/35	45/45
Oil Charge, gallons ckt1/ckt2		1.8	1.8	1.7	2.2	1.8/1.8	1.8/1.8	1.7/1.7
Shipping Weight	Aluminum Fin Coils, lb	1454	1567	1798	2034	2942	2968	3170
Operating Weight	Aluminum Fin Coils, lb	1481	1597	1835	2077	2967	3000	3208
NOMINAL COMPRESSOR CAPACITY								
Compressor 1		8	10	15	15	10	12	13
Compressor 2		8	10	13	15	10	12	13
Compressor 3		–	–	–	–	–	–	–
Compressor 4		–	–	–	–	10	10	13
Compressor 5		–	–	–	–	10	10	13
Compressor 6		–	–	–	–	–	–	–
CONDENSER								
Total Face Area ft ²		34.7	34.7	43.5	43.5	87	87	116
Number of Rows Deep	Circuit 1	2	3	3	3	2	2	3
	Circuit 2	–	–	–	–	2	2	3
Fins per Inch		17	17	13	13	17	17	17
CONDENSER FANS, LOW SOUND								
Number of Fans	Circuit 1	2	2	2	2	2	2	2
	Circuit 2	–	–	–	–	2	2	2
Fan Power, hp/fan		0.5	0.5	1.5	1.5	1.4	1.4	1.7
Fan, rpm		1075	1075	1150	1150	1150	1150	1150
Total Chiller, cfm		11426	10670	24600	24600	47360	47360	52000
CONDENSER FANS, ULTRA QUIET								
Number of Fans	Circuit 1	2	2	2	2	2	2	2
	Circuit 2	–	–	–	–	2	2	2
Fan Power, hp/fan		–	–	1.5	1.5	1.4	1.4	1.7
Fan, rpm		–	–	820	820	820	820	820
Total Chiller, cfm		–	–	24600	24600	47360	47360	52000
EVAPORATOR								
Water Volume, gal		1.2	1.2	1.2	1.2	2.7	2.7	3.5
Maximum Water Side Pressure, psig		300	300	300	300	300	300	300
Maximum Refrig Side Pressure, psig		450	450	450	450	450	450	450
Minimum Chiller Water Flow, gpm		10	10	10	10	40	40	60
Maximum Chiller Water Flow, gpm		150	150	150	150	200	200	300
Water Connection Size, in		2	2	2	2	3	3	3

Physical Data and Nominal Ratings (Cont'd)

SI

REFRIGERANT R-410A		QTC2						
		STANDARD EFFICIENCY UNITS						
		015T	020T	025T	030T	035T	040T	045T
Length, mm		2789	2789	3038	3038	3678	3678	3678
Width, mm		1135	1135	1135	1135	2301	2301	2301
Height, mm		1171	1171	1270	1270	1214	1214	1590
NOMINAL RATINGS								
Capacity, kW		45.6	55.0	75.3	84.3	109.6	115.8	136.0
Power Input, kW		14.5	18.0	23.7	25.7	34.7	36.6	42.0
EER, kW/kW		3.1	3.1	3.2	3.3	3.2	3.2	3.2
IPLV, kW/kW		4.6	5.0	4.4	4.7	4.9	4.9	4.7
Number of Refrigerant Circuits		1	1	1	1	2	2	2
Refrigerant Charge, Opt, R-410A (kg) Circuit 1/Circuit 2		11.3	13.6	20.4	22.7	15.9/15.9	18.1/15.9	20.4/20.4
Oil Charge, liters ckt1/ckt2		6.8	6.8	6.4	8.3	6.8/6.8	6.8/6.8	6.4/6.4
Shipping Weight	Aluminum Fin Coils, kg	660	711	816	923	1334	1346	1438
Operating Weight	Aluminum Fin Coils, kg	672	724	832	942	1346	1361	1455
NOMINAL COMPRESSOR CAPACITY								
Compressor 1		8	10	15	15	10	12	13
Compressor 2		8	10	13	15	10	12	13
Compressor 3		–	–	–	–	–	–	–
Compressor 4		–	–	–	–	10	10	13
Compressor 5		–	–	–	–	10	10	13
Compressor 6		–	–	–	–	–	–	–
CONDENSER								
Total Face Area m ²		3.2	3.2	4.0	4.0	8.1	8.1	10.8
Number of Rows Deep	Circuit 1	2	3	3	3	2	2	3
	Circuit 2	–	–	–	–	2	2	3
Fins per Inch		17	17	13	13	17	17	17
CONDENSER FANS, LOW SOUND								
Number of Fans	Circuit 1	2	2	2	2	2	2	2
	Circuit 2	–	–	–	–	2	2	2
Fan Power, kW/fan		0.3	0.3	0.9	0.9	0.8	0.8	1.0
Fan, rpm		896	896	950	950	950	950	950
Total Chiller, m ³ /h		16171	15101	34816	34816	67029	67029	73622
CONDENSER FANS, ULTRA QUIET								
Number of Fans	Circuit 1	–	–	2	2	2	2	2
	Circuit 2	–	–	–	–	2	2	2
Fan Power, kW/fan		–	–	0.9	0.9	0.8	0.8	1.0
Fan, RPM		–	–	690	690	690	690	690
Total Chiller, m ³ /h		–	–	34816	34816	67029	67029	73622
EVAPORATOR								
Water Volume, l		4.5	4.5	4.5	4.5	10.2	10.2	13.2
Maximum Water Side Pressure, barg		20.7	20.7	20.7	20.7	20.7	20.7	20.7
Maximum Refrig Side Pressure, barg		31	31	31	31	31	31	31
Minimum Chiller Water Flow, l/s		0.6	0.6	0.6	0.6	2.5	2.5	3.8
Maximum Chiller Water Flow, l/s		9.5	9.5	9.5	9.5	12.6	12.6	18.9
Water Connection Size, in		2	2	2	2	3	3	3

Part Load Ratings

ENGLISH

QTC2015T				
% DISPL.	TONS	KW	AMBIENT (°F)	UNIT EER
100	15.5	18.3	95.0	10.1
50	9.1	6.8	70.2	16.0
IPLV=14.6				

QTC2020T				
% DISPL.	TONS	KW	AMBIENT (°F)	UNIT EER
100	18.7	22.2	95.0	10.1
50	11.5	8.2	72.1	16.9
IPLV=15.5				

QTC2025T				
% DISPL.	TONS	KW	AMBIENT (°F)	UNIT EER
100	25.6	30.3	95.0	10.1
50	15.7	12.8	71.9	14.7
IPLV=13.7				

QTC2030T				
% DISPL.	TONS	KW	AMBIENT (°F)	UNIT EER
100	28.6	32.6	95.0	10.5
50	16.7	12.7	70.0	15.7
IPLV=14.5				

QTC2035T				
% DISPL.	TONS	KW	AMBIENT (°F)	UNIT EER
100	37.2	44.2	95.0	10.1
75	30.0	30.0	83.3	12.0
50	21.1	17.0	69.0	14.9
25	11.5	8.0	55.0	17.3
IPLV=14.4				

QTC2040T				
% DISPL.	TONS	KW	AMBIENT (°F)	UNIT EER
100	39.4	46.6	95.0	10.2
75	31.5	30.8	82.9	12.3
50	22.4	17.7	69.1	15.2
25	11.6	7.9	55.0	17.5
IPLV=14.7				

QTC2045T				
% DISPL.	TONS	KW	AMBIENT (°F)	UNIT EER
100	46.2	54.6	95.0	10.2
75	37.3	37.4	83.4	12.0
50	26.6	21.0	69.5	15.2
25	15.1	9.5	55.0	19.1
IPLV=15.0				

Part Load Ratings (Cont'd)

SI

QTC2015T				
% DISPL.	TONS	KW	AMBIENT (°F)	UNIT EER
100	13.0	14.5	95.0	10.7
50	7.6	5.4	70.2	17.0
IPLV=15.6				

QTC2020T				
% DISPL.	TONS	KW	AMBIENT (°F)	UNIT EER
100	15.6	17.9	95.0	10.3
50	9.7	6.2	72.0	18.8
IPLV=17.1				

QTC2025T				
% DISPL.	TONS	KW	AMBIENT (°F)	UNIT EER
100	21.4	23.7	95.0	10.8
50	13.1	9.7	71.6	15.8
IPLV=15.0				

QTC2030T				
% DISPL.	TONS	KW	AMBIENT (°F)	UNIT EER
100	24.0	25.7	95.0	11.1
50	13.8	9.6	69.6	17.3
IPLV=15.9				

QTC2035T				
% DISPL.	TONS	KW	AMBIENT (°F)	UNIT EER
100	31.2	34.7	95.0	10.7
75	25.1	22.8	83.3	13.2
50	17.6	12.4	68.8	17.1
25	9.7	5.4	55.0	21.5
IPLV=16.7				

QTC2040T				
% DISPL.	TONS	KW	AMBIENT (°F)	UNIT EER
100	32.9	36.6	95.0	10.8
75	26.2	23.4	82.8	13.5
50	18.6	13.1	68.9	17.0
25	9.7	5.4	55.0	21.7
IPLV=16.8				

QTC2045T				
% DISPL.	TONS	KW	AMBIENT (°F)	UNIT EER
100	38.7	42.0	95.0	11.1
75	31.0	27.9	83.0	13.3
50	21.7	15.6	68.7	16.7
25	12.0	7.2	55.0	19.9
IPLV=16.2				

Unit Dimensions - English

QTC2015T

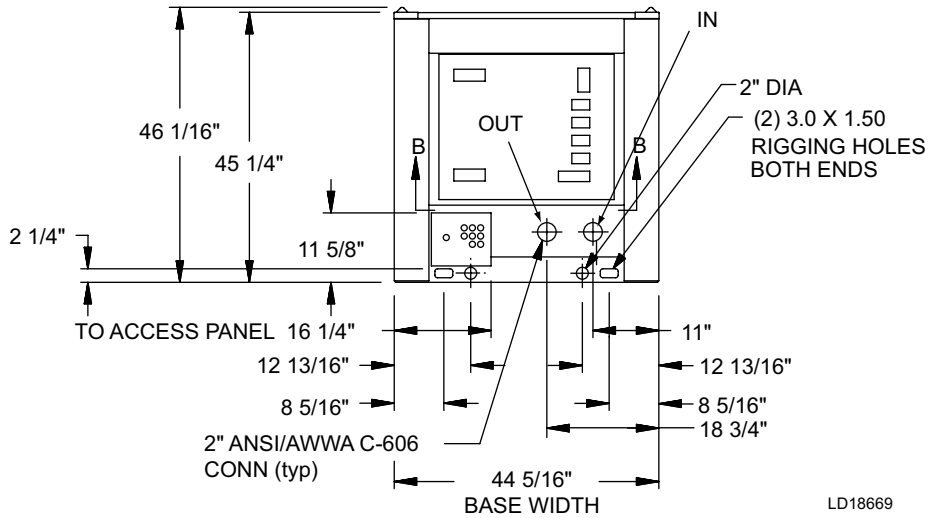
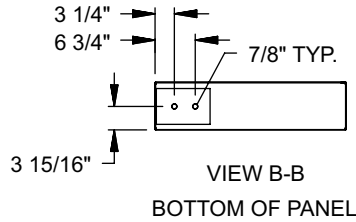

LD18669

NOTE:

Placement on a level surface of free of obstructions (including snow, for winter operation) or air circulation ensures rated performance, reliable operation, and ease of maintenance. Site restrictions may compromise minimum clearances indicated below, resulting in unpredictable airflow patterns and possible diminished performance. The unit controls will optimize operation without nuisance high-pressure safety cut-outs; however, the system designer must consider potential performance degradation. Access to the unit control center assumes the unit is no higher than on spring isolators. Recommended minimum clearances: Side to wall – 6 ft; rear to wall – 6 ft; control panel to end wall – 4ft'; top – no obstructions allowed; distance between adjacent units – 10 ft. No more than one adjacent wall may be higher than the unit.

Unit Dimensions - English (Cont'd)

QTC2015T

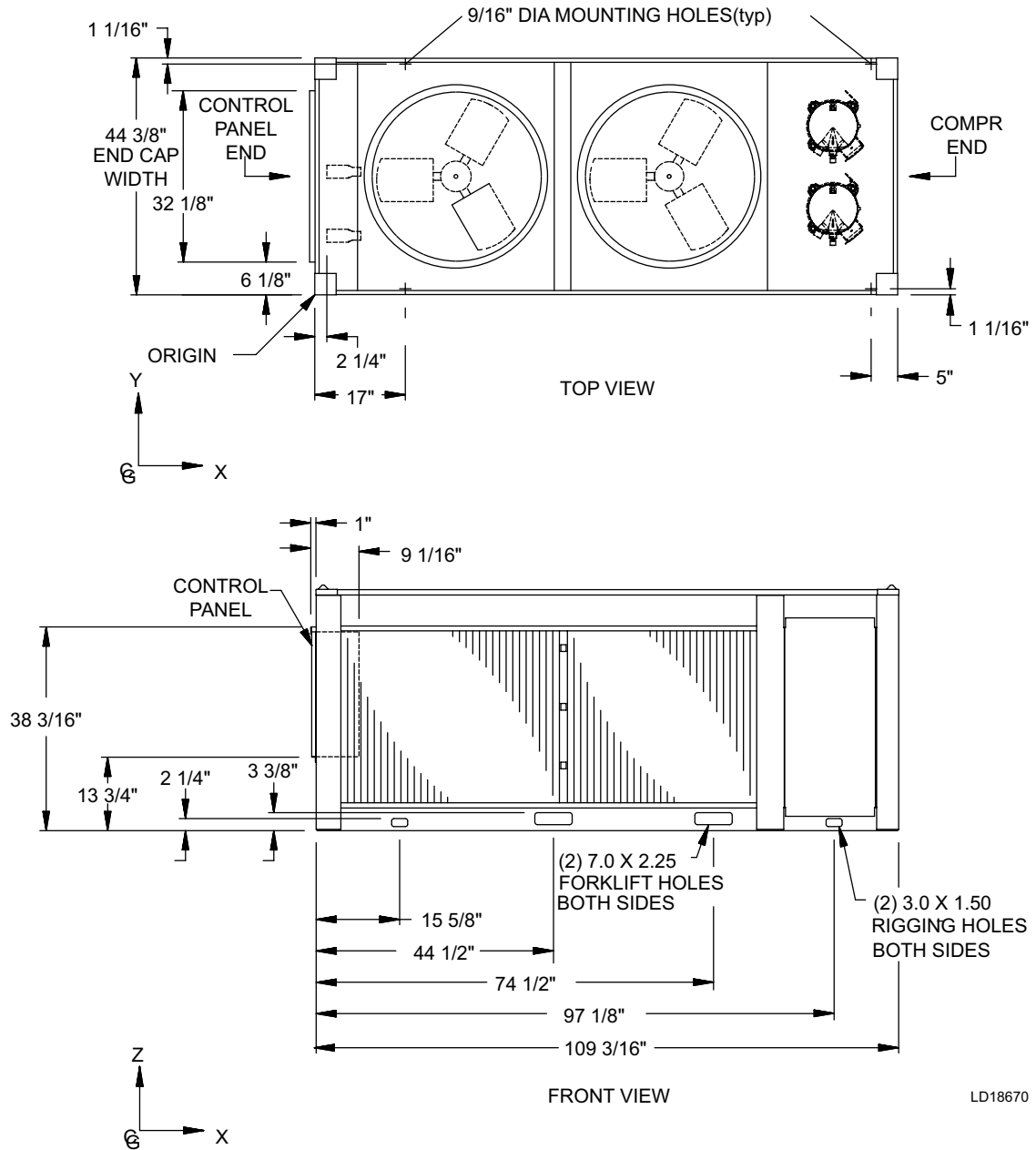

Unit Dimensions - English (Cont'd)

QTC2020T

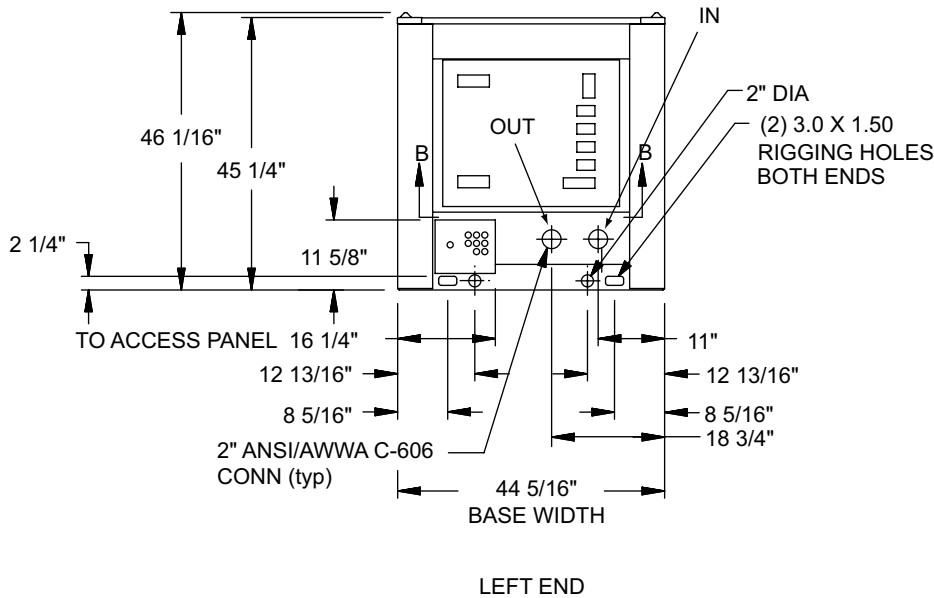
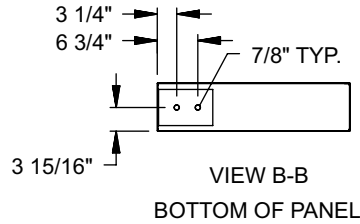

POWER: SINGLE POINT SUPPLY WITH TERMINAL BLOCK

LD18671

NOTE:

Placement on a level surface of free of obstructions (including snow, for winter operation) or air circulation ensures rated performance, reliable operation, and ease of maintenance. Site restrictions may compromise minimum clearances indicated below, resulting in unpredictable airflow patterns and possible diminished performance. The unit controls will optimize operation without nuisance high-pressure safety cut-outs; however, the system designer must consider potential performance degradation. Access to the unit control center assumes the unit is no higher than on spring isolators. Recommended minimum clearances: Side to wall – 6 ft; rear to wall – 6 ft; control panel to end wall – 4 ft; top – no obstructions allowed; distance between adjacent units – 10 ft. No more than one adjacent wall may be higher than the unit.

Unit Dimensions - English (Cont'd)

QTC2020T

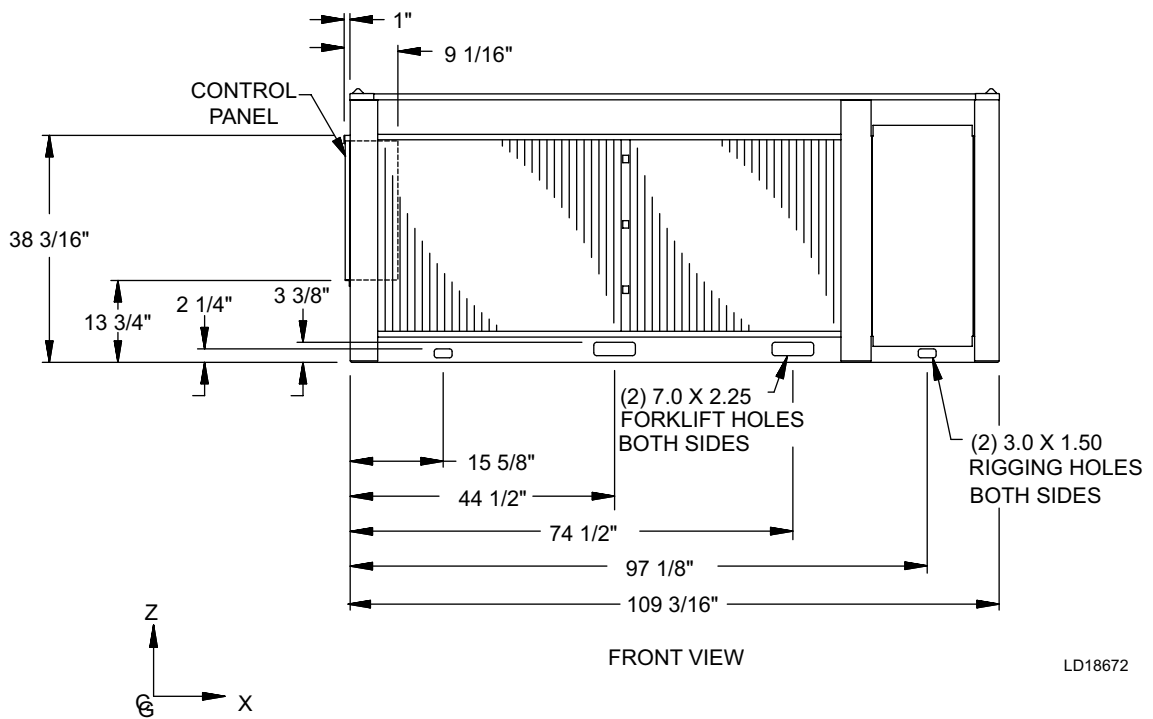
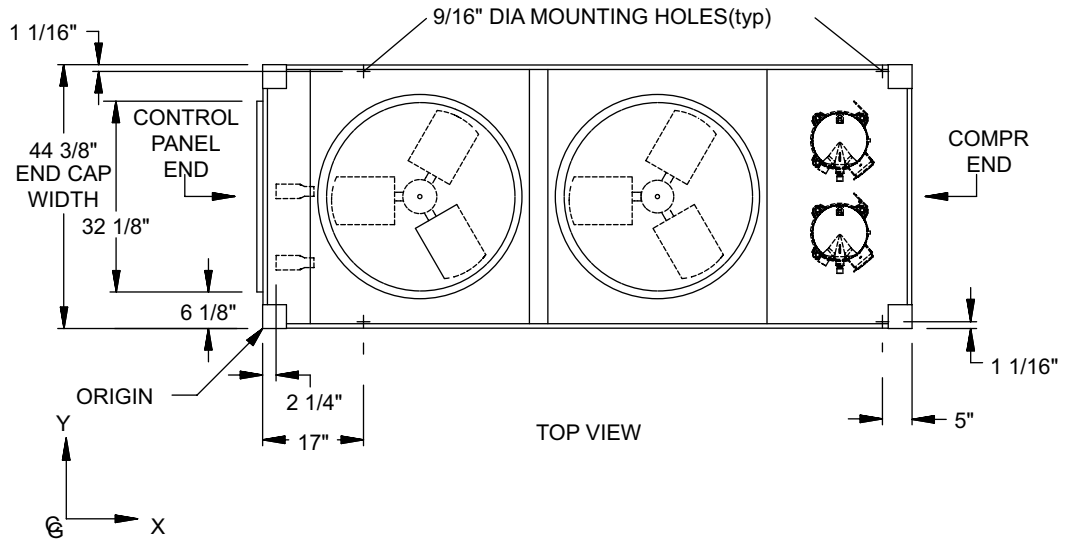

LD18672

Unit Dimensions - English (Cont'd)

QTC2025T

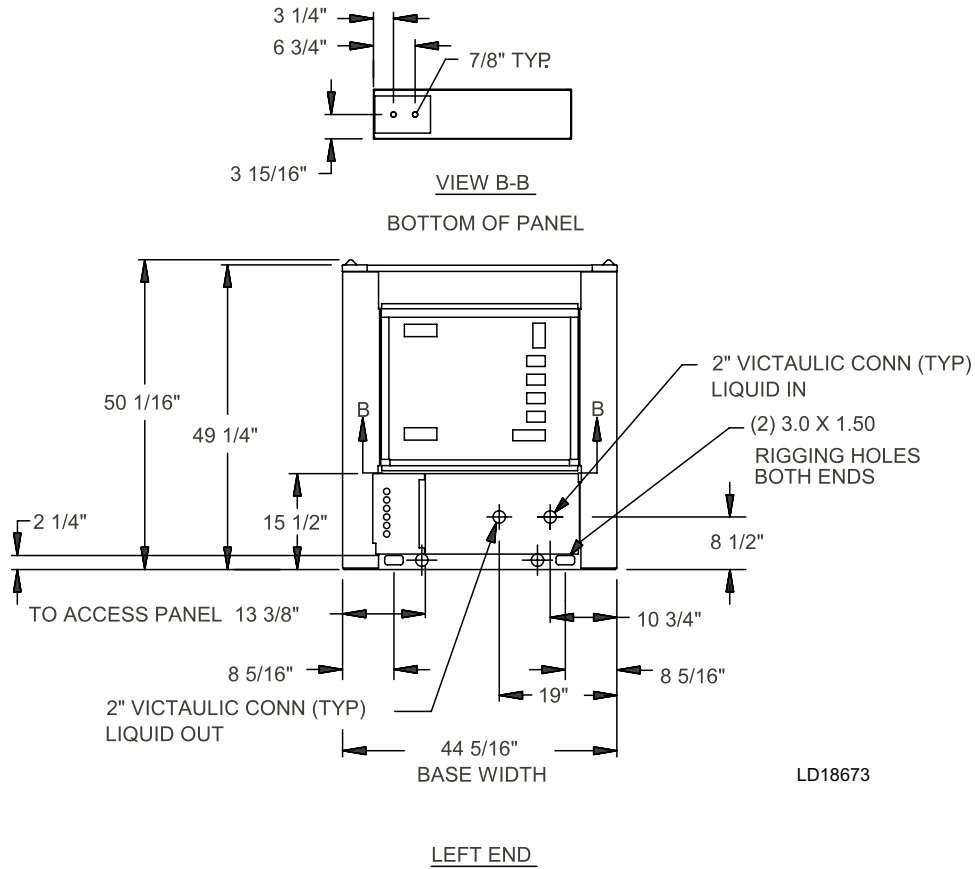

POWER: SINGLE POINT SUPPLY WITH TERMINAL BLOCK

NOTE:

Placement on a level surface of free of obstructions (including snow, for winter operation) or air circulation ensures rated performance, reliable operation, and ease of maintenance. Site restrictions may compromise minimum clearances indicated below, resulting in unpredictable airflow patterns and possible diminished performance. The unit controls will optimize operation without nuisance high-pressure safety cut-outs; however, the system designer must consider potential performance degradation. Access to the unit control center assumes the unit is no higher than on spring isolators. Recommended minimum clearances: Side to wall – 6 ft; rear to wall – 6 ft; control panel to end wall – 4 ft; top – no obstructions allowed; distance between adjacent units – 10 ft. No more than one adjacent wall may be higher than the unit.

Unit Dimensions - English (Cont'd)

QTC2025T

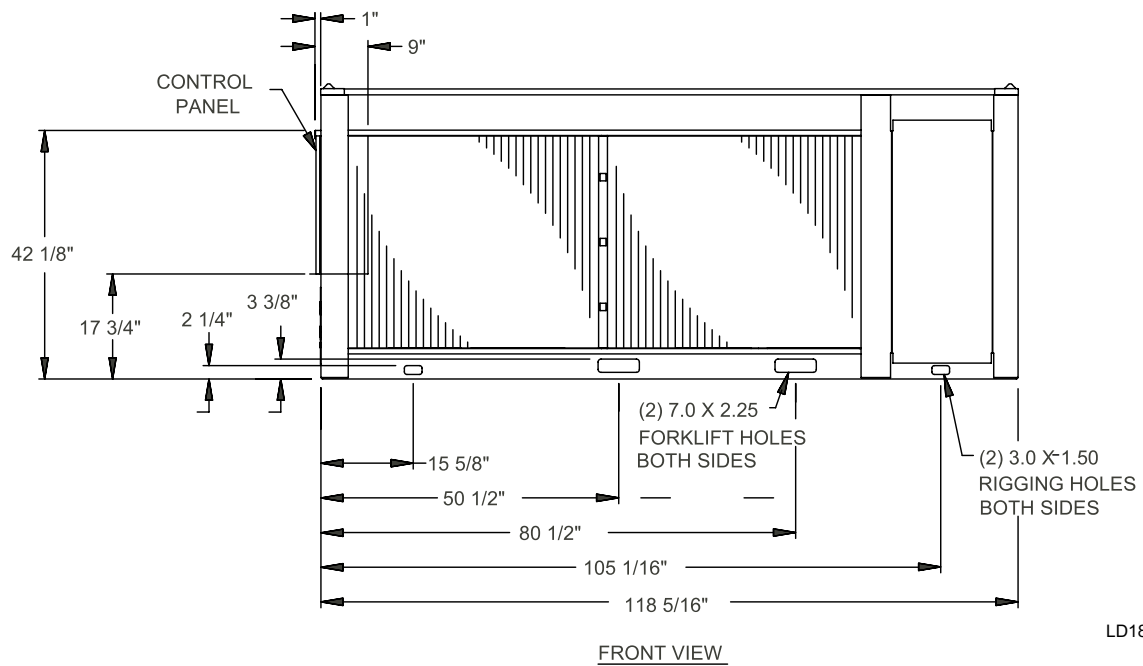
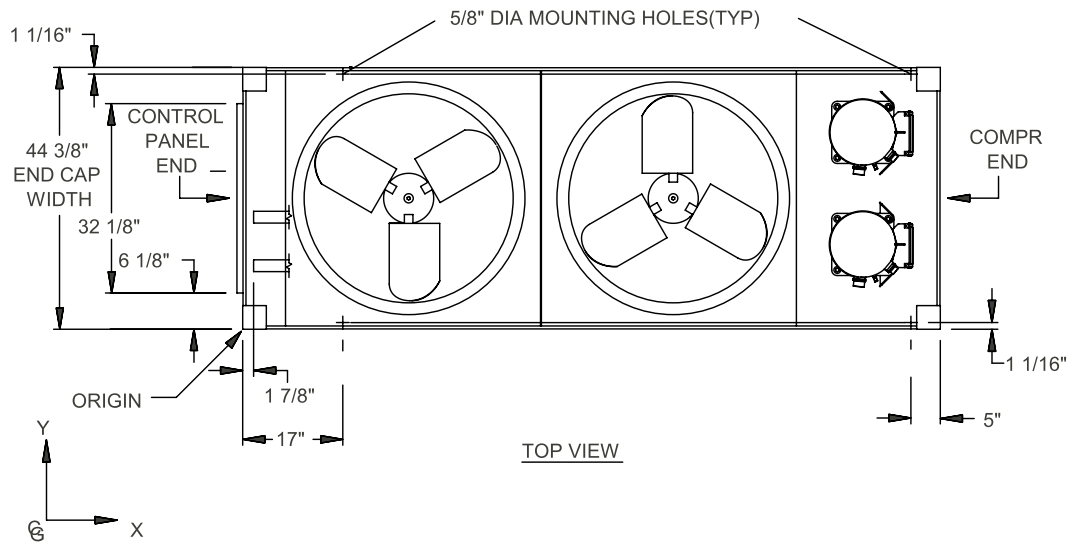

LD18674

Unit Dimensions - English (Cont'd)

QTC2030T

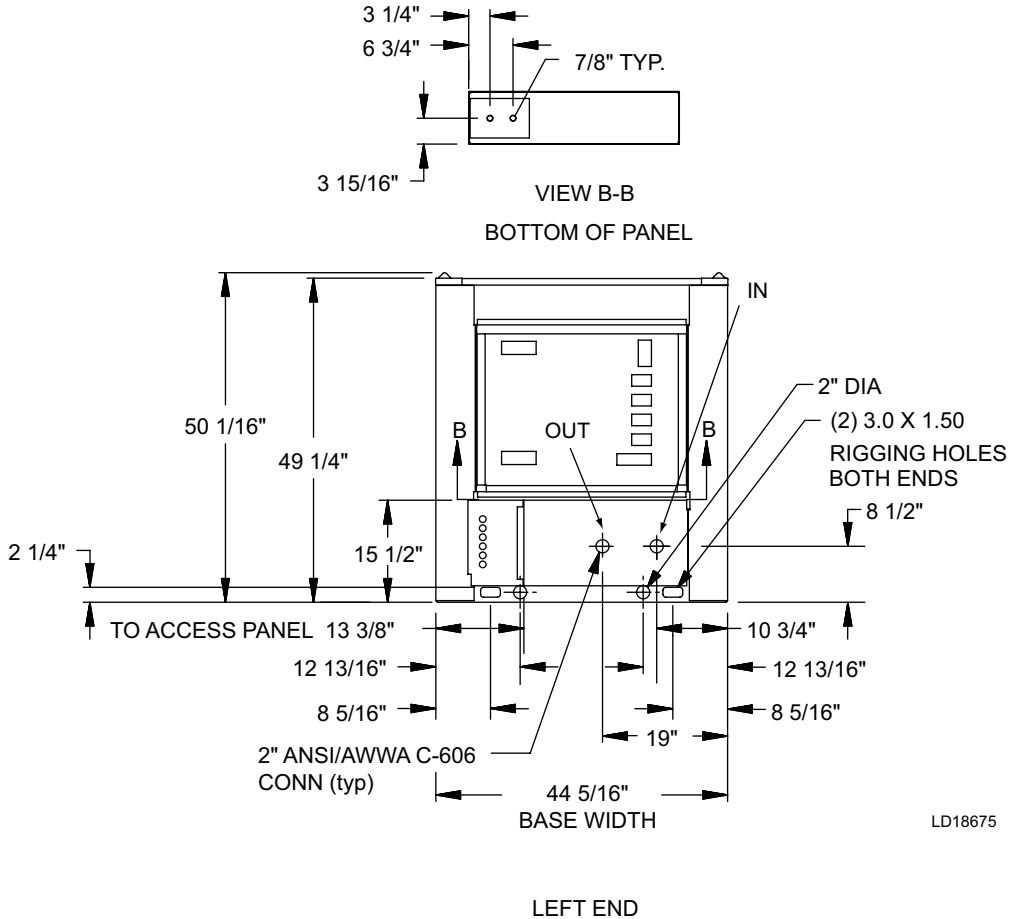

LD18675

POWER: SINGLE POINT SUPPLY WITH TERMINAL BLOCK

NOTE:

Placement on a level surface free of obstructions (including snow, for winter operation) or air circulation ensures rated performance, reliable operation, and ease of maintenance. Site restrictions may compromise minimum clearances indicated below, resulting in unpredictable airflow patterns and possible diminished performance. The unit controls will optimize operation without nuisance high-pressure safety cut-outs; however, the system designer must consider potential performance degradation. Access to the unit control center assumes the unit is no higher than on spring isolators. Recommended minimum clearances: Side to wall - 6 ft; rear to wall - 6 ft; control panel to end wall - 4 ft; top - no obstructions allowed; distance between adjacent units - 10 ft. No more than one adjacent wall may be higher than the unit.

Unit Dimensions - English (Cont'd)

QTC2030T

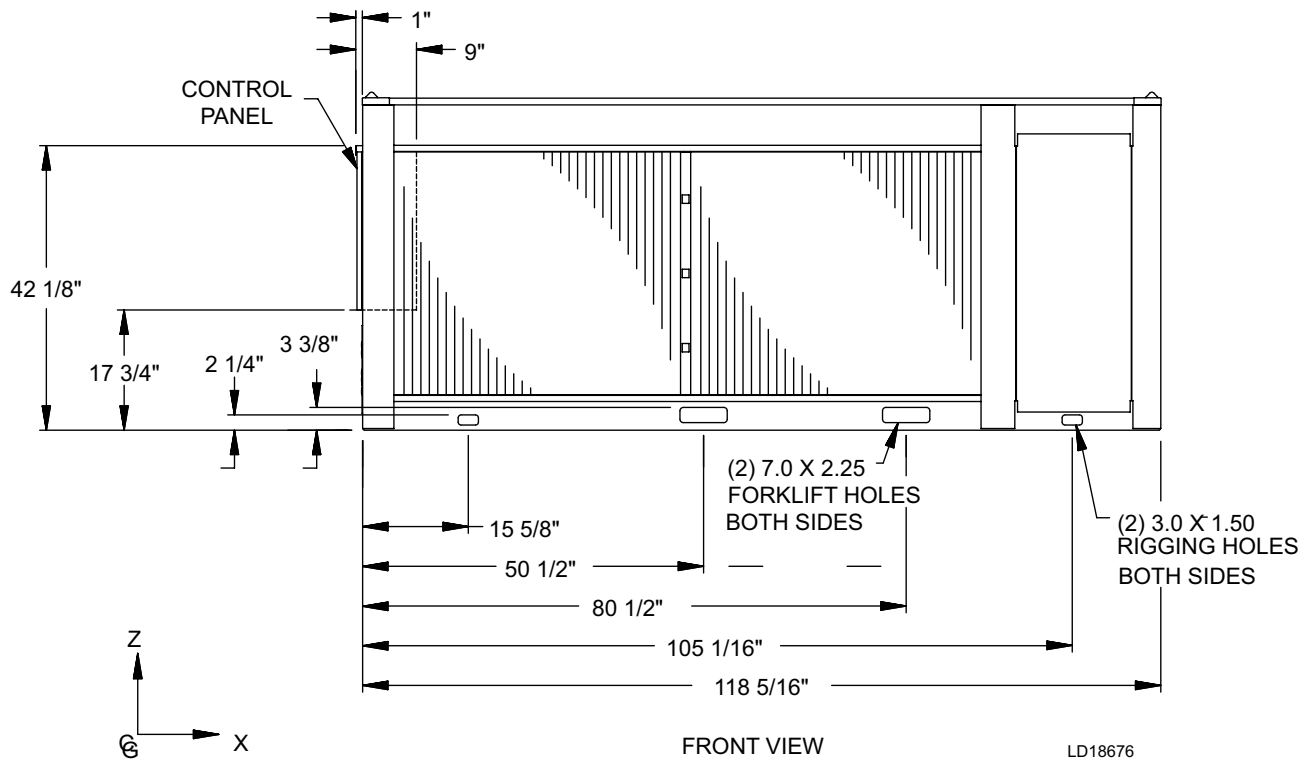
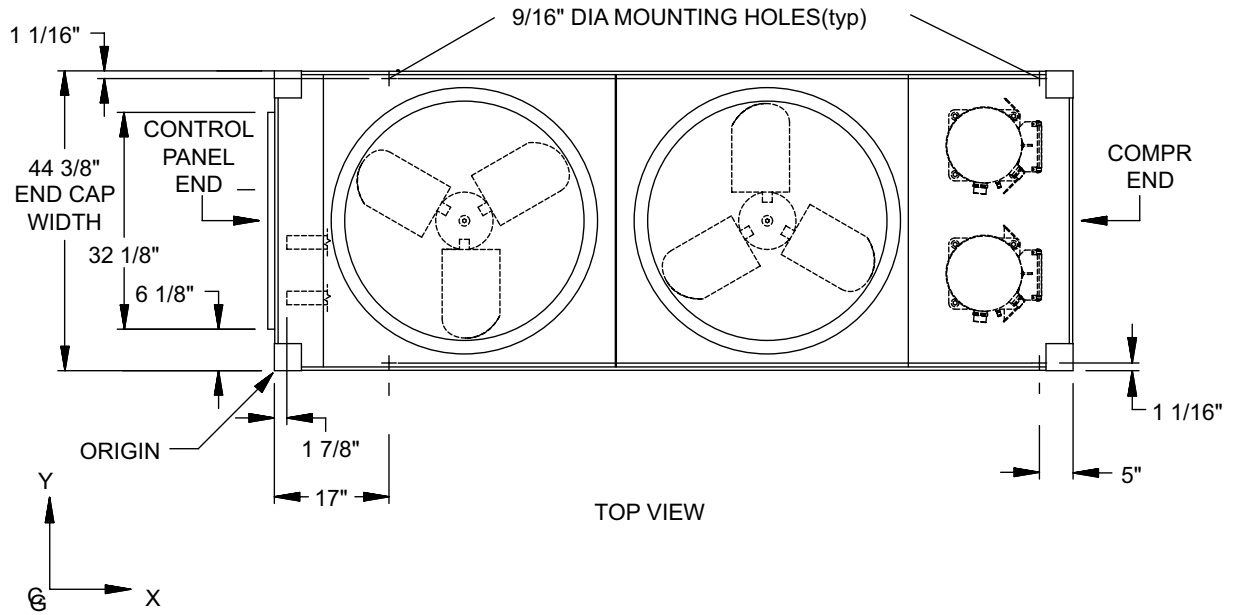

LD18676

Unit Dimensions - English (Cont'd)

QTC2035T

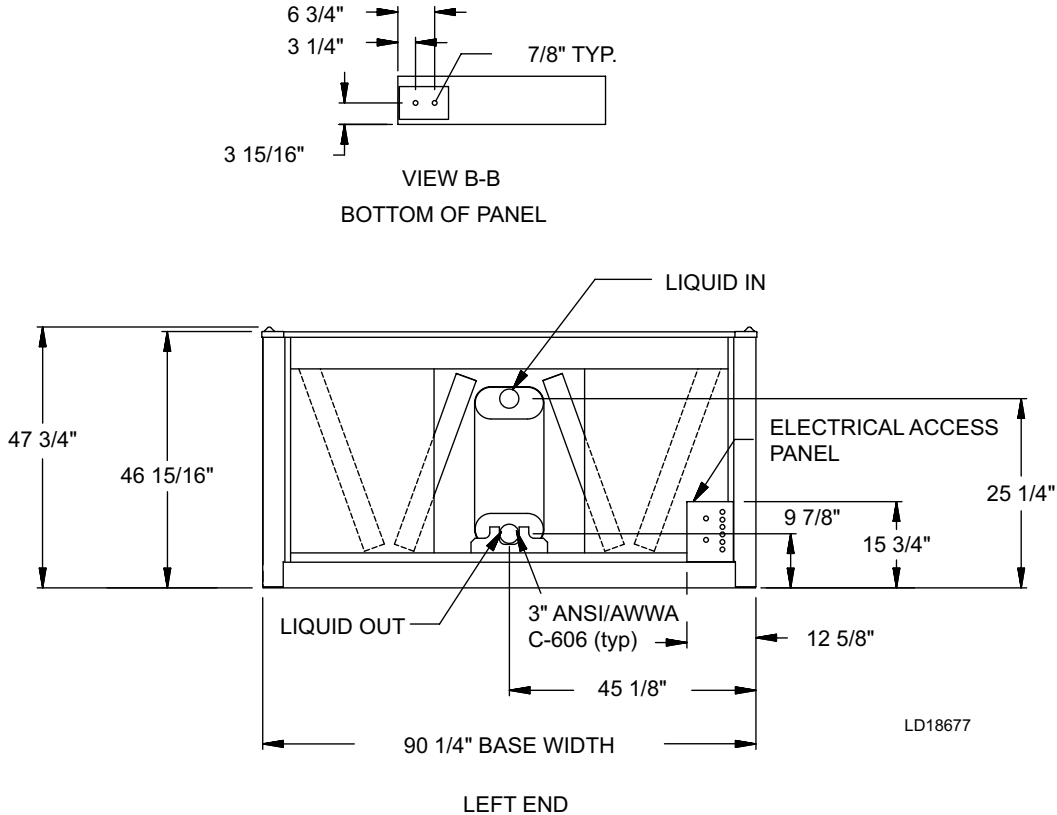

NOTE:

Placement on a level surface of free of obstructions (including snow, for winter operation) or air circulation ensures rated performance, reliable operation, and ease of maintenance. Site restrictions may compromise minimum clearances indicated below, resulting in unpredictable airflow patterns and possible diminished performance. The unit controls will optimize operation without nuisance high-pressure safety cut-outs; however, the system designer must consider potential performance degradation. Access to the unit control center assumes the unit is no higher than on spring isolators. Recommended minimum clearances: Side to wall – 6 ft; rear to wall – 6 ft; control panel to end wall – 4 ft; top – no obstructions allowed; distance between adjacent units – 10 ft. No more than one adjacent wall may be higher than the unit.

Unit Dimensions - English (Cont'd)

QTC2035T

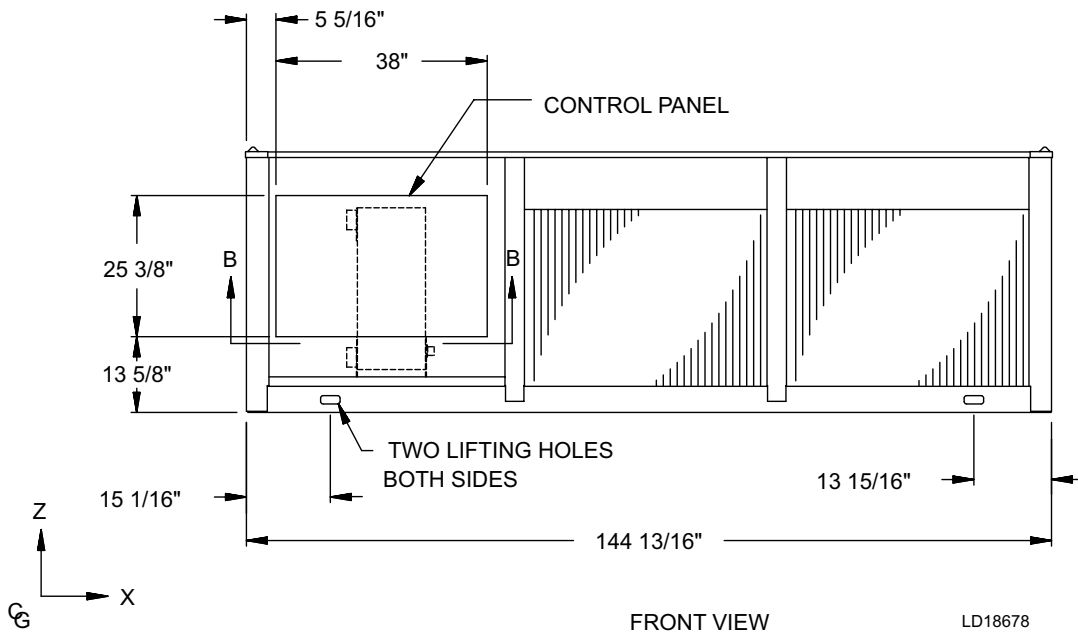
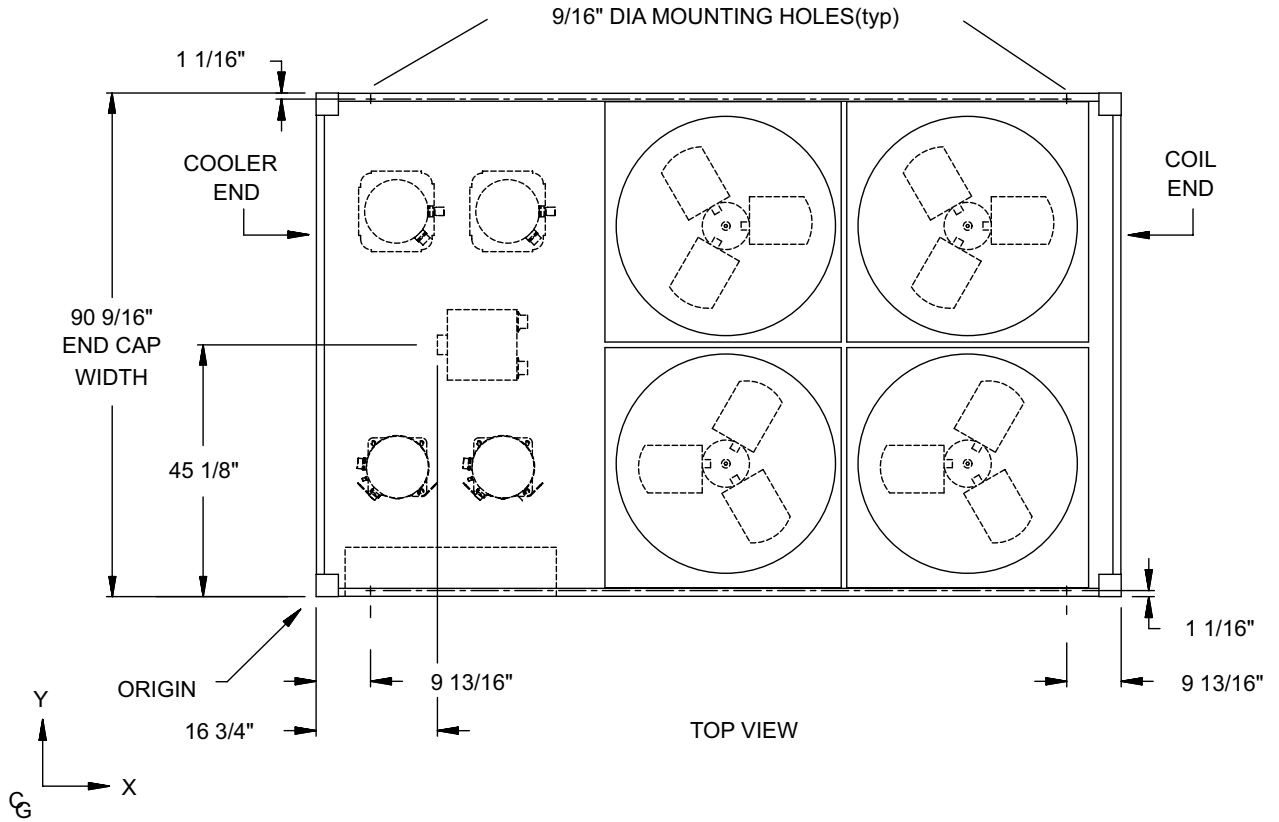

Unit Dimensions - English (Cont'd)

QTC2040T

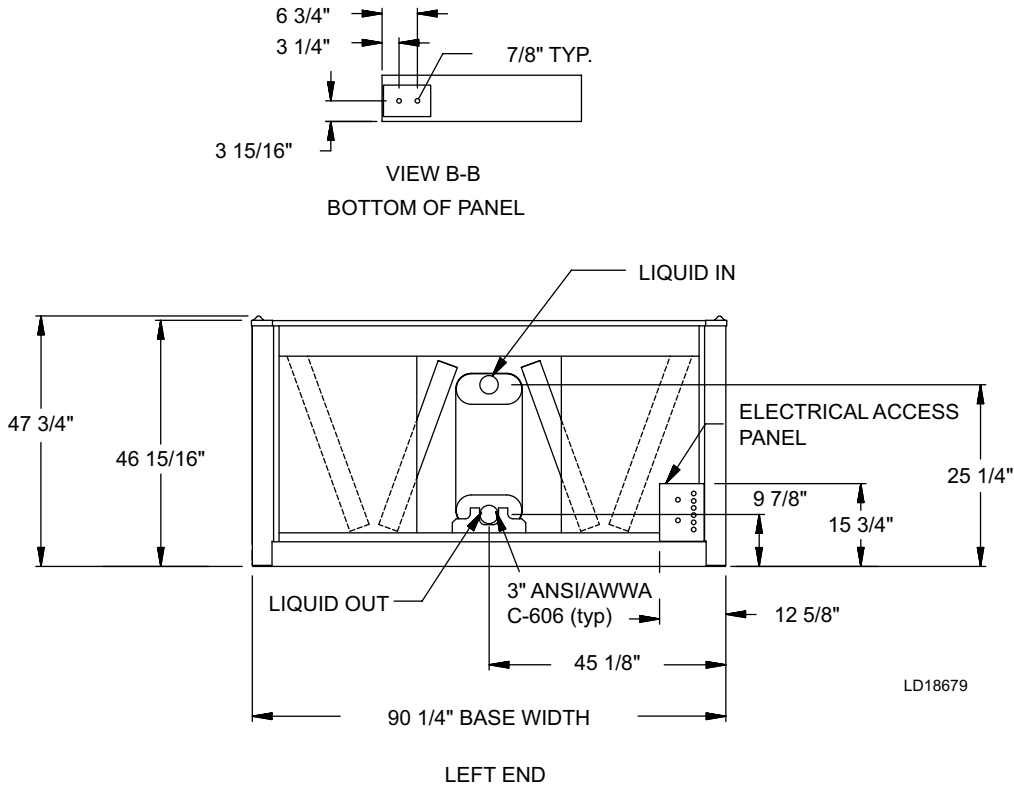

NOTE:

Placement on a level surface of free of obstructions (including snow, for winter operation) or air circulation ensures rated performance, reliable operation, and ease of maintenance. Site restrictions may compromise minimum clearances indicated below, resulting in unpredictable airflow patterns and possible diminished performance. The unit controls will optimize operation without nuisance high-pressure safety cut-outs; however, the system designer must consider potential performance degradation. Access to the unit control center assumes the unit is no higher than on spring isolators. Recommended minimum clearances: Side to wall – 6 ft; rear to wall – 6 ft; control panel to end wall – 4 ft; top – no obstructions allowed; distance between adjacent units – 10 ft. No more than one adjacent wall may be higher than the unit.

Unit Dimensions - English (Cont'd)

QTC2040T

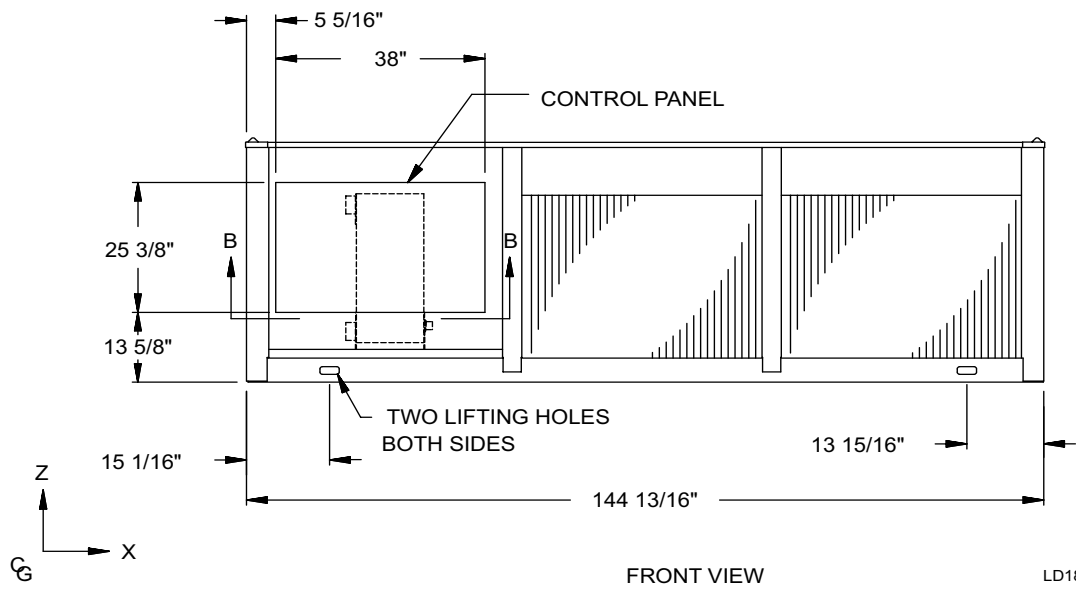
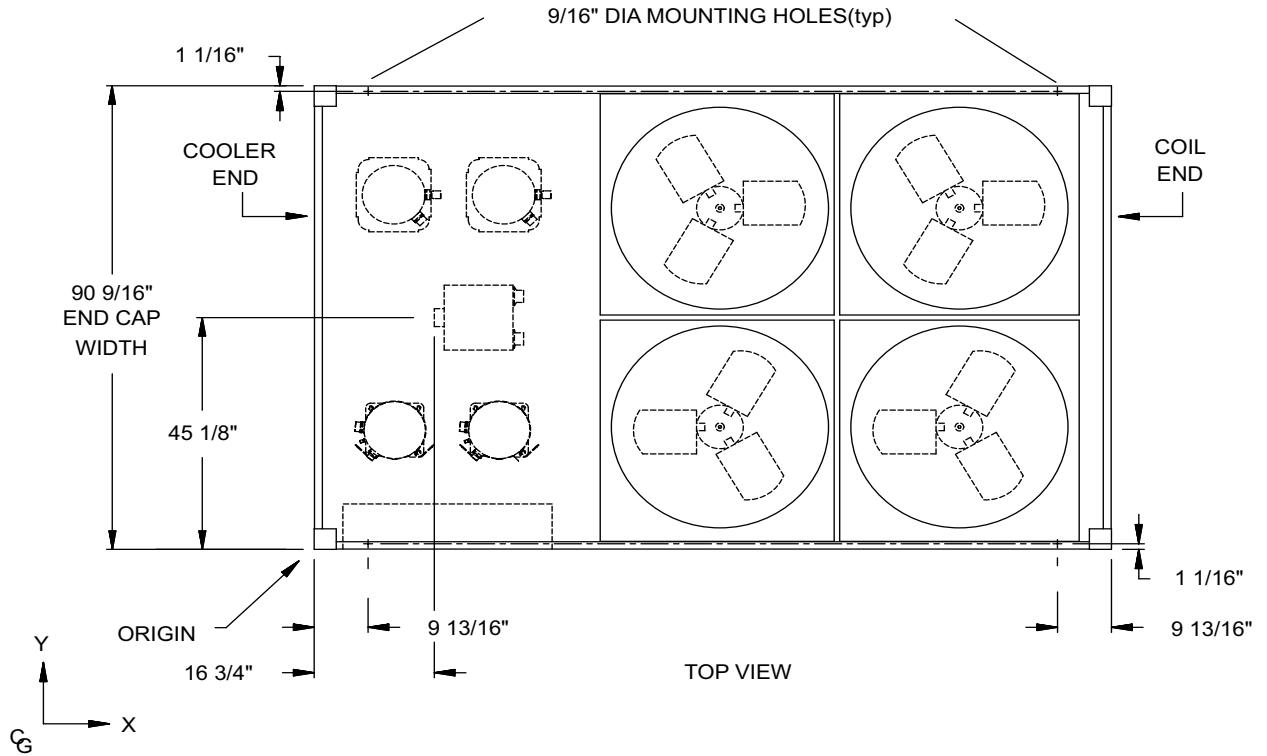

LD18680

Unit Dimensions - English (Cont'd)

QTC2045T

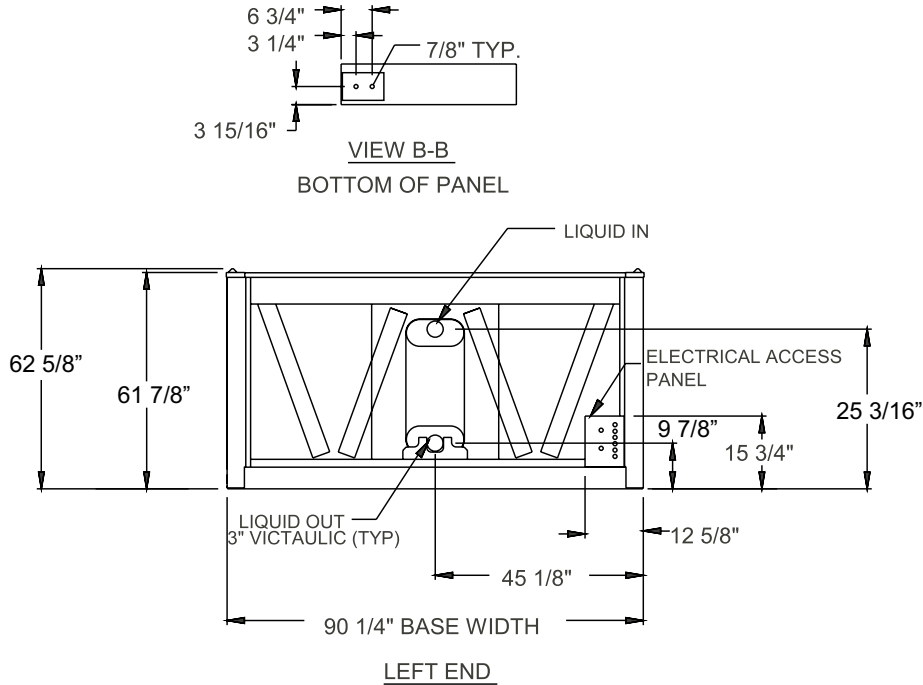

LD18681

POWER: SINGLE POINT SUPPLY WITH TERMINAL BLOCK

NOTE:

Placement on a level surface of free of obstructions (including snow, for winter operation) or air circulation ensures rated performance, reliable operation, and ease of maintenance. Site restrictions may compromise minimum clearances indicated below, resulting in unpredictable airflow patterns and possible diminished performance. The unit controls will optimize operation without nuisance high-pressure safety cut-outs; however, the system designer must consider potential performance degradation. Access to the unit control center assumes the unit is no higher than on spring isolators. Recommended minimum clearances: Side to wall – 6 ft; rear to wall – 6 ft; control panel to end wall – 4 ft; top – no obstructions allowed; distance between adjacent units – 10 ft. No more than one adjacent wall may be higher than the unit.

Unit Dimensions - English (Cont'd)

QTC2045T

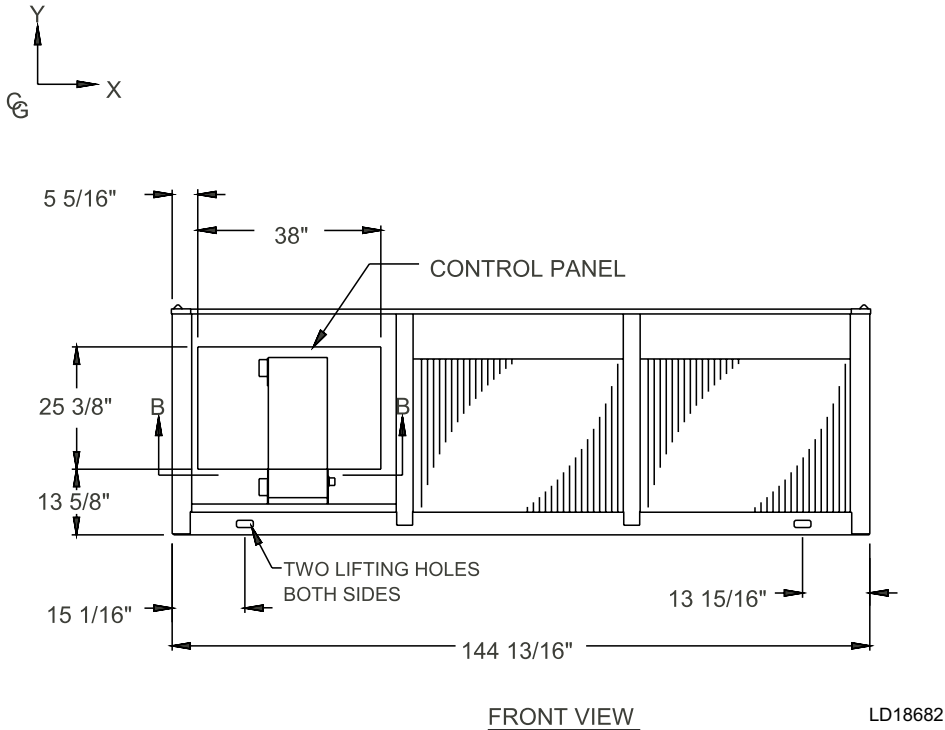
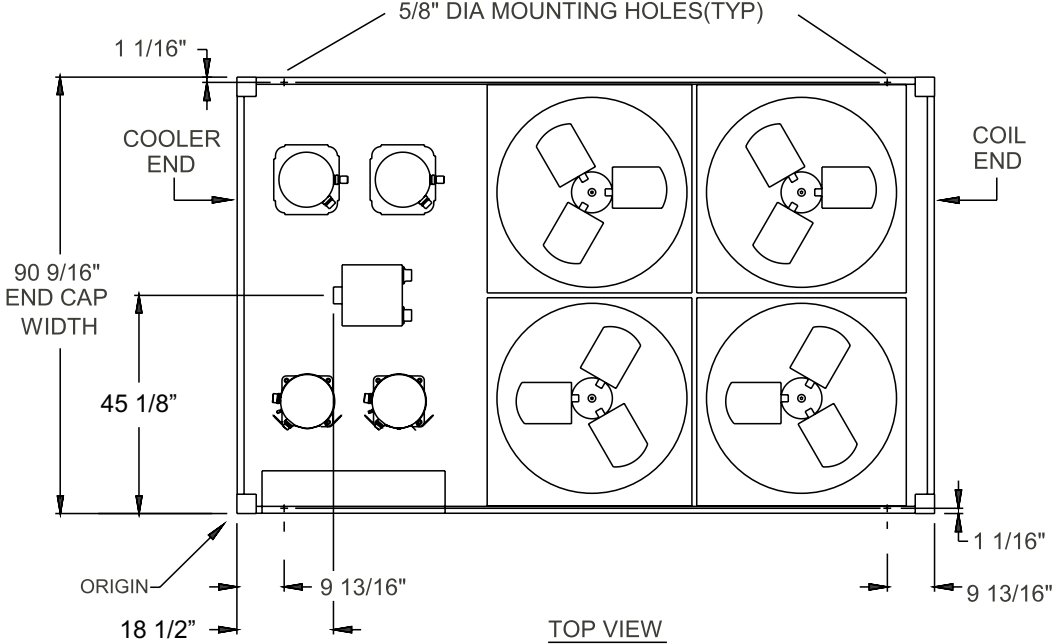

Unit Dimensions - Metric

QTC2015T

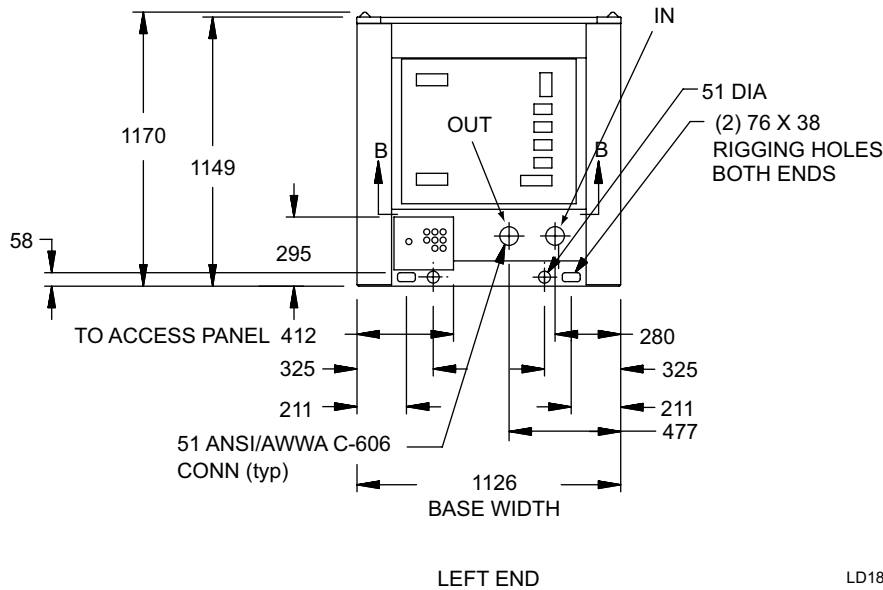
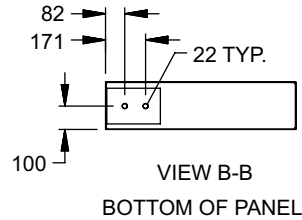

LD18689

NOTE: All dimensions are in mm unless specified otherwise.

NOTE:

Placement on a level surface free of obstructions (including snow, for winter operation) or air circulation ensures rated performance, reliable operation, and ease of maintenance. Site restrictions may compromise minimum clearances indicated below, resulting in unpredictable airflow patterns and possible diminished performance. The unit controls will optimize operation without nuisance high-pressure safety cutouts; however, the system designer must consider potential performance degradation. Recommended minimum clearances: front to wall - 2m; rear to wall - 2m; cooler end to wall - 1.2m; coil end to wall - 2m; top - no obstructions allowed; distance between adjacent units - 3m. No more than one adjacent wall may be higher than the unit. 1" nominal deflection isolators (not shown) will increase overall unit height by 152mm.

Unit Dimensions - Metric (Cont'd)

QTC2015T

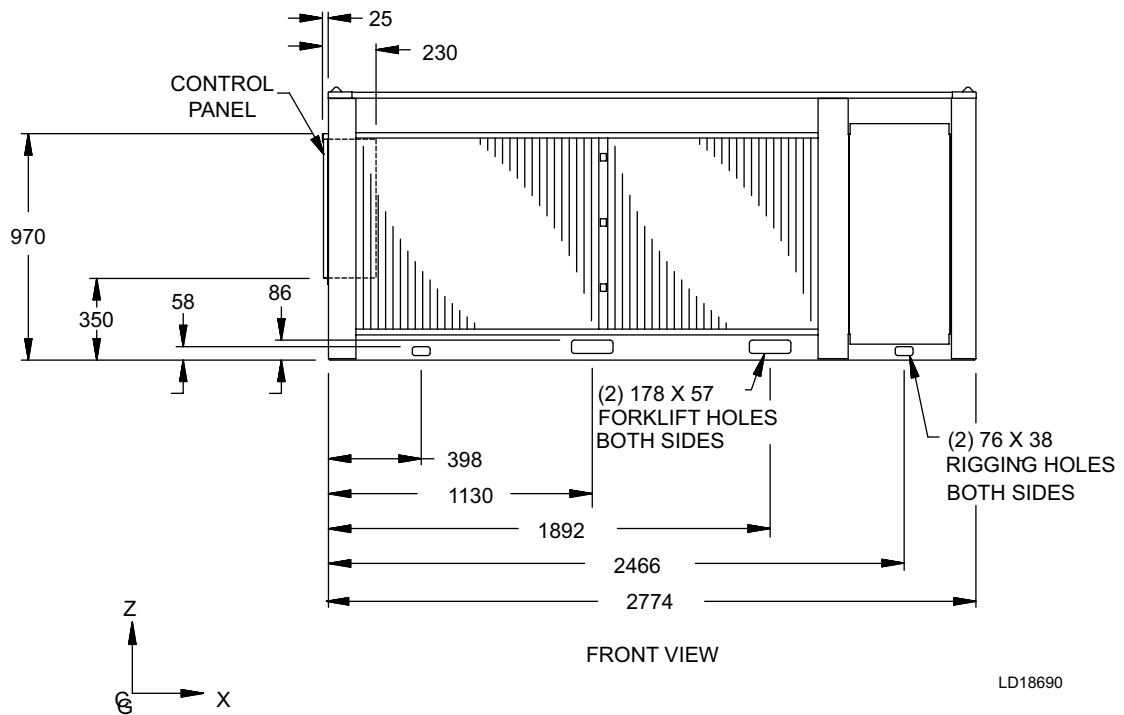
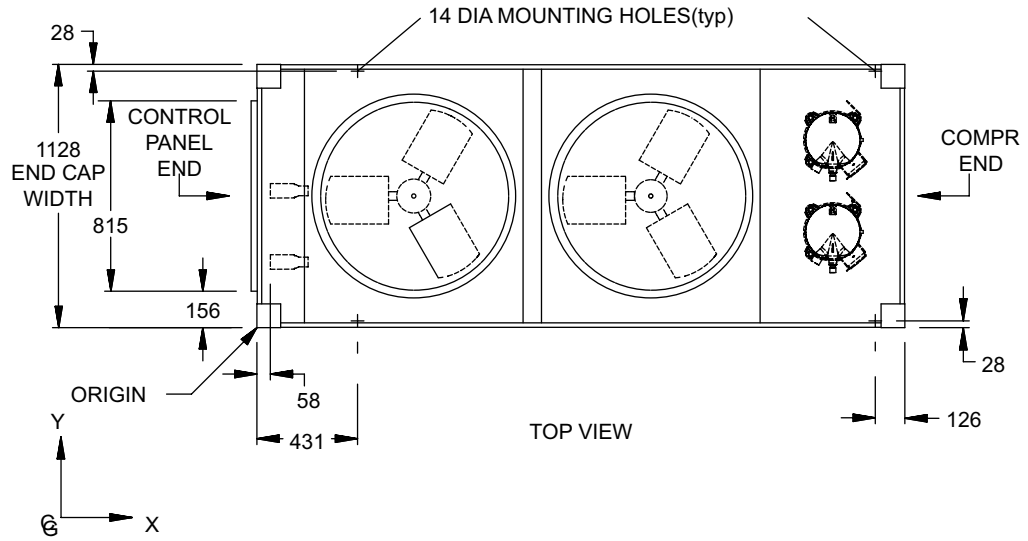

Unit Dimensions - Metric (Cont'd)

QTC2020T

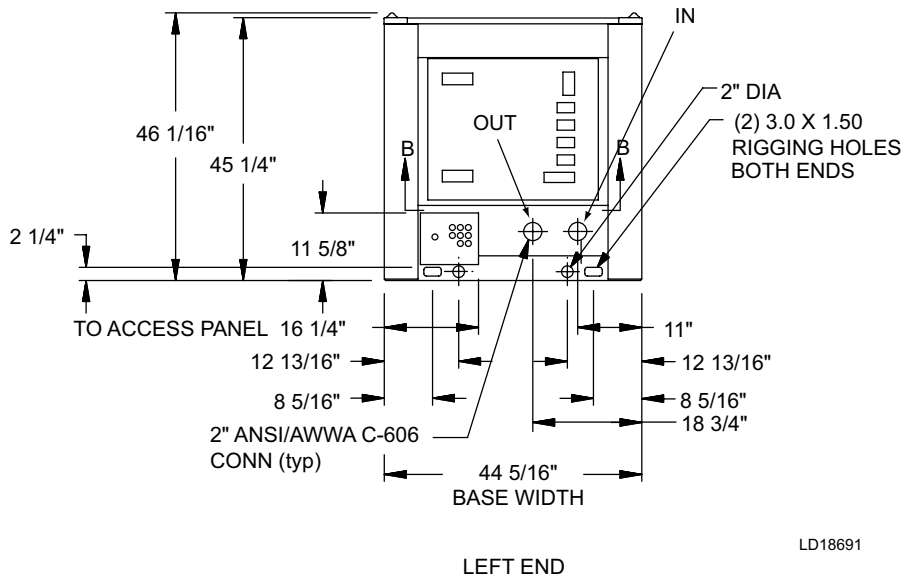
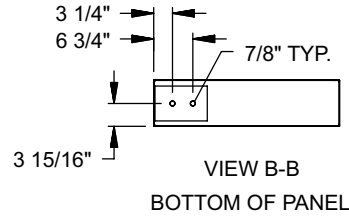

LD18691

POWER: SINGLE POINT SUPPLY WITH TERMINAL BLOCK

NOTE: All dimensions are in mm unless specified otherwise.

NOTE:

Placement on a level surface free of obstructions (including snow, for winter operation) or air circulation ensures rated performance, reliable operation, and ease of maintenance. Site restrictions may compromise minimum clearances indicated below, resulting in unpredictable airflow patterns and possible diminished performance. The unit controls will optimize operation without nuisance high-pressure safety cutouts; however, the system designer must consider potential performance degradation. Recommended minimum clearances: front to wall - 2m; rear to wall - 2m; cooler end to wall - 1.2m; coil end to wall - 2m; top - no obstructions allowed; distance between adjacent units - 3m. No more than one adjacent wall may be higher than the unit. 1" nominal deflection isolators (not shown) will increase overall unit height by 152mm.

Unit Dimensions - Metric (Cont'd)

QTC2020T

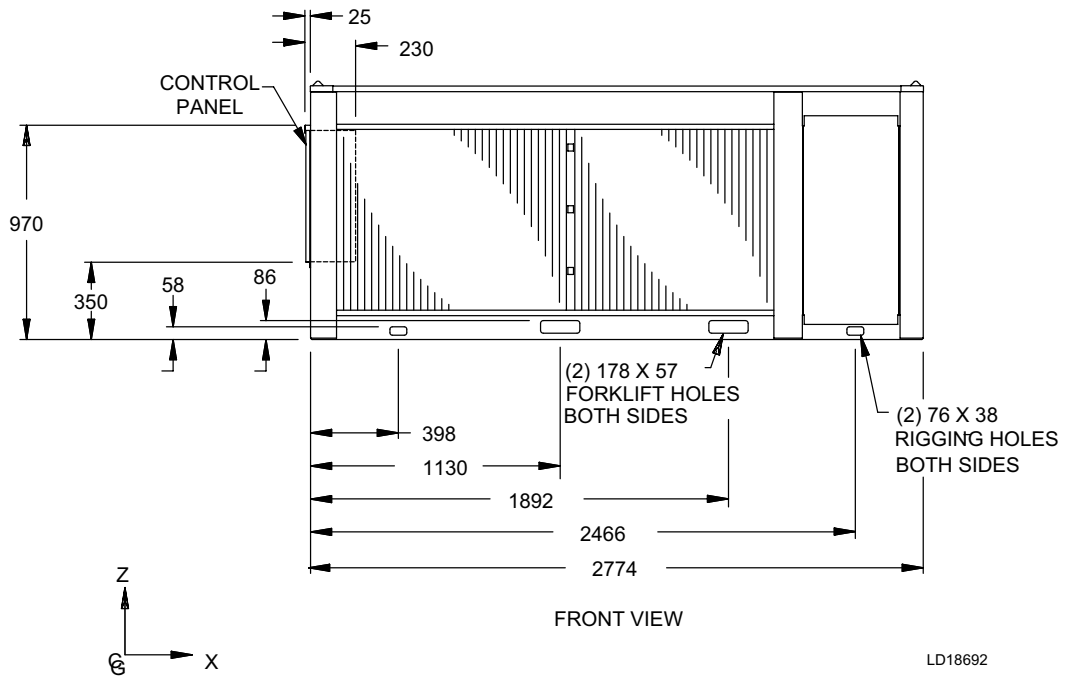
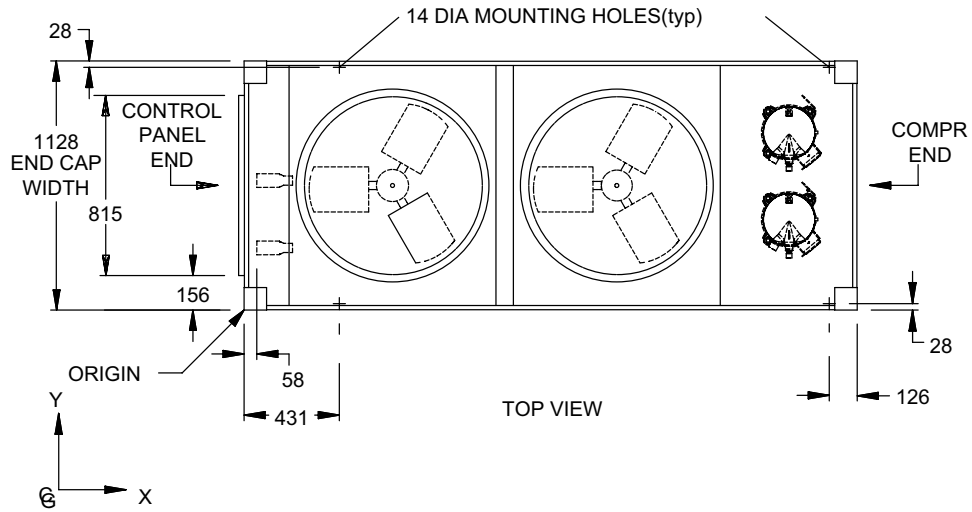

Unit Dimensions - Metric (Cont'd)

QTC2025T

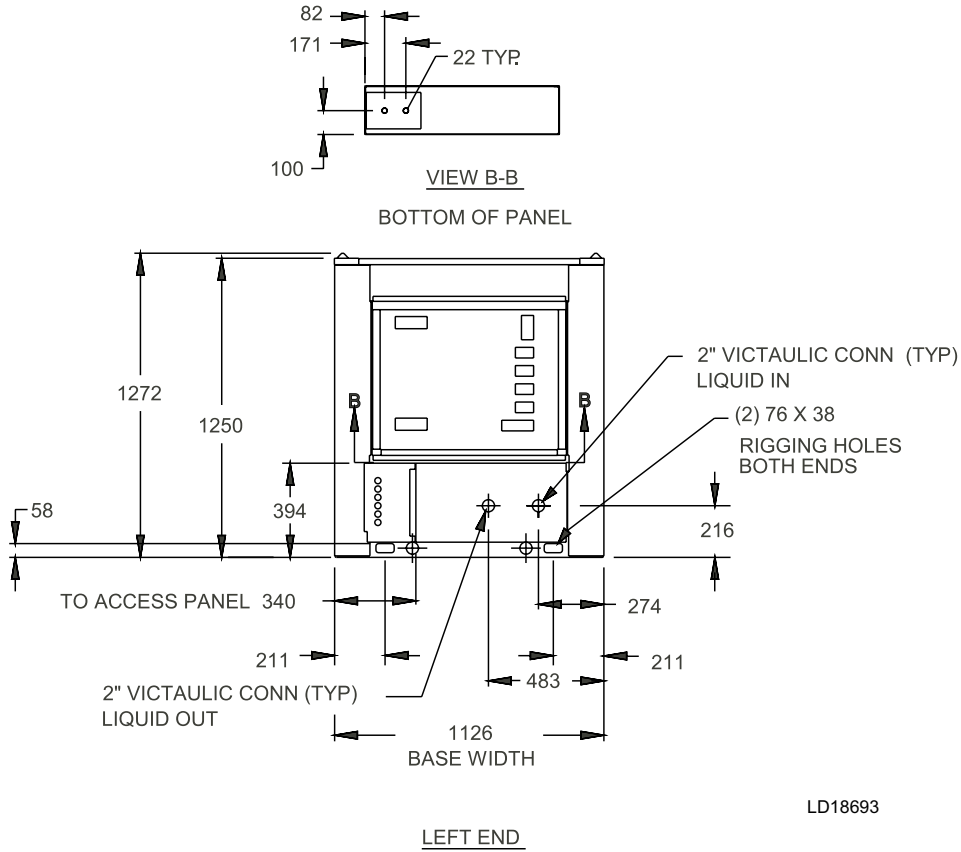

POWER: SINGLE POINT SUPPLY WITH TERMINAL BLOCK

NOTE: All dimensions are in mm unless specified otherwise.

NOTE:

Placement on a level surface free of obstructions (including snow, for winter operation) or air circulation ensures rated performance, reliable operation, and ease of maintenance. Site restrictions may compromise minimum clearances indicated below, resulting in unpredictable airflow patterns and possible diminished performance. The unit controls will optimize operation without nuisance high-pressure safety cutouts; however, the system designer must consider potential performance degradation. Recommended minimum clearances: front to wall - 2m; rear to wall - 2m; cooler end to wall - 1.2m; coil end to wall - 2m; top - no obstructions allowed; distance between adjacent units - 3m. No more than one adjacent wall may be higher than the unit. 1" nominal deflection isolators (not shown) will increase overall unit height by 152mm.

Unit Dimensions - Metric (Cont'd)

QTC2025T

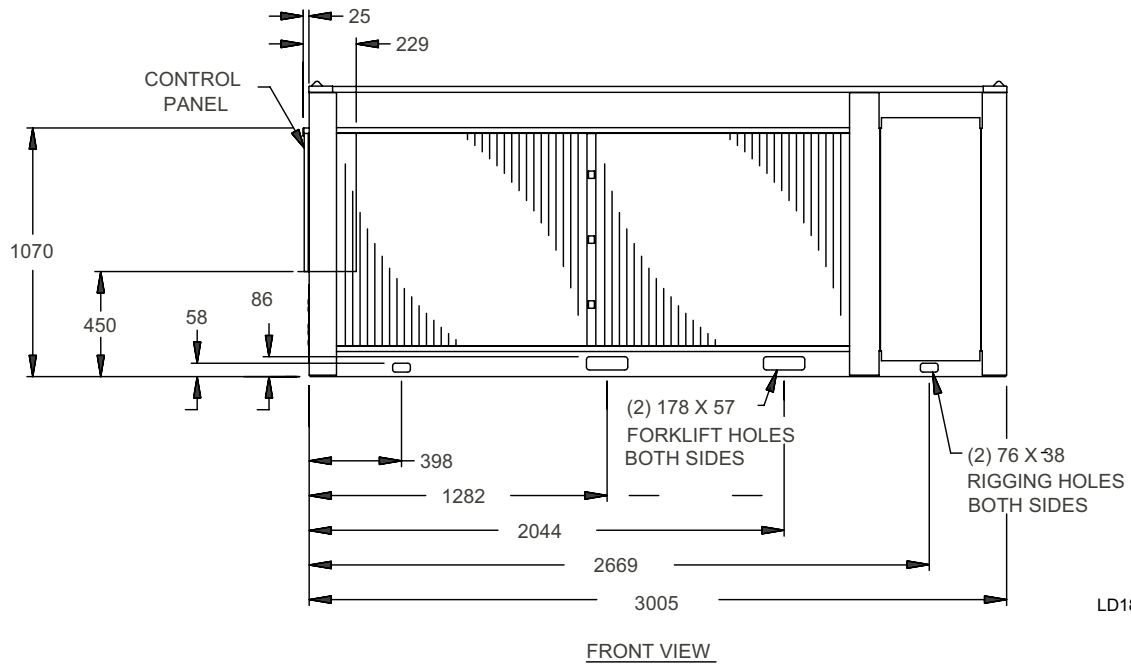
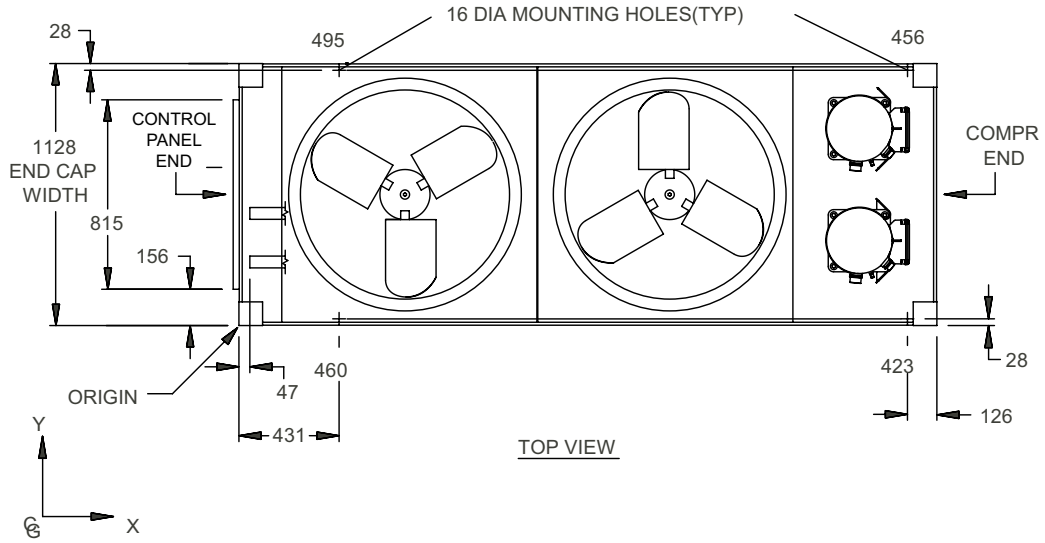

LD18694

Unit Dimensions - Metric (Cont'd)

QTC2030T

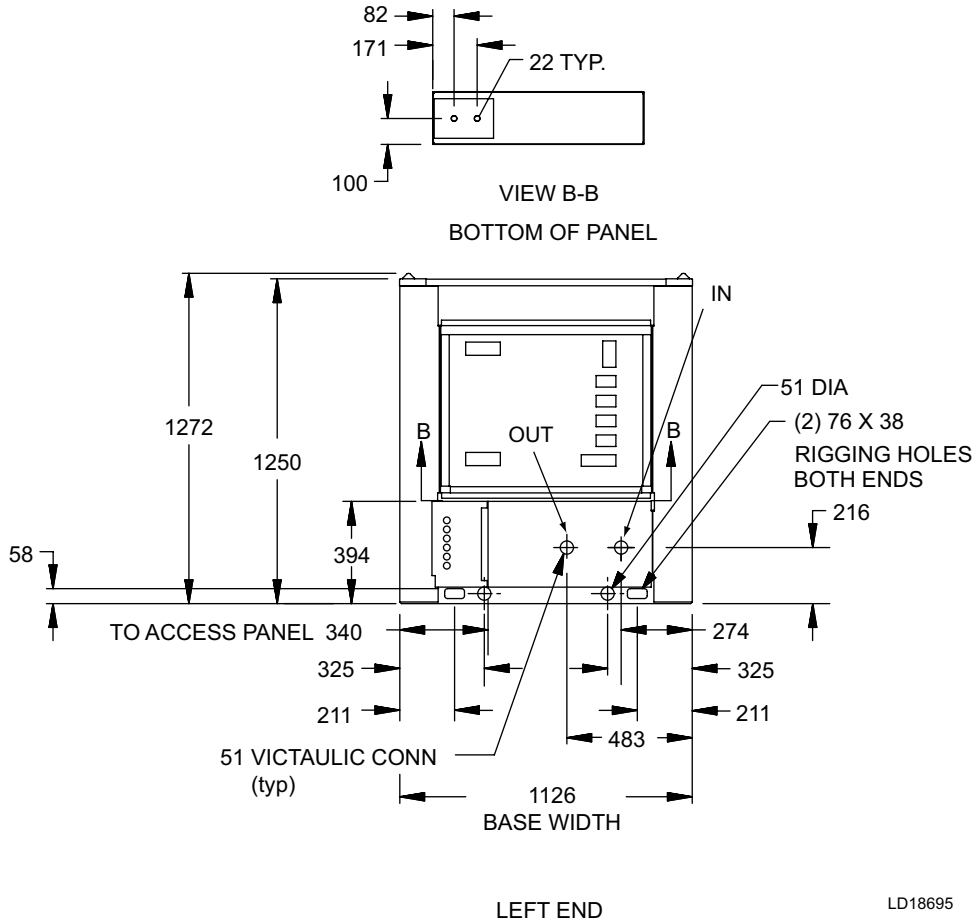

LD18695

POWER: SINGLE POINT SUPPLY WITH TERMINAL BLOCK

NOTE: All dimensions are in mm unless specified otherwise.

NOTE:

Placement on a level surface free of obstructions (including snow, for winter operation) or air circulation ensures rated performance, reliable operation, and ease of maintenance. Site restrictions may compromise minimum clearances indicated below, resulting in unpredictable airflow patterns and possible diminished performance. The unit controls will optimize operation without nuisance high-pressure safety cutouts; however, the system designer must consider potential performance degradation. Recommended minimum clearances: front to wall - 2m; rear to wall - 2m; cooler end to wall - 1.2m; coil end to wall - 2m; top - no obstructions allowed; distance between adjacent units - 3m. No more than one adjacent wall may be higher than the unit. 1" nominal deflection isolators (not shown) will increase overall unit height by 152mm.

Unit Dimensions - Metric (Cont'd)

QTC2030T

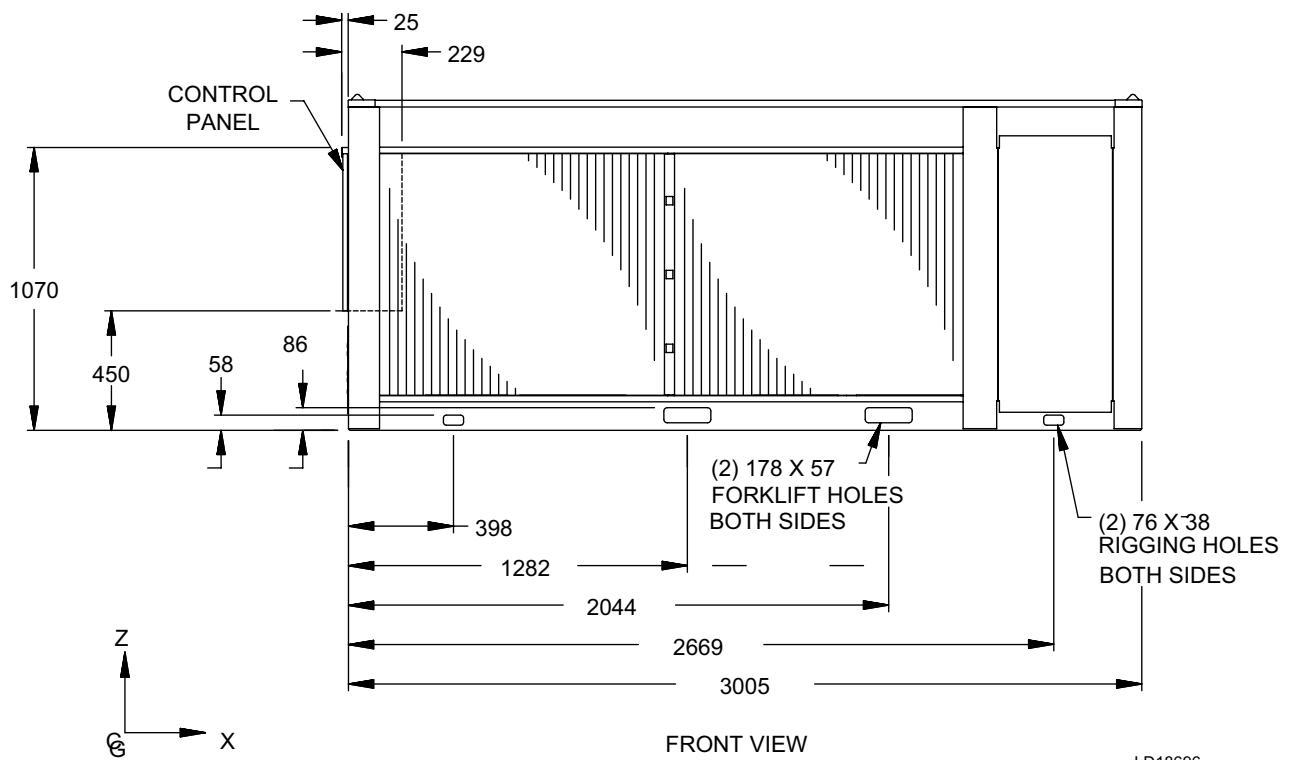
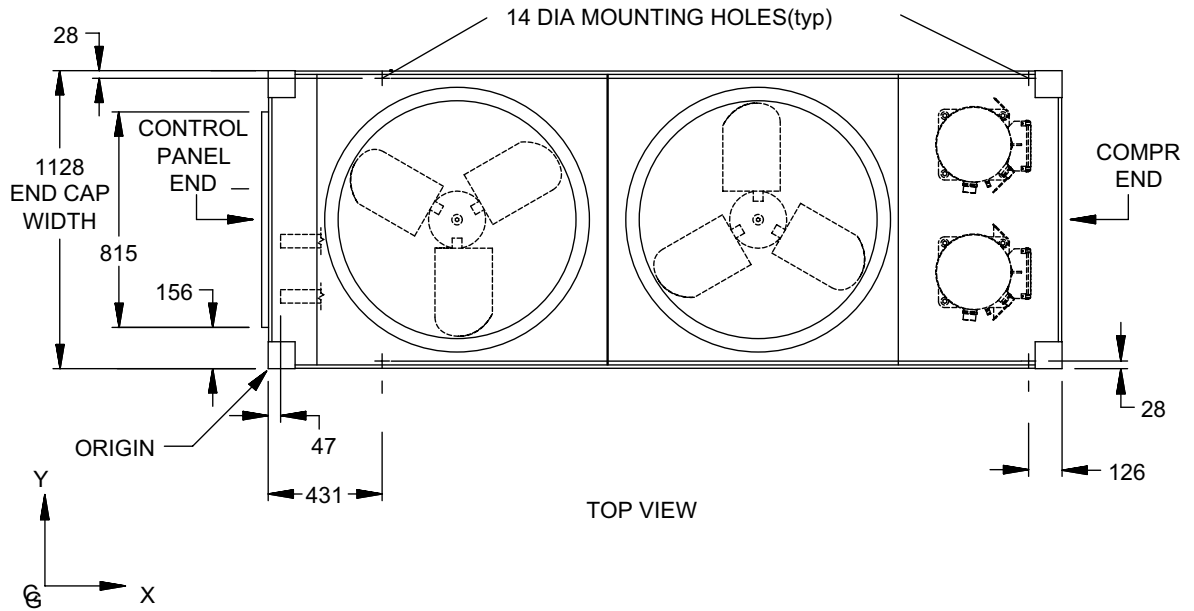

LD18696

Unit Dimensions - Metric (Cont'd)

QTC2035T

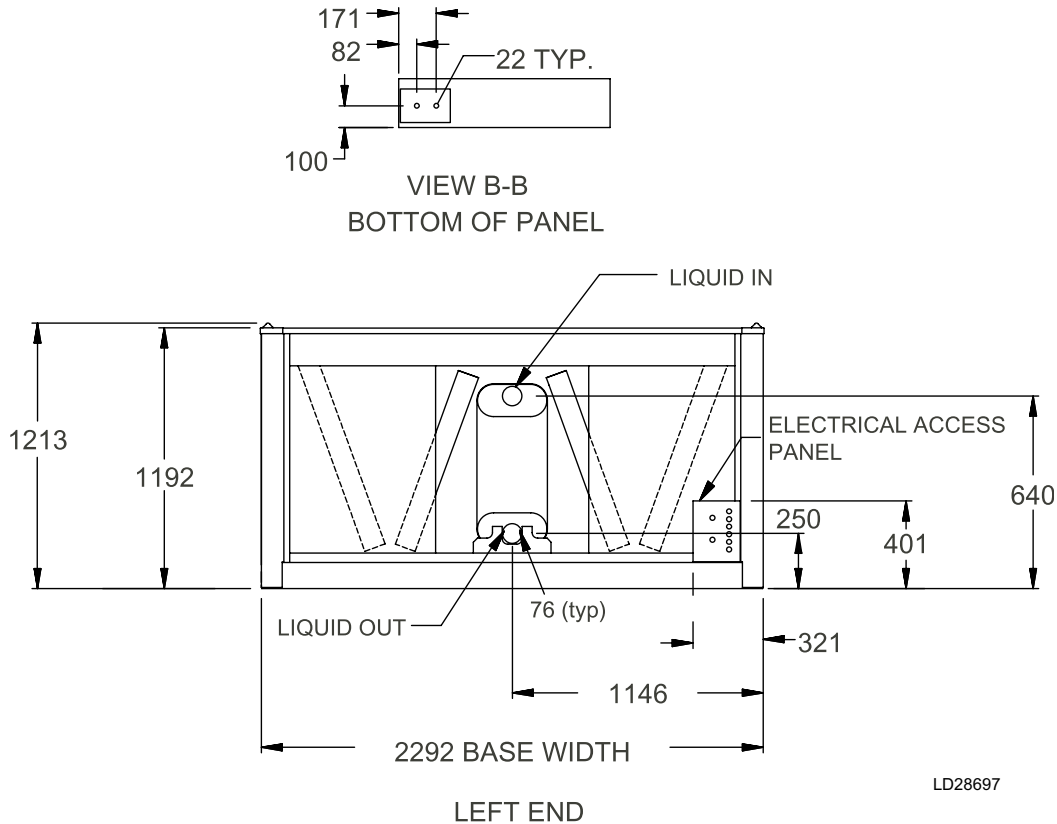

NOTE: All dimensions are in mm unless specified otherwise.

NOTE:

Placement on a level surface free of obstructions (including snow, for winter operation) or air circulation ensures rated performance, reliable operation, and ease of maintenance. Site restrictions may compromise minimum clearances indicated below, resulting in unpredictable airflow patterns and possible diminished performance. The unit controls will optimize operation without nuisance high-pressure safety cutouts; however, the system designer must consider potential performance degradation. Recommended minimum clearances: front to wall - 2m; rear to wall - 2m; cooler end to wall - 1.2m; coil end to wall - 2m; top - no obstructions allowed; distance between adjacent units - 3m. No more than one adjacent wall may be higher than the unit. 1" nominal deflection isolators (not shown) will increase overall unit height by 152mm.

Unit Dimensions - Metric (Cont'd)

QTC2035T

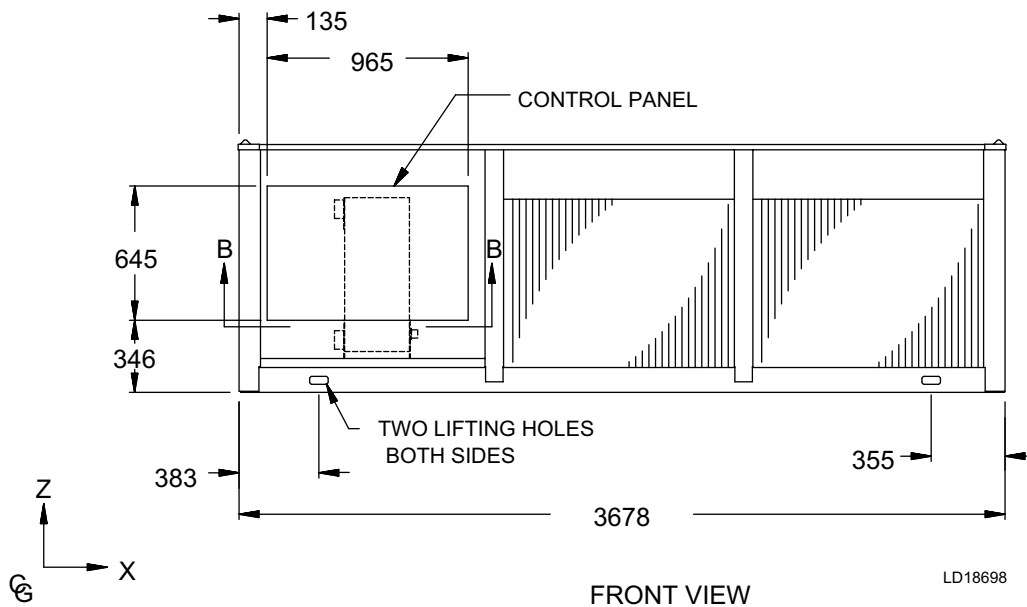
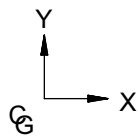
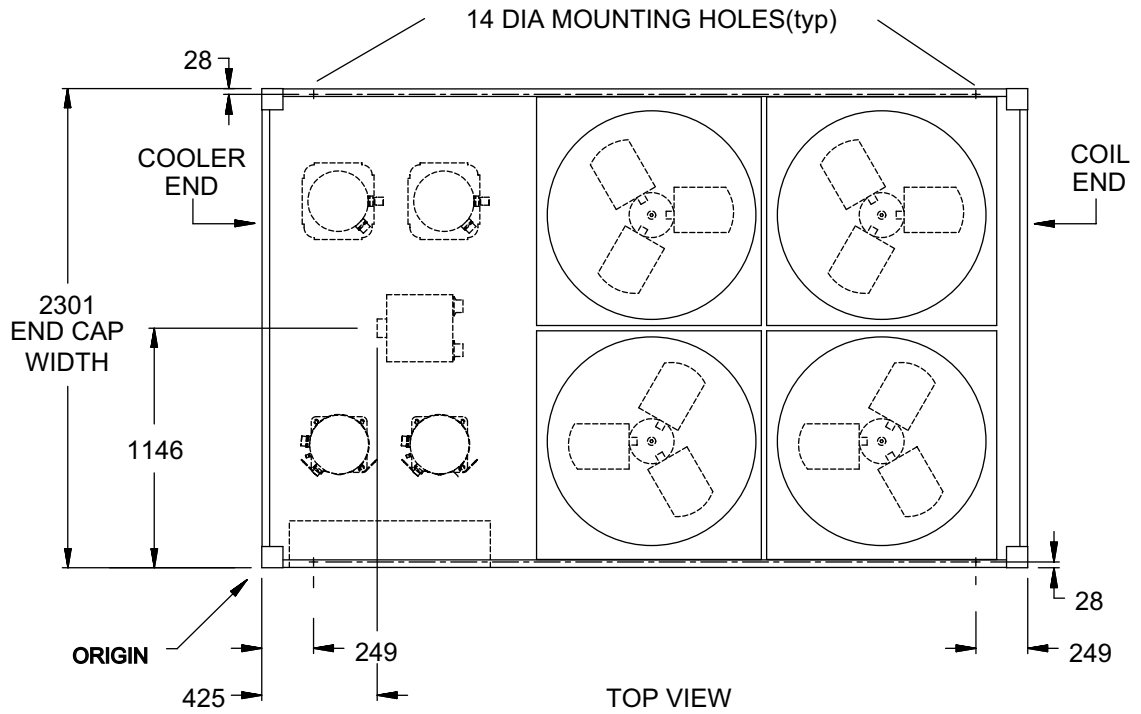

Unit Dimensions - Metric (Cont'd)

QTC2040T

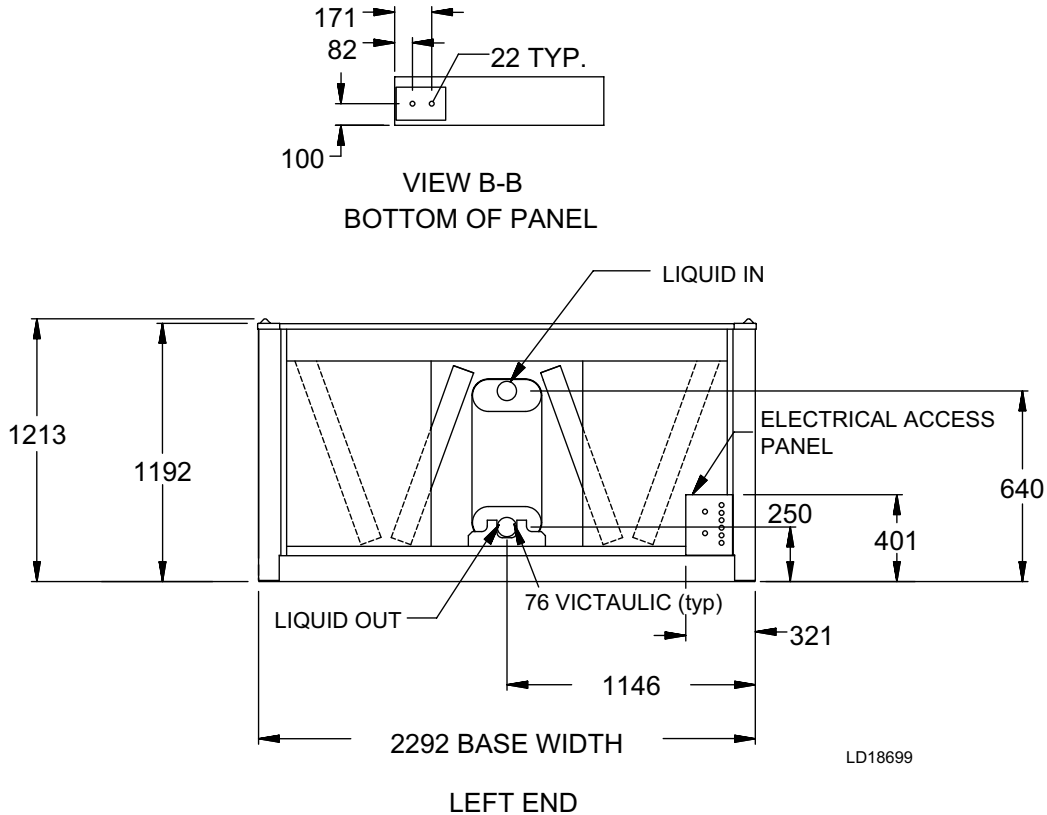

NOTE: All dimensions are in mm unless specified otherwise.

NOTE:

Placement on a level surface free of obstructions (including snow, for winter operation) or air circulation ensures rated performance, reliable operation, and ease of maintenance. Site restrictions may compromise minimum clearances indicated below, resulting in unpredictable airflow patterns and possible diminished performance. The unit controls will optimize operation without nuisance high-pressure safety cutouts; however, the system designer must consider potential performance degradation. Recommended minimum clearances: front to wall - 2m; rear to wall - 2m; cooler end to wall - 1.2m; coil end to wall - 2m; top - no obstructions allowed; distance between adjacent units - 3m. No more than one adjacent wall may be higher than the unit. 1" nominal deflection isolators (not shown) will increase overall unit height by 152mm.

Unit Dimensions - Metric (Cont'd)

QTC2040T

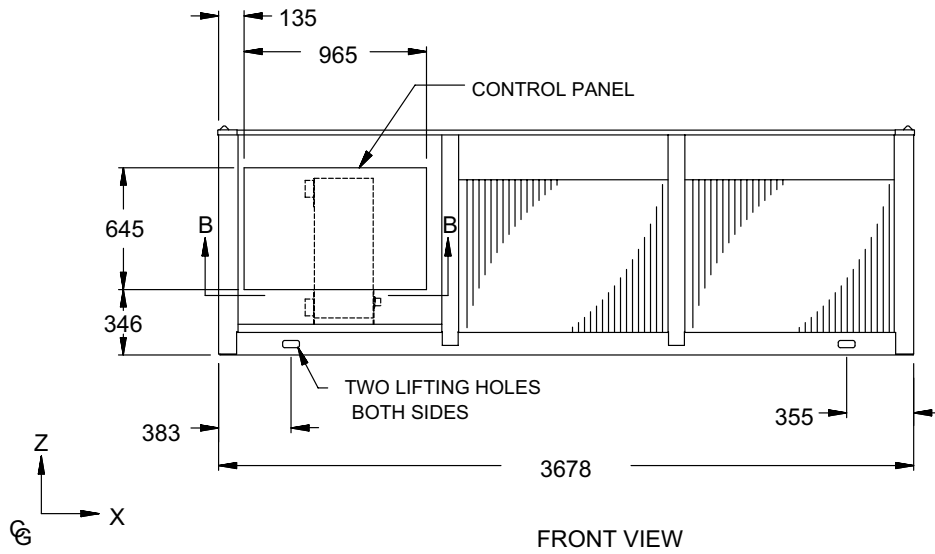
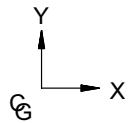
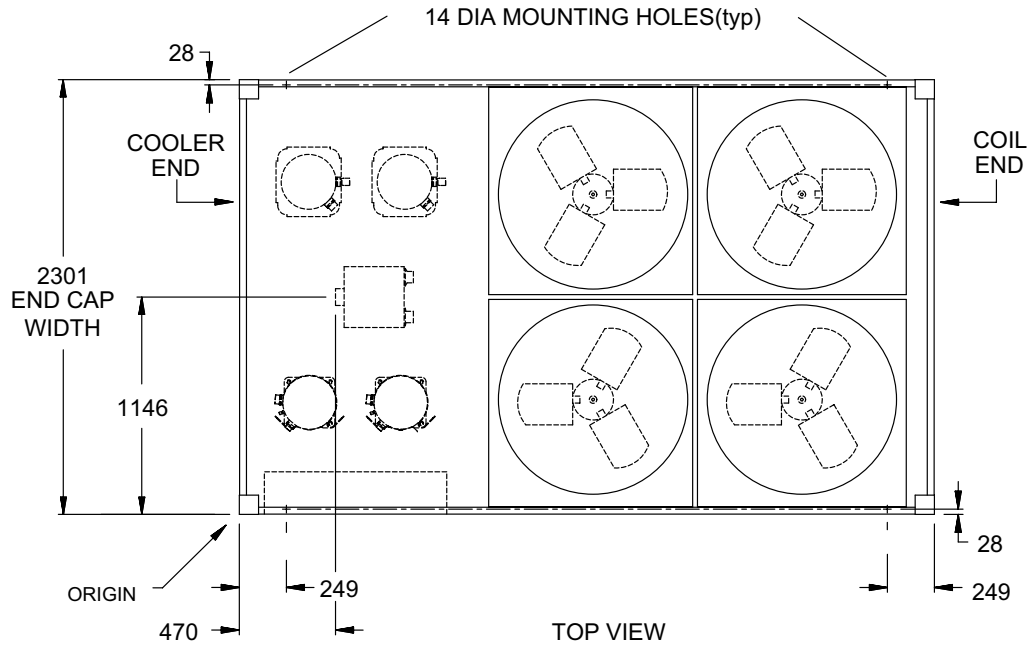

Unit Dimensions - Metric (Cont'd)

QTC2045T

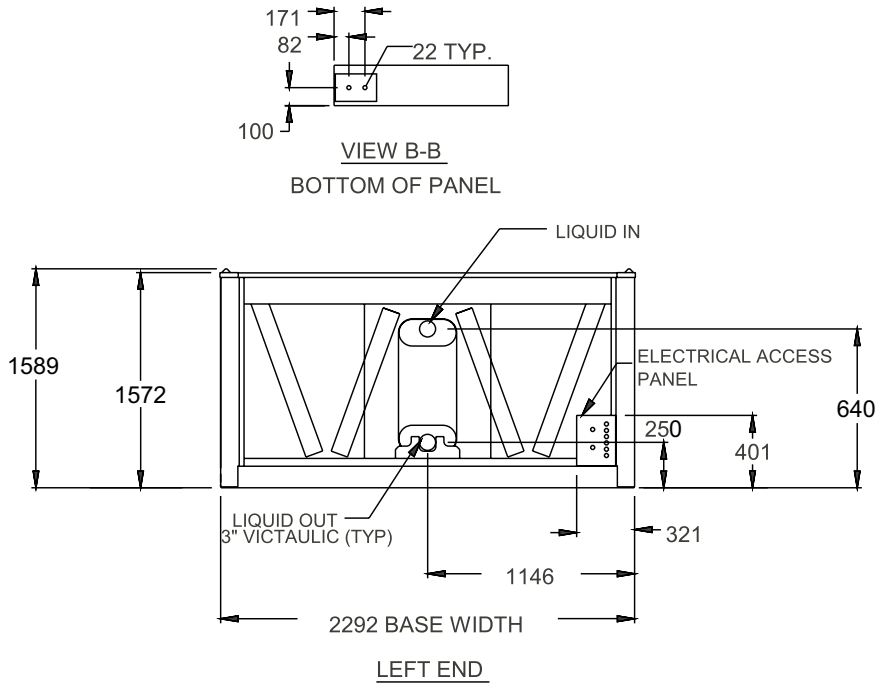

LD18701

POWER: SINGLE POINT SUPPLY WITH TERMINAL BLOCK

NOTE: All dimensions are in mm unless specified otherwise.

NOTE:

Placement on a level surface free of obstructions (including snow, for winter operation) or air circulation ensures rated performance, reliable operation, and ease of maintenance. Site restrictions may compromise minimum clearances indicated below, resulting in unpredictable airflow patterns and possible diminished performance. The unit controls will optimize operation without nuisance high-pressure safety cutouts; however, the system designer must consider potential performance degradation. Recommended minimum clearances: front to wall - 2m; rear to wall - 2m; cooler end to wall - 1.2m; coil end to wall - 2m; top - no obstructions allowed; distance between adjacent units - 3m. No more than one adjacent wall may be higher than the unit. 1" nominal deflection isolators (not shown) will increase overall unit height by 152mm.

Unit Dimensions - Metric (Cont'd)

QTC2045T

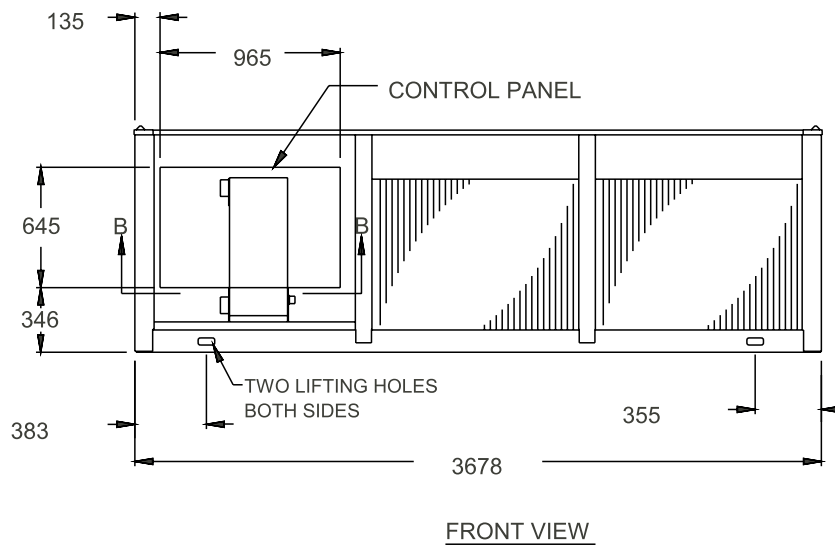
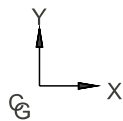
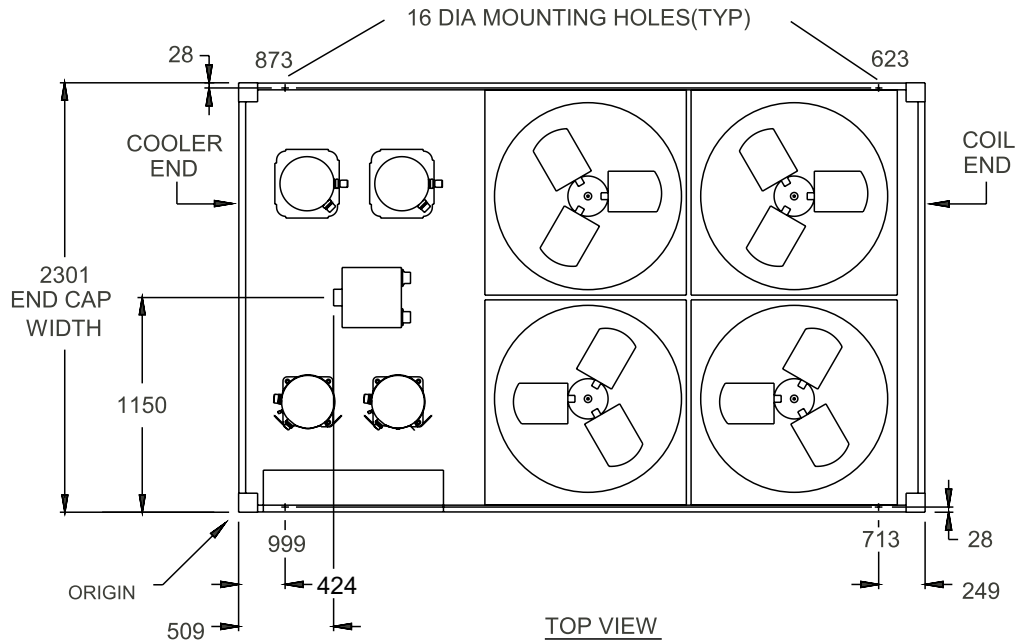

LD18702

Isolator Details (Cont'd)

ONE INCH DEFLECTION, SPRING ISOLATOR CPX-X

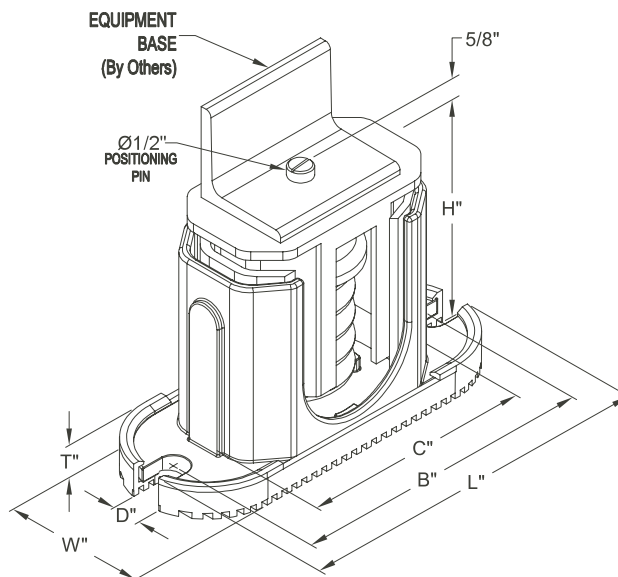

LD18442

MOUNT TYPE	DIMENSION DATA INCHES (MM)						
	W	D	L	B	C	T	H
CP1	3 (76)	0.625 (16)	7.75 (197)	6.5 (165)	4.75 (121)	0.5 (13)	4.625 (117)
CP2	3 (76)	0.625 (16)	10.5 (267)	9.25 (235)	7.75 (197)	0.5625 (14)	6 (152)

MODEL NUMBER	RATED CAPACITY LBS (KG)	DEFLECTION RATED IN (MM)	COLOR CODE
CP1-1D-85	85 (39)	1020 (463)	LT. PURPLE
CP1-1D-120	120 (54)	1.2 (30)	DK. YELLOW
CP1-1D-175	175 (79)	1.17 (30)	DK. BLUE
CP1-1D-250	250 (113)	1.4 (36)	YELLOW
CP1-1D-340	340 (154)	1.13 (29)	RED
CP1-1D-510	510 (231)	1.02 (26)	BLACK
CP1-1D-675	675 (306)	1.32 (34)	DK. PURPLE
CP1-1D-900	900 (408)	1.02 (26)	DK. GREEN
CP1-1D-1200	1200 (544)	0.9 (23)	GRAY
CP1-1D-1360	1360 (617)	0.77 (20)	WHITE
CP1-1D-1785N	1785 (810)	0.88 (22)	GRAY/RED

MODEL NUMBER	RATED CAPACITY LBS (KG)	DEFLECTION RATED IN (MM)	COLOR CODE
CP2-1D-1020	1020 (463)	1.020 (46)	BLACK
CP2-1D-1350	1350 (612)	1.32 (34)	DK. PURPLE
CP2-1D-1800	1800 (816)	1.02 (26)	DK. GREEN
CP2-1D-2400	2400 (1089)	0.9 (23)	GRAY
CP2-1D-2720	2720 (1234)	0.77 (20)	WHITE
CP2-1D-3570N	3570 (1619)	0.88 (22)	GRAY / RED

Isolator Details (Cont'd)

ELASTOMERIC ISOLATOR

RD-1, 2, AND 3 ISOLATORS

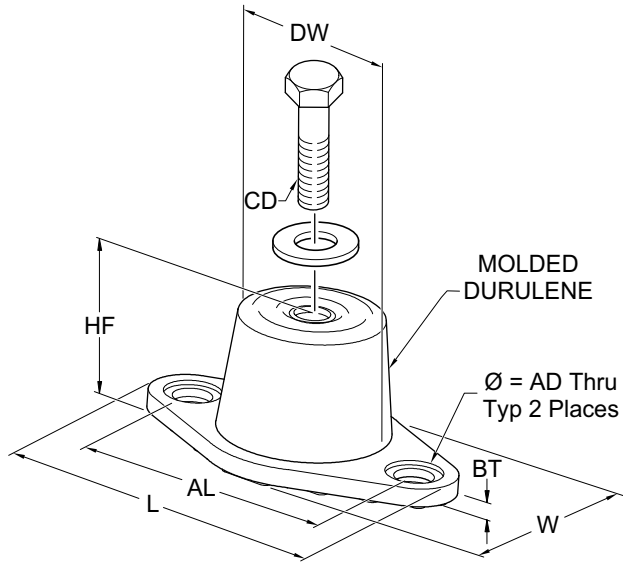

RD-4 ISOLATORS

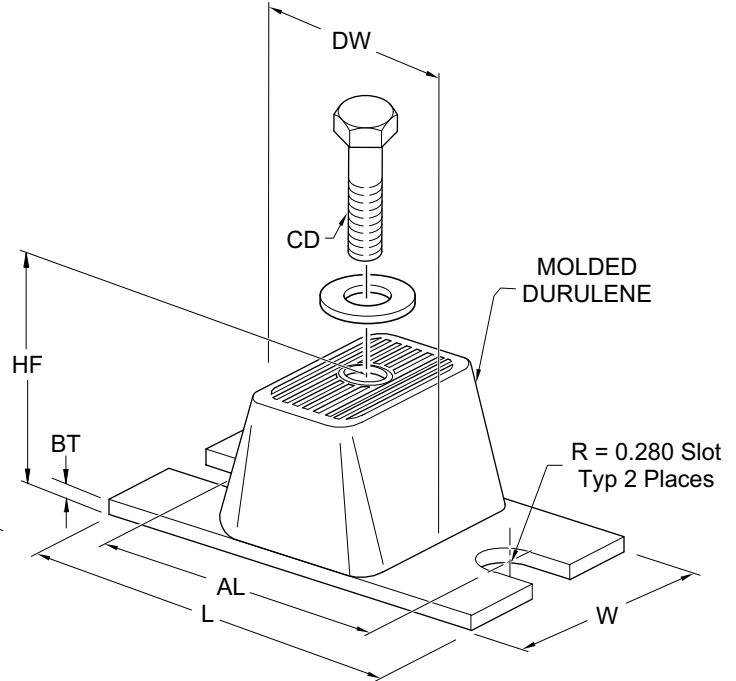

LD17304

MOUNT TYPE	DIMENSION DATA (INCHES)							
	L	W	HF	AL	AD	BT	CD	DW
RD3-WR	5.5 (139.7)	3.38 (85.85)	2.88 (73.15)	4.13 (104.90)	0.56 (14.22)	0.25 (6.35)	1/2-13 UNC X 1	2.5 (63.5)
RD4-WR	6.25 (158.7)	4.63 (117.60)	2.75 (69.85)	5 (127)	0.56 (14.22)	0.38 (9.65)	1/2-13 UNC X 1	3 (76.2)

Isolator Details (Cont'd)**ELASTOMERIC ISOLATOR**

MODEL NUMBER	RATED CAPACITY LBS (KG)	RATED DEFLECTION IN (MM)	DURO (± 5)
RD3-BROWN-WR	250 (113)	0.5 (12)	40
RD3-BRICK RED-WR	525 (238)	0.5 (12)	50
RD3-LIME-WR	750 (340)	0.5 (12)	60
RD3-CHARCOAL-WR	1100 (499)	0.5 (12)	70
MODEL NUMBER	RATED CAPACITY LBS (KG)	RATED DEFLECTION IN (MM)	DURO (± 5)
RD4-BROWN-WR	1500 (680)	0.5 (12)	40
RD4-BRICK RED-WR	2250 (1021)	0.5 (12)	50
RD4-LIME-WR	3000 (1361)	0.5 (12)	60
RD4-CHARCOAL-WR	4000 (1814)	0.5 (12)	70

Electrical Data - 60Hz**QTC2015T - QTC2045T
WIRING WITHOUT PUMP**

QTC2	VOLT	HZ	MIN CKT. AMPS MCA	MIN N/F DISC SW MDSW	MIN DUAL ELEM FUSE	MAX DUAL ELEM FUSE MAX CB	SYSTEM # 1						SYSTEM # 2							
							COMPR 1		COMPR 2		FAN		COMPR 1		COMPR 2		FAN			
							RLA	LRA	RLA	LRA	QTY	FLA	LRA	RLA	LRA	RLA	LRA	QTY	FLA	LRA
015T	200	60	101	150	125	125	42.2	250	42.2	250	2	2.6	5.0	-	-	-	-	-	-	-
	230	60	94	100	110	125	39.0	250	39.0	250	2	2.6	5.0	-	-	-	-	-	-	-
	380	60	54	60	60	70	22.5	155	22.5	155	2	1.6	3.0	-	-	-	-	-	-	-
	460	60	45	60	50	60	18.6	114	18.6	114	2	1.3	2.5	-	-	-	-	-	-	-
	575	60	36	60	40	50	14.9	100	14.9	100	2	1.0	2.0	-	-	-	-	-	-	-
020T	200	60	108	150	125	150	45.4	250	45.4	250	2	2.6	5.0	-	-	-	-	-	-	-
	230	60	100	150	125	125	42.0	250	42.0	250	2	2.6	5.0	-	-	-	-	-	-	-
	380	60	58	60	70	80	24.2	155	24.2	155	2	1.6	3.0	-	-	-	-	-	-	-
	460	60	48	60	60	60	20.0	125	20.0	125	2	1.3	2.5	-	-	-	-	-	-	-
	575	60	39	60	45	50	16.0	100	16.0	100	2	1.0	2.0	-	-	-	-	-	-	-
025T	200	60	136	150	175	175	51.3	300	55.8	425	2	7.6	44.0	-	-	-	-	-	-	-
	230	60	136	150	150	175	51.3	300	55.8	425	2	7.4	19.1	-	-	-	-	-	-	-
	380	60	81	100	90	110	26.9	139	36.0	239	2	4.5	23.1	-	-	-	-	-	-	-
	460	60	65	100	80	90	23.1	150	26.9	187	2	4.0	19.0	-	-	-	-	-	-	-
	575	60	55	60	70	70	19.9	109	23.7	148	2	2.9	15.3	-	-	-	-	-	-	-
030T	200	60	151	200	175	200	59.9	425	59.9	425	2	7.6	30.9	-	-	-	-	-	-	-
	230	60	140	150	175	175	55.5	425	55.5	425	2	7.4	37.0	-	-	-	-	-	-	-
	380	60	81	100	90	110	32.0	239	32.0	239	2	4.5	22.3	-	-	-	-	-	-	-
	460	60	67	100	80	90	26.4	187	26.4	187	2	3.4	17.2	-	-	-	-	-	-	-
	575	60	54	60	60	70	21.1	148	21.1	148	2	2.9	14.6	-	-	-	-	-	-	-

See Electrical Notes on page 54

Electrical Data - 60Hz (Cont'd)

QTC2015T - QTC2045T WIRING WITHOUT PUMP

QTC2	VOLT	HZ	MIN CKT. AMPS MCA	MIN N/F DISC SW MDSW	MIN DUAL ELEM FUSE	MAX DUAL ELEM FUSE MAX CB	SYSTEM # 1						SYSTEM # 2							
							COMPR 1		COMPR 2		FAN		COMPR 1		COMPR 2		FAN			
							RLA	LRA	RLA	LRA	QTY	FLA	LRA	RLA	LRA	RLA	LRA	QTY	FLA	LRA
035T	200	60	224	250	250	250	45.4	250	45.4	250	2	7.6	30.9	45.4	250	45.4	250	2	7.6	30.9
	230	60	209	250	225	250	42.0	250	42.0	250	2	7.4	37.0	42.0	250	42.0	250	2	7.4	37.0
	380	60	121	150	150	150	24.2	155	24.2	155	2	4.5	22.3	24.2	155	24.2	155	2	4.5	22.3
	460	60	99	150	110	110	20.0	125	20.0	125	2	3.4	17.2	20.0	125	20.0	125	2	3.4	17.2
	575	60	80	100	90	90	16.0	100	16.0	100	2	2.9	14.6	16.0	100	16.0	100	2	2.9	14.6
040T	200	60	228	250	250	250	47.0	250	47.0	250	2	7.6	30.9	45.4	250	45.4	250	2	7.6	30.9
	230	60	212	250	225	250	43.5	250	43.5	250	2	7.4	37.0	42.0	250	42.0	250	2	7.4	37.0
	380	60	123	150	150	150	25.1	155	25.1	155	2	4.5	22.3	24.2	155	24.2	155	2	4.5	22.3
	460	60	101	150	110	110	20.7	125	20.7	125	2	3.4	17.2	20.0	125	20.0	125	2	3.4	17.2
	575	60	81	100	90	90	16.6	100	16.6	100	2	2.9	14.6	16.0	100	16.0	100	2	2.9	14.6
045T	200	60	248	400	300	300	51.3	300	51.3	300	2	7.6	44.0	51.3	300	51.3	300	2	7.6	44.0
	230	60	248	400	300	300	51.3	300	51.3	300	2	7.4	19.1	51.3	300	51.3	300	2	7.4	19.1
	380	60	132	150	150	150	26.9	139	26.9	139	2	4.5	23.1	26.9	139	26.9	139	2	4.5	23.1
	460	60	114	150	125	125	23.1	150	23.1	150	2	4.0	19.0	23.1	150	23.1	150	2	4.0	19.0
	575	60	96	150	110	110	19.9	109	19.9	109	2	2.9	15.3	19.9	109	19.9	109	2	2.9	15.3

See Electrical Notes on page 54

Electrical Notes

UNIT VOLTAGE	UNIT VOLTAGE	CONTROL POWER	MCA ¹	OVER CURRENT PROTECTION ²		NF DISC SW
				MIN	MAX	
MODELS WITHOUT CONTROL TRANSFORMER	-	115-1-60	15A	10A	15A	30 A / 240V
MODELS WITH CONTROL TRANSFORMER	-17	200-1-60	15A	10A	15A	30 A / 240V
	-28	230-1-60	15A	10A	15A	30 A / 240V
	-40	380-1-60	15A	10A	15A	30 A / 480V
	-46	460-1-60	15A	10A	15A	30 A / 480V
	-58	575-1-60	15A	10A	15A	30 A / 600V

NOTE:

1. Minimum #14 AWG, 75°C, Copper Recommended

2. Minimum and Maximum Over Current Protection, Dual Element Fuse or Circuit Breaker

VOLTAGE CODE	UNIT POWER	MIN.	MAX.
-17	200-3-60	180	220
-28	230-3-60	207	253
-40	380/415-3-60	342	440
-46	460-3-60	414	506
-58	575-3-60	517	633

LEGEND

ACR	LINE ACROSS THE LINE START
C.B	CIRCUIT BREAKER
D.E	DUAL ELEMENT FUSE
DISC SW	DISCONNECT SWITCH
FACT MOUNT CB	FACTORY MOUNTED CIRCUIT BREAKER
FLA	FULL LOAD AMPS
HZ	HERTZ
MAX	MAXIMUM
MCA	MINIMUM CIRCUIT AMPACITY
MIN	MINIMUM
MIN	NF MINIMUM NON FUSED
RLA	RATED LOAD AMPS
S.P. WIRE	SINGLE POINT WIRING
UNITED MTD SERV SW	UNITED MOUNTED SERVICE (NON-FUSED DISCONNECT SWITCH)
LRA	LOCKED ROTOR AMPS

Electrical Notes (Cont'd)

1. Minimum Circuit Ampacity (MCA) is based on 125% of the rated load amps for the largest motor plus 100% of the rated load amps for all other loads included in the circuit, per NEC Article 430-24. If the optional Factory Mounted Control Transformer is provided, add the following MCA values to the electrical tables for the system providing power to the transformer: -17, add 2.5 amps; -28, add 2.3 amps; -40, add 1.5 amps, -46, add 1.3 amps; -58, add 1 amp.
2. The minimum recommended disconnect switch is based on 115% of the rated load amps for all loads included in the circuit, per NEC Article 440.
3. Minimum fuse size is based upon 150% of the rated load amps for the largest motor plus 100% of the rated load amps for all other loads included in the circuit to avoid nuisance trips at start-up due to lock rotor amps. It is not recommended in applications where brown outs, frequent starting and stopping of the unit, and/or operation at ambient temperatures in excess of 95°F (35°C) is anticipated.
4. Maximum fuse size is based upon 225% of the rated load amps for the largest motor plus 100% of the rated load amps for all other loads included in the circuit, per NEC Article 440-22.
5. Circuit breakers must be UL listed and CSA certified and maximum size is based on 225% of the rated load amps for the largest motor plus 100% of the rated load amps for all other loads included in the circuit. Otherwise, an HACR-type circuit breakers must be used. Maximum HACR circuit breaker rating is based on 225% of the rated load amps for the largest motor plus 100% of the rated load amps for all other loads included in the circuit.
6. The "INCOMING WIRE RANGE" is the minimum and maximum wire size that can be accommodated by the unit wiring lugs. The (2) preceding the wire range indicates the number of termination points available per phase of the wire range specified. Actual wire size and number of wires per phase must be determined based on the National Electrical Code, **using copper connectors only**. Field wiring must also comply with local codes.
7. A ground lug is provided for each compressor system to accommodate a field grounding conductor per NEC Table 250-95. A control-circuit-grounding lug is also supplied.
8. The supplied disconnect is a "Disconnecting Means" as defined in the NEC 100, and is intended for isolating the unit for the available power supply to perform maintenance and troubleshooting. This disconnect is not intended to be a Load Break Device.
9. Field Wiring by others which complies to the National Electrical Code & Local Codes.

Circuit Breaker Calculations

Max Dual Elem Fuse Max CB (MOP)

$$= 2.25 \times \text{Current of largest motor} + \sum (\text{remaining FLAs or RLAs})$$

For this name plate the formula below was used:

$$= 2.25 * \text{RLACpr1} + \text{RLACpr2} + \text{RLACpr3} + \text{Qty} * \text{RLAFans} + 0.49 + \text{FLA}$$

Pump

This formula will calculate the ACTUAL MOP but a table is referenced to provide the appropriate MOP. Using an approximate match, look up the value of the calculated ACTUAL MOP in Column A. Find the largest value i.e. less than or equal to the value in Column A. Once found, the value in Column C which shares the same row is the valued USED in the system. e.g. Using the same example that was used to calculate the MCA, calculate the MOP:

Answer: ACTUAL = $2.25 * 20.4 + 20.4 + 0 + 2 * 2.6 + 5.29 = 45.9 + 30.89 = 76.79$ Comparing against values in Column A: $70 < 76.79 < 80$, therefore the USED MOP found in Column C is 70.

ACTUAL COLUMN A	MINIMUM COLUMN B*	MAXIMUM COLUMN C
0	15	0
15	20	15
20	25	20
25	30	25
30	35	30
35	40	35
40	45	40
45	50	45
50	60	50
60	70	60
70	80	70
80	90	80
90	100	90
100	110	100
110	125	110
125	150	125
150	175	150
175	200	175
200	225	200
225	250	225
250	300	250
300	350	300
350	400	350

*Note: Column B is used to calculate the Minimum Dual Elem Fuse which is not relevant to this exercise.

Power Wiring

LEGEND

- △ = CTBI
- ⊙ = TBI
- - - = FIELD WIRING
- - - = OPTIONAL WIRING

**ELEMENTARY DIAGRAM
CONTROL CIRCUIT**

035-20964-101
REV. D

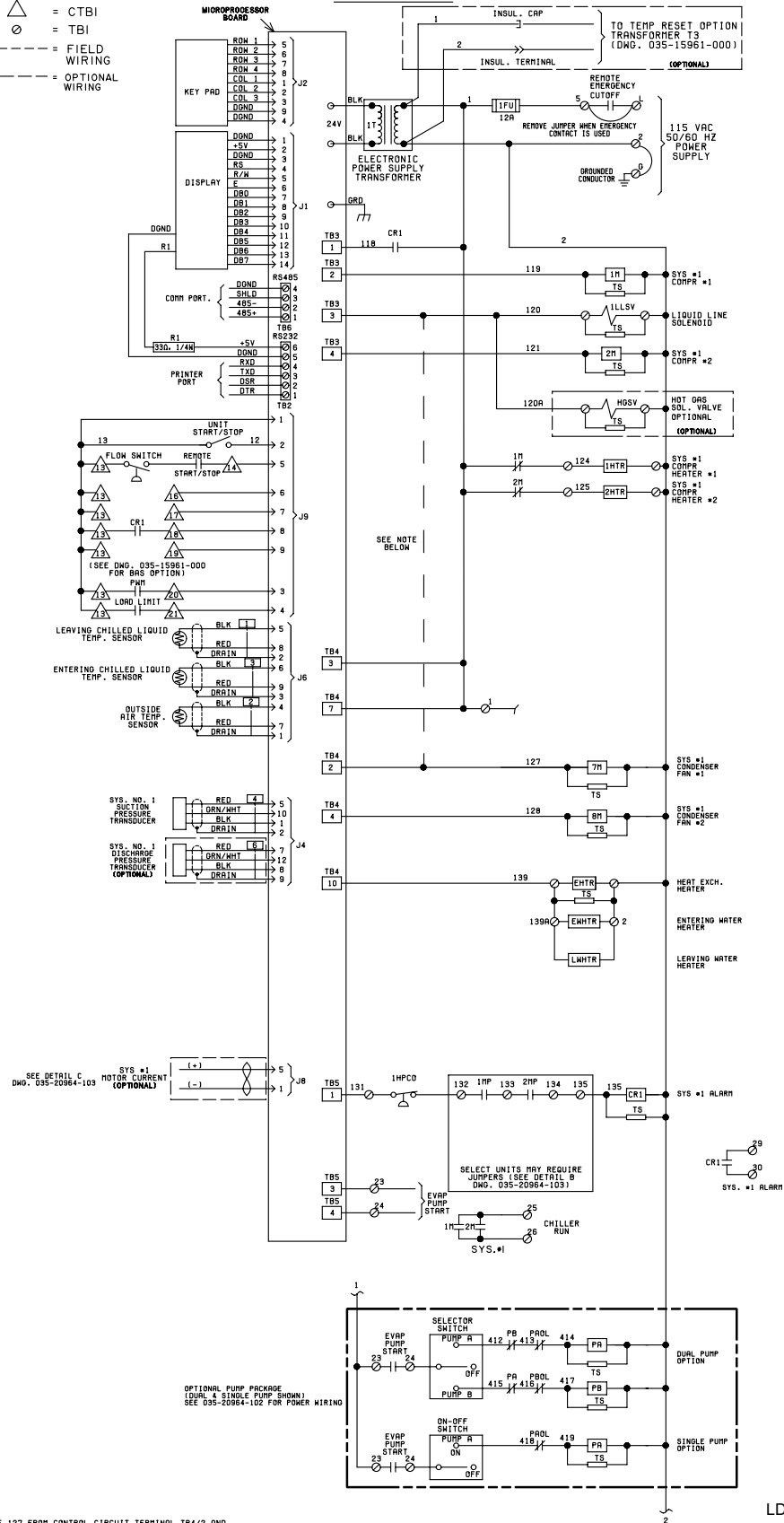

NOTE:

FOR LOW AMBIENT KIT, REMOVE WIRE 127 FROM CONTROL CIRCUIT TERMINAL TB4/2 AND RECONNECT IT TO TB3/3.

LD18707

Power Wiring (Cont'd)

ELEMENTARY DIAGRAM

035-20964-102
REV. B

POWER CIRCUIT

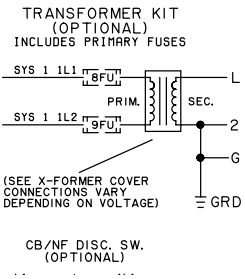
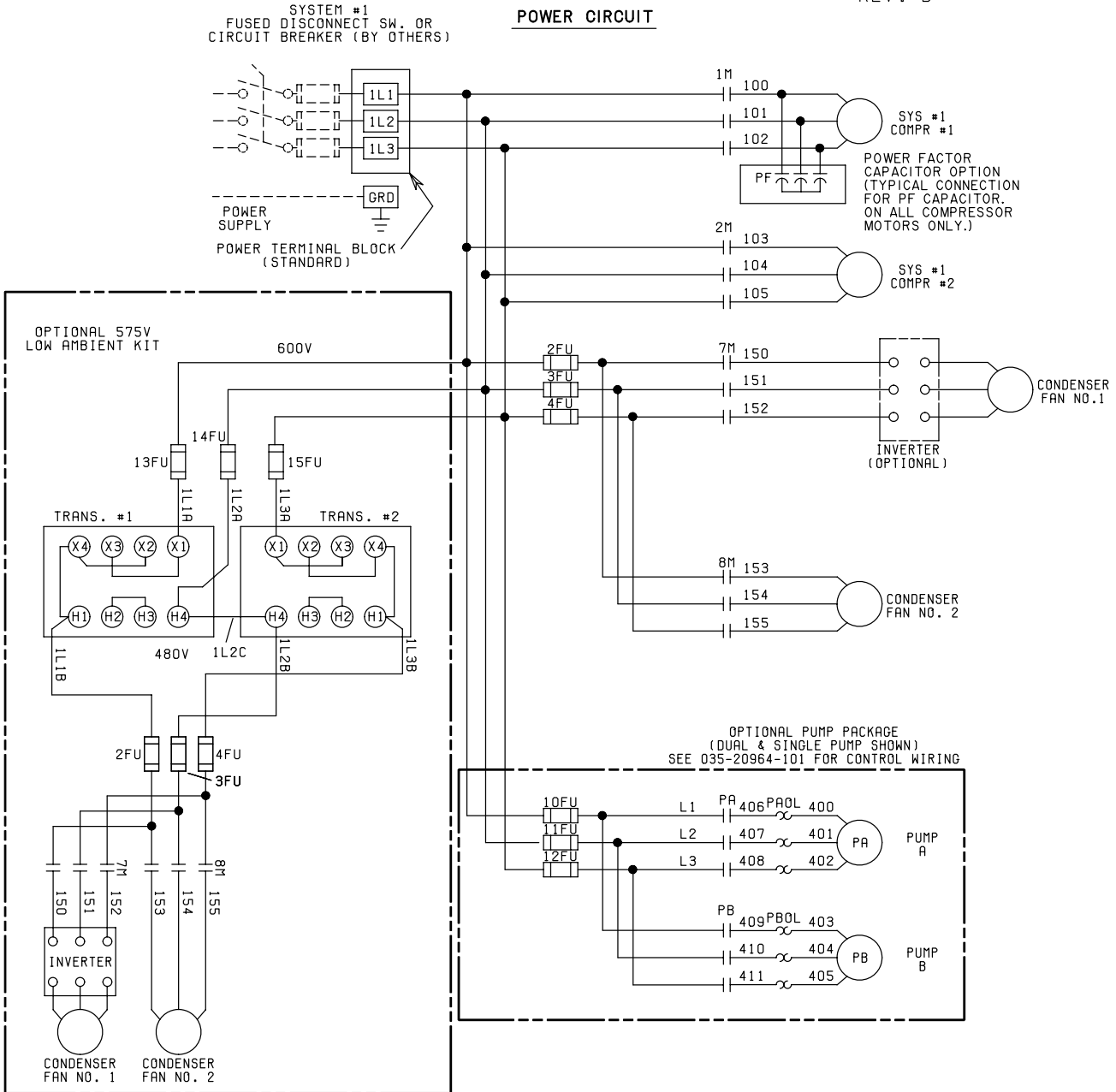

Power Wiring (Cont'd)

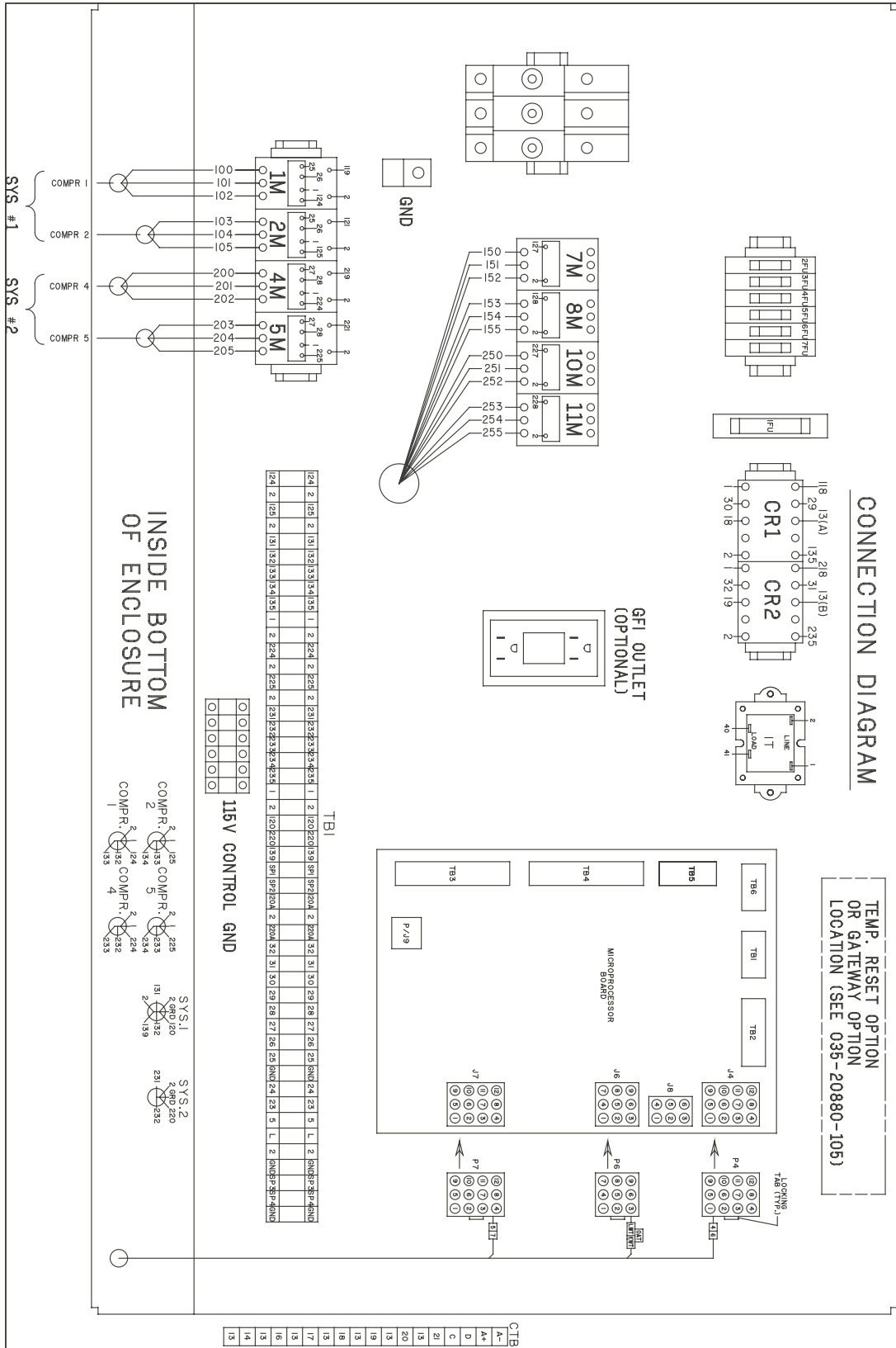

LD18746

Control Wiring

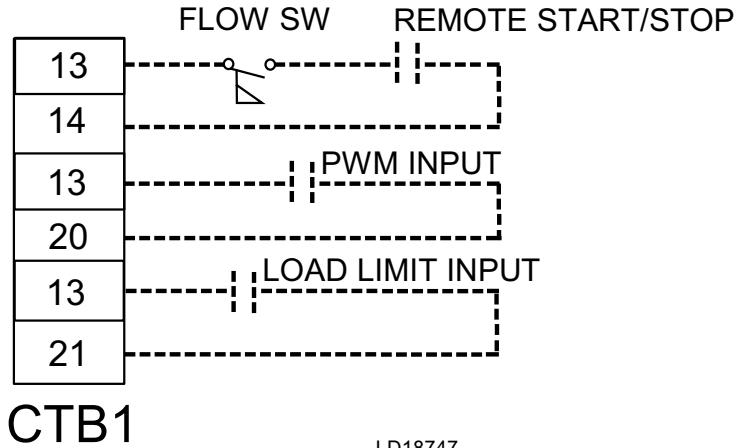

LD18747

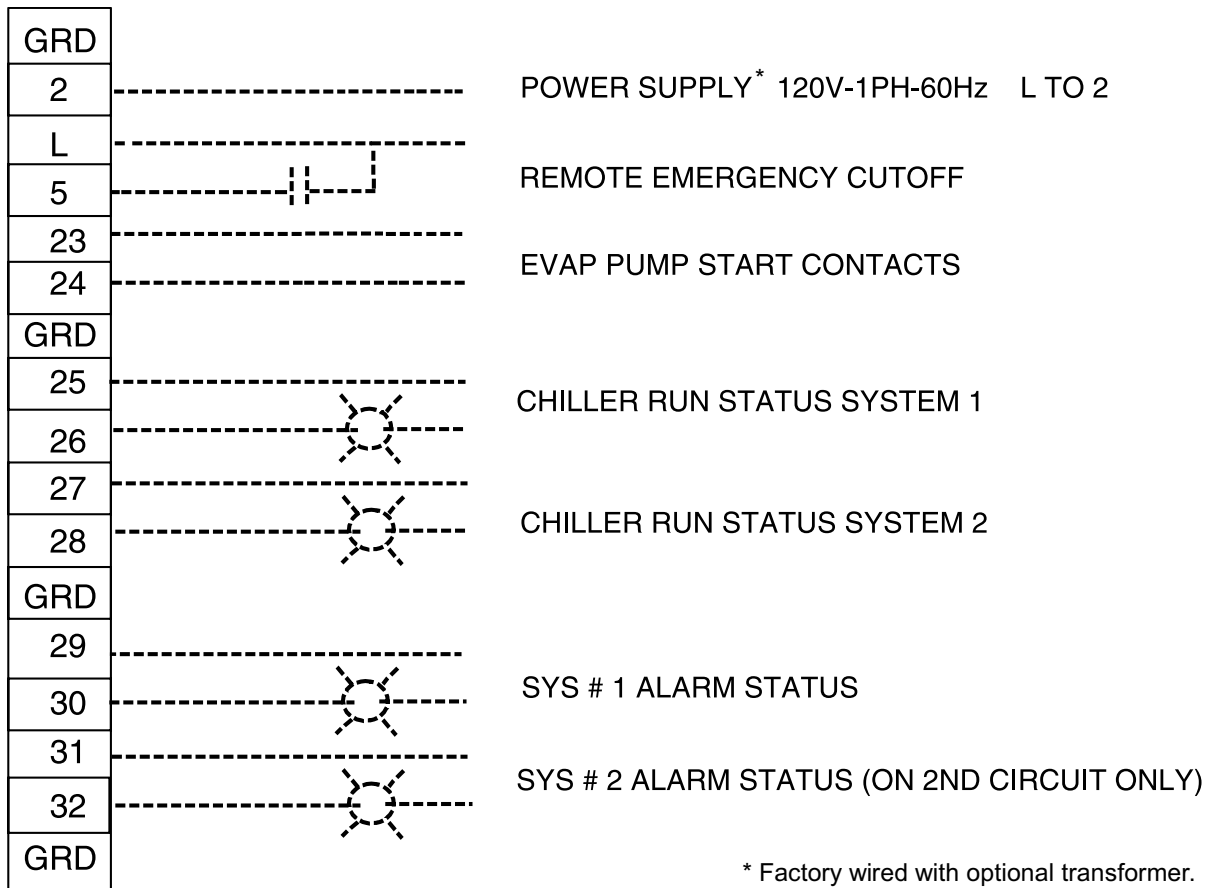

CTB2

LD03611

Application Data

UNIT LOCATION

The QTC2 chillers are designed for outdoor installation. When selecting a site for installation, be guided by the following conditions:

1. For outdoor locations of the unit, select a place having an adequate supply of fresh air for the condenser.
2. Avoid locations beneath windows or between structures where normal operating sounds may be objectionable.
3. Installation sites may be either on a roof, or at ground level. (See FOUNDATION.)
4. The condenser fans are the propeller-type, and are not recommended for use with duct work in the condenser air stream.
5. When it is desirable to surround the unit(s), the screening is able to pass the required chiller CFM without exceeding 0.1" of water external static pressure.
6. Protection against corrosive environments is available by supplying the units with either copper fin, cured epoxy-dipped, or epoxy-coated fins on the condenser coils. The epoxy-dipped or epoxy-coated coils should be offered with any units being installed at the seashore or where salt spray may hit the unit.

In installations where winter operation is intended and snow accumulations are expected, additional height must be provided to ensure normal condenser air flow.

Recommended clearances for units are given in *Unit Dimensions - English on page 20*. When the available space is less, the unit(s) must be equipped with the discharge pressure transducer option to permit high pressure unloading in the event that air recirculation were to occur.

FOUNDATION

The unit is mounted on a flat and level foundation, ground or roof, capable of supporting the entire operating weight of the equipment. Operating weights are given in the *Physical Data and Nominal Ratings on page 16* tables.

ROOF LOCATIONS – Choose a spot with adequate structural strength to safely support the entire weight of the unit and service personnel. Care must be taken not to damage the roof during installation. If the roof is “bonded”, consult the building contractor or architect for special installation requirements. The roof installations incorporate the use of spring-type isolators to minimize the transmission of vibration into the building structure.

GROUND LEVEL INSTALLATIONS – It is important that the units be installed on a substantial base that will not settle, causing strain on the liquid lines and resulting in possible leaks. A one-piece concrete slab with footers extending below the frost line is highly recommended. Additionally, do not tie the slab to the main building foundation, as noises will telegraph.

Application Data (Cont'd)

Mounting holes (11/16" diameter) are provided in the steel channel for bolting the unit to its foundation. See *Unit Dimensions - English on page 20*.

For ground level installations, take precaution taken to protect the unit from tampering by or injury to unauthorized persons. Screws on access panels will prevent casual tampering; however, further safety precautions, such as unit enclosure options, a fenced-in enclosure, or locking devices on the panels may be advisable. Check local authorities for safety regulations.

CHILLED LIQUID PIPING

The chilled liquid piping system is laid out so that the circulating pump discharges into the cooler. The inlet and outlet cooler liquid connections are given in DIMENSIONS.

Hand stop valves are recommended for use in all lines to facilitate servicing. Drain connections are provided at all low points to permit complete drainage of the cooler and system piping.

The cooler must be protected by a strainer, preferably of 40 mesh, fitted as close as possible to the liquid inlet connection, and provided with a means of local isolation. The cooler must not be exposed to flushing velocities or debris released during flushing. It is recommended that a suitably sized bypass and valve arrangement is installed to allow flushing of the piping system. The bypass can be used during maintenance to isolate the heat exchanger o other units.

Pressure gauge connections are recommended for installation in the inlet and outlet water lines. Gauges are not furnished with the unit and are to be furnished by other suppliers.

The chilled liquid lines that are exposed to outdoor ambients should be wrapped with a supplemental heater cable and covered with insulation. As an alternative, ethylene glycol is added to protect against freezeup during low ambient periods.

A flow switch is available as an accessory on all units. The flow switch (or its equivalent) must be installed in the leaving water piping of the cooler and must not be used to start and stop the unit.

Application Data (Cont'd)

TYPICAL PIPING FOR BRAZED-PLATE COOLERS

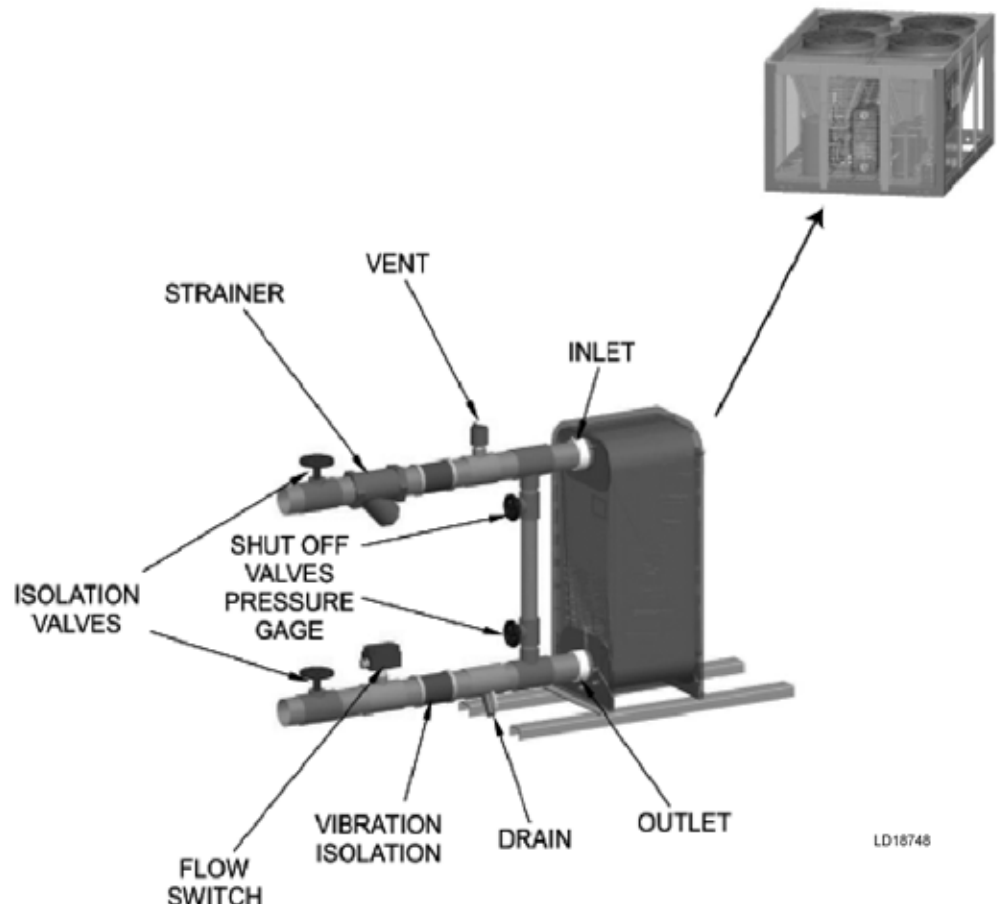

Notes:

1. Placement on a level surface free of obstructions (including snow, for winter operation) or air recirculation ensures rated performance, reliable operation and ease of maintenance.
2. Piping and wiring shown is for reference use only and is not in accordance with any national or local standards.
3. All wiring and piping must comply with applicable local and national codes.
4. All wiring and piping must follow standard piping techniques as discussed in the ASHRAE handbook.
5. A strainer with a mesh size between .5 and 1.5 mm is recommended upstream of the heat exchanger to prevent clogging.

Guide Specifications

PART 1 – GENERAL

1.01 SCOPE

- A. The requirements of the General Conditions, Supplementary Conditions, Division 1, and Drawings apply to all Work herein.
- B. Provide Microprocessor controlled, multiple-scroll compressor, air-cooled, liquid chillers of the scheduled capacities as shown and indicated on the Drawings, including but not limited to:
 - 1. Chiller package
 - 2. Electrical power and control connections
 - 3. Chilled water connections
 - 4. Change of refrigerant oil (for factory mounted evaporator) or (evaporator shipped separately for field installation and piping by contractor)

1.02 QUALITY ASSURANCE

- A. Products shall be Designed, Tested, Rated and Certified in accordance with, and installed in compliance with applicable sections of the following Standards and Codes:
 - 1. ANSI/ASHRAE Standard 15 – Safety Code for Mechanical Refrigeration
 - 2. ASHRAE 90.1– Energy Efficiency compliance.
 - 3. ANSI/NFPA Standard 70 – National Electrical Code (NEC).
 - 4. ASME Boiler & Pressure Vessel Code, Section VIII, Division 1.
 - 5. AHRI Standard 550/590 – Positive Displacement Compressors and Air Cooled Rotary Screw Water-Chilling Packages.
 - 6. Conform to Intertek Testing Services, formerly ETL, for construction of chillers and provide ETL/cETL Listing label.
 - 7. Manufactured in facility registered to ISO9002.
 - 8. OSHA - Occupational Safety and Health Act
- B. Factory Test: Chiller shall be pressure-tested, evacuated and fully charged with refrigerant and oil, and shall be factory operational run tested with water flowing through the vessel.
- C. Chiller manufacturer shall have a factory trained and supported service organization that is within a 50 mile radius of the site.
- D. Manufacturer shall Warrant all equipment and material of its manufacture against defects in workmanship and material for a period of one year from date of initial start-up or eighteen (18) months from date of shipment, whichever occurs first.

Guide Specifications (Cont'd)

1.03 DELIVERY AND HANDLING

- A. Unit shall be delivered to job site fully assembled, and charged with refrigerant and oil by the Manufacturer. (Contractor is responsible for providing and installing the refrigerant charge including the charge required for the field installed interconnecting piping. Chiller components shall ship with a dry nitrogen holding charge – Remote Evaporator option).
- B. Unit shall be stored and handled per Manufacturer's instructions.

PART 2 - PRODUCTS

2.01 CHILLER MATERIALS AND COMPONENTS

- A. General: Install and commission, as shown on the schedules and plans, factory assembled, charged, and tested air cooled scroll compressor chiller(s) as specified herein. Chiller shall be designed, selected, and constructed using a refrigerant with Flammability rating of "1", as defined by ANSI/ASHRAE STANDARD - 34 Number Designation and Safety Classification of Refrigerants. Chiller shall include, but is not limited to a complete system with a single refrigerant circuit 35 tons (123kW) and below, and not less than two refrigerant circuits above 35 tons (123kW), scroll compressors, direct expansion type evaporator, air-cooled condenser, refrigerant, lubrication system, interconnecting wiring, safety and operating controls including capacity controller, control center, motor starting components, and special features as specified herein or required for safe, automatic operation.
- B. Cabinet: External structural members shall be constructed of heavy gauge, galvanized steel coated with baked on powder paint which, when subject to ASTM B117, 1000 hour, 5% salt spray test, yields minimum ASTM 1654 rating of "6". Add Wire Panels of heavy gauge, welded wire-mesh, coated to resist corrosion, to protect condenser coils from incidental damage and restrict unauthorized access to internal components. Factory installed.

2.02 COMPRESSORS

Compressors: Shall be hermetic, scroll-type, including:

1. Compliant design with axial and radial sealing.
2. Refrigerant flow through the compressor with 100% suction cooled motor.
3. Large suction side free volume and oil sump to provide liquid handling capability.
4. Compressor crankcase heaters to provide extra liquid migration protection.
5. Annular discharge check valve and reverse vent assembly to provide low pressure drop, silent shutdown and reverse rotation protection.
6. Initial Oil charge.
7. Oil Level sight glass.
8. Vibration isolator mounts for compressors.
9. Brazed-type connections for fully hermetic refrigerant circuits.

Guide Specifications (Cont'd)

2.03 REFRIGERANT CIRCUIT COMPONENTS

Each refrigerant circuit shall include liquid line shutoff valve with charging port, low side pressure relief device, filter-drier, solenoid valve, sight glass with moisture indicator, expansion valves, and flexible, closed-cell foam insulated suction line. Unit also includes service isolation valves as standard.

2.04 HEAT EXCHANGERS

A. Evaporator:

1. Evaporator shall be brazed-plate stainless steel construction, single or dual circuit heat exchangers capable of refrigerant working pressure of 650 psig (3103 kPa) and liquid side pressure of 150 psig (1034 kPa)
2. Evaporator shall be covered in 3/4" (19mm) flexible, closed cell insulation, thermal conductivity of 0.26k (BTU/HR-FT²-°F)/in.) maximum.
3. Cooler shall have thermostatically controlled heaters to protect to -20°F (29°C) ambient in off-cycle.
4. Brazed plate heat exchangers shall be UL listed.
5. Installing contractor must include accommodations in the chilled water piping to allow proper drainage and venting of the heat exchanger. A strainer with a mesh size between 0.5 and 1.5mm (40 mesh) is recommended upstream of the heat exchanger to prevent clogging.

B. Air Cooled Condenser:

1. Coils: Internally enhanced, seamless copper tubes, mechanically expanded into aluminum alloy fins with full height collars. Subcooling coil an integral part of condenser. Design working pressure shall be 650 PSIG (45 barg).
2. Low Noise Fans: Shall be dynamically and statically balanced, direct drive, propeller type fan, providing vertical air discharge and low sound. Each fan in its own compartment to prevent crossflow during fan cycling. Guards of heavy gauge, PVC (polyvinyl chloride) coated or galvanized steel.

[OPTIONAL]: Ultra-Quiet Fans

3. Fan Motors: High efficiency, direct drive, 6 pole, 3 phase, insulation class "F", current protected, Totally Enclosed Air-Over (TEAO), rigid mounted, with double sealed, permanently lubricated, ball bearings.

2.05 CONTROLS

- A. General: Automatic start, stop, operating, and protection sequences across the range of scheduled conditions and transients.
- B. Microprocessor Enclosure: Rain and dust tight NEMA 3R/12 powder painted steel cabinet with a gasket sealed protective cover.

Guide Specifications (Cont'd)

C. Microprocessor Control Center:

1. Automatic control of compressor start/stop, anti-coincidence and anti-recycle timers, automatic pump-down on shutdown, condenser fans, evaporator pump, evaporator heater, unit alarm contacts, and chiller operation from 0°F to 125°F (-18°C to 52°C) ambient. Automatic reset to normal chiller operation after power failure.
 2. Remote water temperature reset via a Pulse Width Modulated (PWM) input signal or up to two steps of demand (load) limiting.
 3. Software stored in non-volatile memory, with programmed setpoints retained in lithium battery backed real time clock (RTC) memory for minimum 5 years.
 4. Forty character liquid crystal display, descriptions in English (or Spanish, French, Italian, or German), numeric data in English (or Metric) units. Sealed keypad with sections for Setpoints, Display/Print, Entry, Unit Options & clock, and On/Off Switch.
 5. Programmable Setpoints (within Manufacturer limits): display language; chilled liquid temperature setpoint and range, remote reset temperature range, set daily schedule/holiday for start/ stop, manual override for servicing, low and high AMBI-ENT °Cutouts, number of compressors, low liquid temperature cutout, low suction pressure cutout, high discharge pressure cutout, anti-recycle timer (compressor start cycle time), and anti-coincident timer (delay compressor starts).
 6. Display Data: Return and leaving liquid temperatures, low leaving liquid temperature cut out setting, low ambient temperature cutout setting, outdoor air temperature, English or metric data, suction pressure cutout setting, each system suction pressure, discharge pressure, liquid temperature reset via a Quantech ISN DDC or building automation system (by others) via PWM input as standard or a 4-20 milliamp or 0- 10 VDC input or contact closure with optional BAS interface, anti-recycle timer status for each compressor, anti-coincident system start timer condition, compressor run status, no cooling load condition, day, date and time, daily start/ stop times, holiday status, automatic or manual system lead/lag control, lead system definition, compressor starts/operating hours (each), status of hot gas valves, evaporator heater and fan operation, run permissive status, number of compressors running, liquid solenoid valve status, load & unload timer status, water pump status.
 7. System Safeties: Shall cause individual compressor systems to perform auto shut down; manual reset required after the third trip in 90 minutes. Includes: high discharge pressure, low suction pressure, high pressure switch, and motor protector. Compressor motor protector shall protect against damage due to high input current or thermal overload of windings.
 8. Unit Safeties: Shall be automatic reset and cause compressors to shut down if low ambient, low leaving chilled liquid temperature, under voltage, and flow switch operation. Contractor shall provide flow switch and wiring per chiller manufacturer requirements.
 9. Alarm Contacts: Low ambient, low leaving chilled liquid temperature, low voltage, low battery, and (per compressor circuit): high discharge pressure, and low suction pressure.
- D. Manufacturer shall provide any controls not listed above, necessary for automatic chiller operation. Mechanical Contractor shall provide field control wiring necessary to interface sensors to the chiller control system.

Guide Specifications (Cont'd)

2.06 POWER CONNECTION AND DISTRIBUTION

A. Power Panels:

1. NEMA 3R, powder painted steel cabinets with a gasketed protective cover. Provide main power connection(s), control power connections, compressor and fan motor start contactors, current overloads, and factory wiring.
2. Power supply shall enter unit at a single location, be 3 phase of scheduled voltage, and connect to individual terminal blocks per compressor. Separate disconnecting means and/or external branch circuit protection (by Contractor) required per applicable local or national codes.

B. Compressor, control and fan motor power wiring shall be fully contained within the unit enclosure, or shall be routed through liquid tight conduit.

2.07 ACCESSORIES AND OPTIONS

Some accessories and options supercede standard product features. Your Quantech representative will be pleased to provide assistance.

A. Microprocessor controlled, Factory installed Across-the-Line type compressor motor starters as standard.

B. Outdoor Ambient Temperature Control

1. Low Ambient Control: Permits unit operation to 0°F ambient.
2. High AMBIENT Control: Permits unit operation above 115°F ambient.

C. Power Supply Connections:

1. Single Point or Disconnect: Single or Dual point Non-Fused Disconnect(s) and lockable external handle (in compliance with Article 440-14 of NEC) can be supplied to isolate the unit power voltage for servicing. Separate external fusing must be supplied, by others, in the incoming power wiring, which must comply with the National Electric Code and/or local codes.
2. Single Point Circuit Breaker: Single point Terminal Block with Circuit Breaker and lockable external handle (in compliance with Article 44014 of NEC) can be supplied to isolate power voltage for servicing. Incoming power wiring must comply with the National Electric Code and/or local codes. Single Point Circuit Breakers available on QTC2015T-045T models.

D. Pressure Transducers and Readout Capability

1. Discharge Pressure Transducers: Permits unit to sense and display discharge pressure.

E. Control Power Transformer: Converts unit power voltage to 120-1-60 or 120-1-50 for 50hz (500 VA capacity). Factory- mounting includes primary and secondary wiring between the transformer and the control panel.

F. Condenser Coil Environmental Protection:

1. Pre-Coated: Epoxy coated aluminum fin stock to guard from corrosive agents and insulate against galvanic potential. For mild seashore or industrial locations.

Guide Specifications (Cont'd)

2. Post-Coated Dipped: Dipped-cured coating on condenser coils for seashore and other corrosive applications (with the exception of strong alkalis, oxidizers, and wet bromine, chlorine and fluorine in concentrations greater than 100ppm).
- G. Protective Chiller Panels (Factory or Field Mounted)
1. Louvered Panels (condenser coils only): Painted steel as per remainder of unit cabinet, over external condenser coil faces.
 2. Wire Panels (full unit): Heavy gauge, welded wire-mesh, PVC -coated to resist corrosion, to protect condenser coils from incidental damage and restrict unauthorized access to internal components.
 3. Louvered Panels (full unit): Painted steel as per remainder of unit cabinet, to protect condenser coils from incidental damage, visually screen internal components, and prevent unauthorized access to internal components.
 4. Louvered/Wire Panels: Louvered steel panels on external condenser coil faces, painted as per remainder of unit cabinet. Heavy gauge, welded wire-mesh, coated to resist corrosion, around base of machine to restrict unauthorized access.
- H. Flow Switch (Field-mounted): Vapor proof SPDT, NEMA 4X switch (150 PSIG), -20°F to 250°F.
- I. Differential Pressure Switch: Alternative to an above mentioned flow switch. A 300 psi maximum working pressure SPDT 5 amp 125/250VAC switch, with a range of 3-45 PSIG (0.2-3 barg), deadband 0.5 - 0.8 psi, with 1/4" NPTE Pressure Connections.
- J. Evaporator options:
1. Provide 1½" cooler insulation in lieu of standard ¾".
 2. Provide Raised Face Flanges for field installation on cooler nozzles and field piping:
 - a. 150 PSIG, welded Flanges.
- K. Service Isolation valves: Service suction and discharge (ball type) isolation valves are added to unit per system. This option also includes a system high pressure relief valve in compliance with ASHRAE 15.
- L. Remote Cooler: Manufacturer shall provide separately: chiller less evaporator, leaving and return water sensors, and liquid line components (solenoid valves, filter driers, sight glasses, and TXVs), as discrete elements of a complete factory system. Contractor shall be field erect system and provide interconnecting refrigerant piping and wiring in accordance with Manufacturer recommendations, and project plans and schedules. Where not otherwise specified, Contractor provided system piping shall be in accordance with applicable sections of ASHRAE Handbook.
- M. Hot Gas By-Pass: Permits continuous, stable operation at capacities below the minimum step of unloading to as low as 5% capacity (depending on both the unit & operating conditions) by introducing an artificial load on the cooler. Hot gas by-pass is installed on only one refrigerant circuit (System #1).

Guide Specifications (Cont'd)

N. Microprocessor Membrane Keypad Graphics on in lieu of Standard English:

1. French language.
2. German language.
3. Spanish language.
4. Italian language.

O. Thermal Storage: Leaving chilled liquid setpoint range for charge cycle from 25°F to 20°F minimum, with automatic reset of the leaving brine temperature up to 40°F above the setpoint. (Works with Option T)

P. Low Temperature Process Brine: Leaving chilled liquid setpoint range 20°F to 30°F.

Q. Chicago Code Relief Valves to meet Chicago Code requirements.

R. Building Automation System (EMS) Reset Interface: Chiller to accept 4 to 20mA, 0 to 10 VDC, or discrete contact closure input to reset the leaving chilled liquid temperature.

S. Vibration Isolation (Field-Mounted):

1. Neoprene Pad Isolators.
2. 1-Inch Deflection Spring Isolators: Level adjustable, spring and cage type isolators for mounting under the unit base rails.
3. 2-Inch Deflection Isolators: Level adjustable, restrained mounts in rugged welded steel housing with vertical and horizontal limit stops. Housings shall be designed to withstand a minimum 1.0g accelerated force in all directions to 2 inches.

Guide Specifications (Cont'd)

PART 3 - EXECUTION

3.01 Installation

- A. General: Rig and Install in full accordance with Manufacturers requirements, Project drawings, and Contract documents.
- B. Location: Locate chiller as indicated on drawings, including cleaning and service maintenance clearance per Manufacturer instructions. Adjust and level chiller on support structure. If equipment provided exceeds height of scheduled chiller, installing contractor is responsible for additional costs associated with extending the height of parapet or screening walls/enclosures
- C. Components: Installing Contractor shall provide and install all auxiliary devices and accessories for fully operational chiller.
- D. Electrical: Coordinate electrical requirements and connections for all power feeds with Electrical Contractor (Division 16).
- E. Controls: Coordinate all control requirements and connections with Controls Contractor.
- F. Finish: Installing Contractor shall paint damaged and abraded factory finish with touch-up paint matching factory finish.

