

⚠ WARNING**Risk of Electric Shock.**

Disconnect the power supply before making electrical connections. Contact with components carrying hazardous voltage can cause electric shock and may result in severe personal injury or death.

Disconnect all electric power sources from the CMS-2000 Central Monitoring Station before removing the CMS-2000 Central Monitoring Station cover. Contact with internal components carrying hazardous voltage can cause electric shock and may result in severe personal injury or death.

⚠ CAUTION**Risk of Personal Injury or Property Damage.**

For use in a controlled environment only. Refer to installation instructions for environmental conditions.

NOTICE**Risk of Property Damage.**

Do not apply power to the station before checking all wiring connections. Short circuited or improperly connected wires may result in permanent damage to the equipment.

Risk of Property Damage.

Do not run network communication cables in the same conduit, raceway, or panel with any high-voltage (greater than 30 VAC) wiring. Isolate all network wiring and all network devices from high-voltage wiring and equipment. Failure to isolate network wiring and network devices from high-voltage wiring and equipment can result in damage to network devices or poor network performance.

Risk of Property Damage.

Label all wires prior to disconnecting the equipment. Failure to label the wires may cause improper equipment operation after reconnecting the equipment.

IMPORTANT: Do not install or use this CMS-2000 Central Monitoring Station in or near environments where corrosive substances or vapors could be present. Exposure of the CMS-2000 monitor to corrosive environments may damage the device's internal components and will void the warranty.

IMPORTANT: Do not install this CMS-2000 Central Monitoring Station in condensing, wet, or damp environments. Moisture may cause damage to the CMS-2000 monitor.

IMPORTANT: Only qualified personnel should install or service Johnson Controls® products. These instructions are a guide for such personnel. Carefully follow all instructions in this document and all instructions for the CMS-2000 Central Monitoring Station.

IMPORTANT: Use copper conductors only. Make all wiring connections in accordance with local, national, and regional regulations. Do not exceed the CMS-2000 Central Monitoring Station's electrical ratings.

IMPORTANT: Do not install the CMS-2000 Central Monitoring Station where the maximum temperature exceeds 125°F (52°C). Installing the device where maximum temperatures exceed 125°F (52°C) may cause damage to the CMS-2000 Central Monitoring Station and may void the warranty.

IMPORTANT: Make all wiring connections in accordance with the National Electrical Code and local regulations. Use proper Electrostatic Discharge (ESD) precautions during installation and servicing to avoid damaging the electronic circuits of the CMS-2000 Central Monitoring Station.

IMPORTANT: Maintain proper polarity and voltage or current ratings. Improper polarity or exceeding the voltage or current ratings will void the warranty.

 **AVERTISSEMENT**
Risque de décharge électrique.

Débrancher l'alimentation avant de réaliser tout branchement électrique. Tout contact avec des composants conducteurs de tensions dangereuses risque d'entraîner une décharge électrique et de provoquer des blessures graves, voire mortelles.

Déconnecter toutes les sources d'alimentation électrique du CMS-2000 Central Monitoring Station avant de ouvrir le capot du CMS-2000 Central Monitoring Station. Tout contact avec des composants internes conducteurs de tensions dangereuses risque d'entraîner une décharge électrique et de provoquer des blessures graves, voire mortelles.

 **ATTENTION**
Risque de blessure corporelle ou de dommages matériels.

Pour utilisation dans un environnement contrôlé uniquement. Consulter le guide d'installation pour les conditions environnementales.

NOTICE**Risque de dégâts matériels.**

Ne pas mettre le système sous tension avant d'avoir vérifié tous les raccords de câblage. Des fils formant un court-circuit ou connectés de façon incorrecte risquent d'endommager irrémédiablement l'équipement.

Risque de dégâts matériels.

Ne passez pas les câbles de communication réseau dans les mêmes gaines, chemins de câbles ou panneaux que les câbles à haute tension (supérieure à 30 Vca). Isolez tous les câbles et appareils réseau des câbles et appareils à haute tension. Un défaut d'isolement des câbles et appareils à haute tension peut provoquer des dommages aux appareils réseau et réduire les performances du réseau.

Risque de dégâts matériels.

Étiquetez tous les câbles avant de débrancher l'équipement. Le non-respect de cette précaution peut amener un fonctionnement anormal après redémarrage de l'équipement.

IMPORTANT : N'installez ou n'utilisez pas CMS-2000 Central Monitoring Station dans, ou près, d'environnements où des substances ou vapeurs corrosives peuvent être présentes. L'exposition du CMS-2000 à des environnements corrosifs peut endommager les composants internes de l'appareil et annuler la garantie.

IMPORTANT : N'installez pas CMS-2000 Central Monitoring Station dans un environnement humide, mouillé ou il se produit de la condensation. L'humidité peut causer des dommages au CMS-2000.

IMPORTANT : Seul le personnel qualifié peut installer et entretenir les produits Johnson Controls. Ces instructions constituent un guide pour ce type de personnel. Suivez attentivement toutes les instructions de ce document et toutes les instructions du CMS-2000 Central Monitoring Station.

IMPORTANT : N'utilisez que des conducteurs en cuivre. Assurez-vous que tous les branchements de câbles sont effectués selon les réglementations locales, nationales et régionales. Ne dépassez pas les spécifications électriques du CMS-2000 Central Monitoring Station.

IMPORTANT : N'installez pas le contrôleur d'environnement critique CMS-2000 où la température maximum dépasse 52 °C (125 °F). Installer l'appareil dans un environnement où la température maximum dépasse 52 °C (125 °F) peut endommager CMS-2000 Central Monitoring Station et peut annuler la garantie.

IMPORTANT : Assurez-vous que tous les branchements de câbles sont effectués selon le Code national de l'électricité et les réglementations locales. Utilisez une bonne protection contre les décharges électrostatiques (ESD) pendant l'installation et l'entretien pour éviter d'endommager les circuits électroniques du CMS-2000 Central Monitoring Station.

IMPORTANT : Conservez la bonne polarité et la bonne tension ou le bon courant. Une mauvaise polarité ou le dépassement de la tension ou du courant annulera la garantie.

Table of contents

Contents

Description.....	5
Features and benefits	5
Applications	5
Installing the CMS-2000 Thin Mount display for a retrofit application	6
Installing the CMS-2000 Thin Mount display for a new application.....	9
Display module settings configuration	11
System diagram.....	12
Wiring the CMS-2000 to the nearest FMS-2000C or HMS-1655 Controller.....	13
Technical specifications	14
Mounting hardware	14
Cleaning the display.....	15
North American Emissions Compliance	16
Repair information.....	16

Description

The CMS-2000 Central Monitoring Station provides instant status verification for up to eight rooms, eight fume hoods, or a combination of rooms and hoods. You can use the CMS-2000 as a nurses' station, or to monitor multiple spaces in large laboratories.

The CMS-2000 creates a centralized location to easily access critical information like room pressure, isolation mode, exhaust air flow, face velocity, and alarm status of multiple spaces and fume hoods. If a monitored parameter goes outside its prescribed range, it activates an audible and visual alarm, that alerts staff to the alarm condition. Users can access vital information on a single screen to quickly make informed decisions. This ensures that critical spaces are safe for occupancy.

The CMS-2000 features the 360° Safety Halo edge lighting, which you can use to monitor status down long corridors with a simple glance. The green, yellow, and red visual alarms also help to reduce audible alarm fatigue because you can silence the audible alarm with the tap of a finger.

The CMS-2000 communicates on its own subnet with the FMS-2000C and HMS-1655 family of controllers.

Note: The CMS-2000 does not monitor the FMS-2000M Critical Environment Monitor.

Features and benefits

Table 1: Features and benefits

Features	Benefits
Communications	The CMS-2000 communicates on its own subnet with the FMS and HMS family of controllers. It does not monitor the FMS-2000M.
Visual alarm	360° Safety Halo illuminated edge which helps you monitor spaces down long corridors
Audible alarm	Audible alarm that you can silence with the tap of a finger to reduce alarm fatigue
Intuitive UI design	Intuitive user interface for fast and easy setup
Display	Thin 0.58 in (14.73 mm), full color 5 in. (127 mm) diagonal, high definition (720 px x 1280 px) touch screen display that works with rubber, nitrile and latex gloves
Non-volatile memory	Retains user settings in case of a power outage
Password protection	Two access levels to prevent unauthorized access
Multilingual	Offers a user interface that is translated to 18 languages
Inbuilt tutorial video	End user demonstration video accessible from the QR code on the display

Applications

- Airborne infection isolation rooms - negative pressure
- Protective environment isolation rooms - positive pressure
- Airborne infection isolation rooms and protective environment room with an anteroom
- Operating rooms
- Compounding pharmacies
- Intensive care units
- Laboratories and vivariums
- Burn units
- Bronchoscopy suites
- Mortuary preparation rooms and autopsy rooms
- Data centers
- Laundry areas, food prep, construction

■ Installing the CMS-2000 Thin Mount display for a retrofit application

Ensure you mount the CMS-2000 in landscape orientation. Use the retrofit ring in applications where there is an existing wall. You can order the retrofit ring separately, use part number RTROMT-2.

Before you begin, make sure you have the following tools:

- Drywall saw or an oscillating tool with a drywall saw blade
 - Drill and a 7/16 in. drill bit
 - #2 Phillips head screwdriver
 - 1/16 in. hex wrench
1. Choose the location where you want to place the CMS-2000 monitor.
Note: You can only install the CMS-2000 in landscape orientation.
 2. Place the retrofit ring in the location that you want and keep the ring level.
 3. Mark the screw holes and the corners of the rectangular section.
 4. Use a drywall saw or oscillating tool to cut out the entire rectangular section inside the marked opening and drill the screw holes.
 5. Pull the pre-wired 4-conductor interface cable with the 4-pin terminal block for power, and the 3-pin terminal block for the RS-485 subnet coms through the retrofit ring.
 6. If the 2-conductor power cable terminates at the monitor, pull the 2-conductor power cable through the retrofit ring.
 7. Diagonally insert the retrofit ring through the hole in the wall. Position to fit the hole from the inside. Ensure that the four tabs make contact with the inside of the opening and then pull the retrofit ring flush against the inside of the wall.
 8. Remove the display's mounting bracket from the back of the display by removing the hex screw.
 9. Use the four provided mounting screws to attach the monitor's mounting bracket to the retrofit ring. Use a #2 Phillips head screwdriver to secure both the box and the bracket.
Note: To avoid warping the mounting bracket, do not over-tighten the screws.
 10. Connect the wires to the back of the monitor.
 11. Align the two slots on top of the monitor with the tabs on the bracket, then swing the monitor towards the wall so that the single tab on the bracket slots into the back of the monitor.
 12. When the monitor sits flush against the wall, insert the hex screw into the hole on the side or bottom of the monitor's housing. Use a 1/16 in. hex wrench to drive the screw into the monitor until it engages with the tab.

After you mount the CMS-2000 monitor, apply power to the monitor. The initial splash screen displays the Johnson Controls® logo and the 360° Safety Halo bezel lights up green to represent the current system status.

Figure 1: Retrofit ring

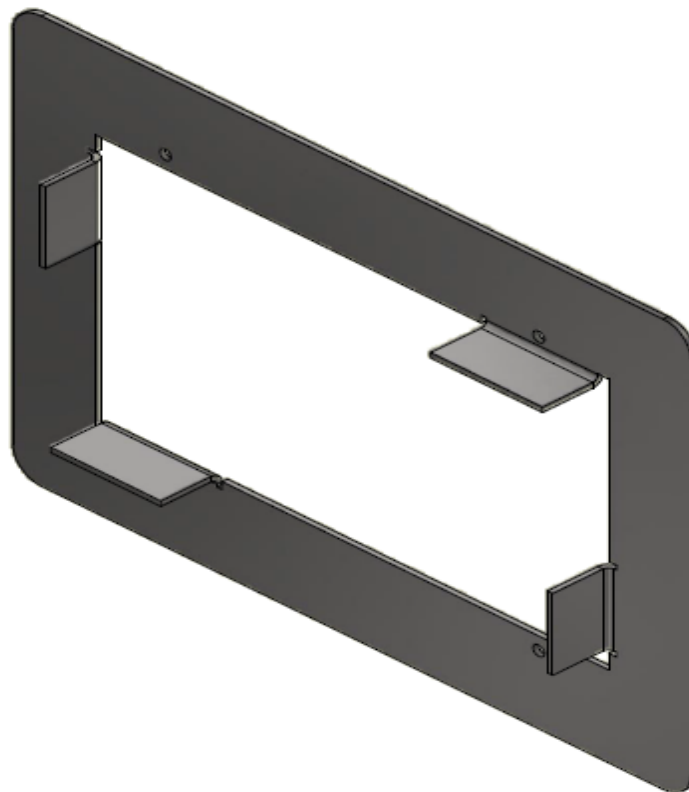

Figure 2: CMS-2000 Central Monitoring Station retrofit ring installation components

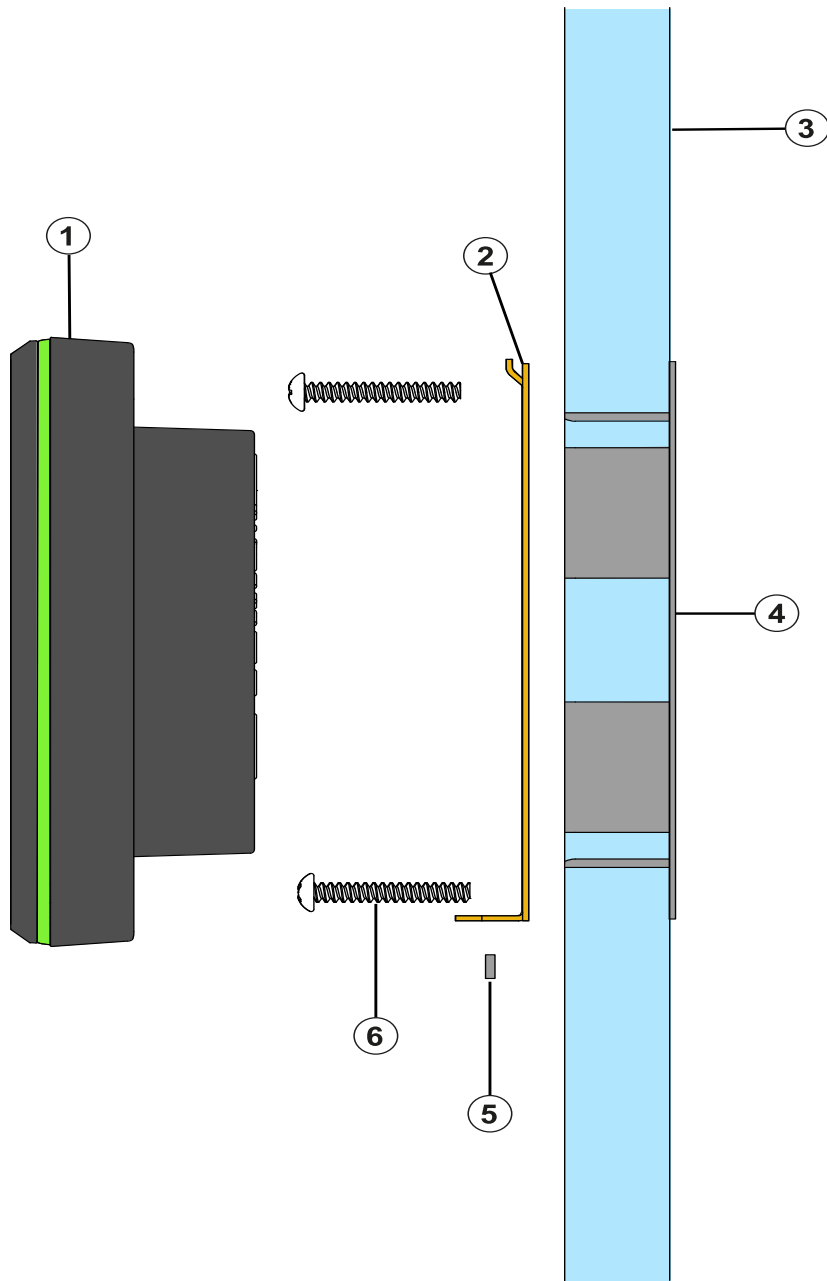
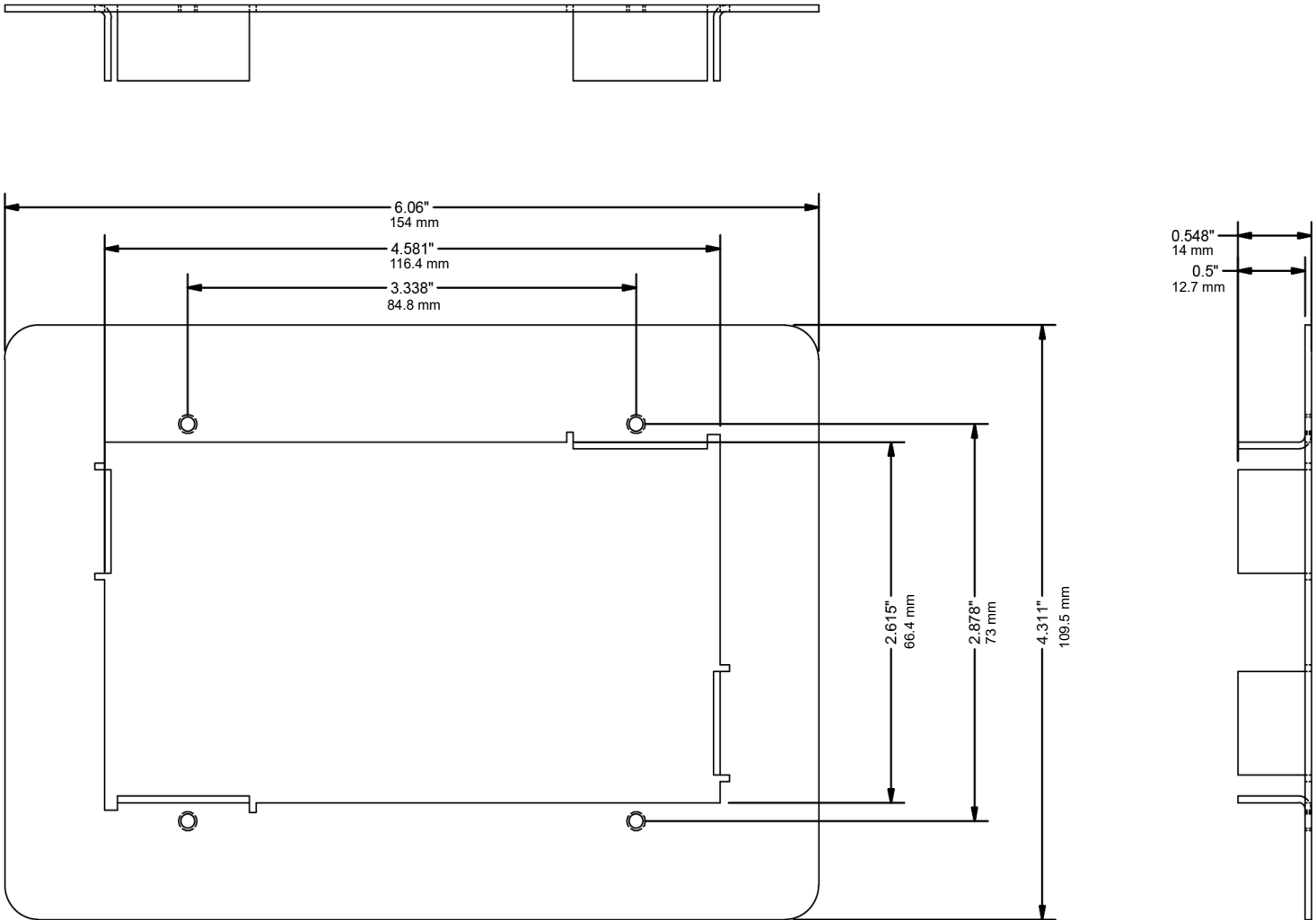

Table 2

Item	Component
1	CMS-2000 Central Monitoring Station
2	Monitor bracket
3	Wall
4	Retrofit ring
5	Mounting screw
6	Hex screw

Figure 3: Retrofit application dimensions



■ Installing the CMS-2000 Thin Mount display for a new application

Use the rough-in box for new construction applications when the walls have not yet been installed. You can order the rough-in box separately, use part number RFINMT-2.

Before you begin, make sure you have the following tools:

- Drywall saw or an oscillating tool with a drywall saw blade
 - Drill and a 7/16 in. drill bit
 - #2 Phillips head screwdriver
 - 1/16 in. hex wrench
1. Choose the location where you want to place the CMS-2000 monitor.

Note: You can only install the CMS-2000 in landscape orientation
 2. Mount the rough-in box to the side of a stud. Make sure the front surface is flush, or slightly recessed, to fit with the drywall surface that you install later.
 3. Pull the pre-wired 4-conductor interface cable with the 4-pin terminal block for power, and the 3-pin terminal block for the RS-485 subnet coms through the opening in the rough-in box.
 4. If the 2-conductor power cable terminates at the monitor, pull the 2-conductor power cable through the opening in the rough-in box.
 5. Install the drywall. Make sure that the mounting surface is flush with the finished surface of the drywall, and the opening fits precisely with the rough-in box.
 6. To remove the display's mounting bracket from the back of the display, remove the hex screw.
 7. Align the monitor's mounting bracket to the four screw holes on the mounting tabs of the rough-in box. Use a #2 Phillips head screwdriver to secure the bracket with the screws provided. Ensure the bracket is level.

Note: To avoid warping the mounting bracket, do not over-tighten the screws.
 8. Connect the wires to the back of the monitor.
 9. Align the two slots on the back of the monitor with the tabs on the bracket and swing the monitor towards the wall so that the single tab on the bracket slots into the back of the monitor.
 10. Insert the hex screw into the hole in the monitor's housing when the monitor sits flush against the wall. Use a 1/16 in. hex wrench to drive the screw into the monitor until it engages with the tab on the bracket.

After you mount the CMS-2000 monitor, apply power to the monitor. The initial splash screen displays the Johnson Controls logo and the 360° Safety Halo bezel is green to represent the current system status.

Figure 4: Rough-in box

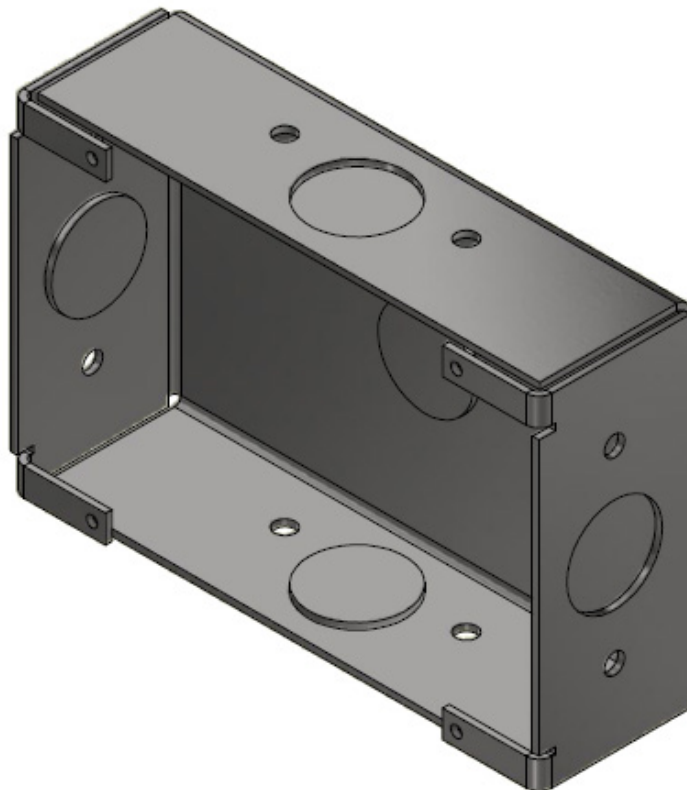

Figure 5: CMS-2000 Central Monitoring Station rough-in installation components

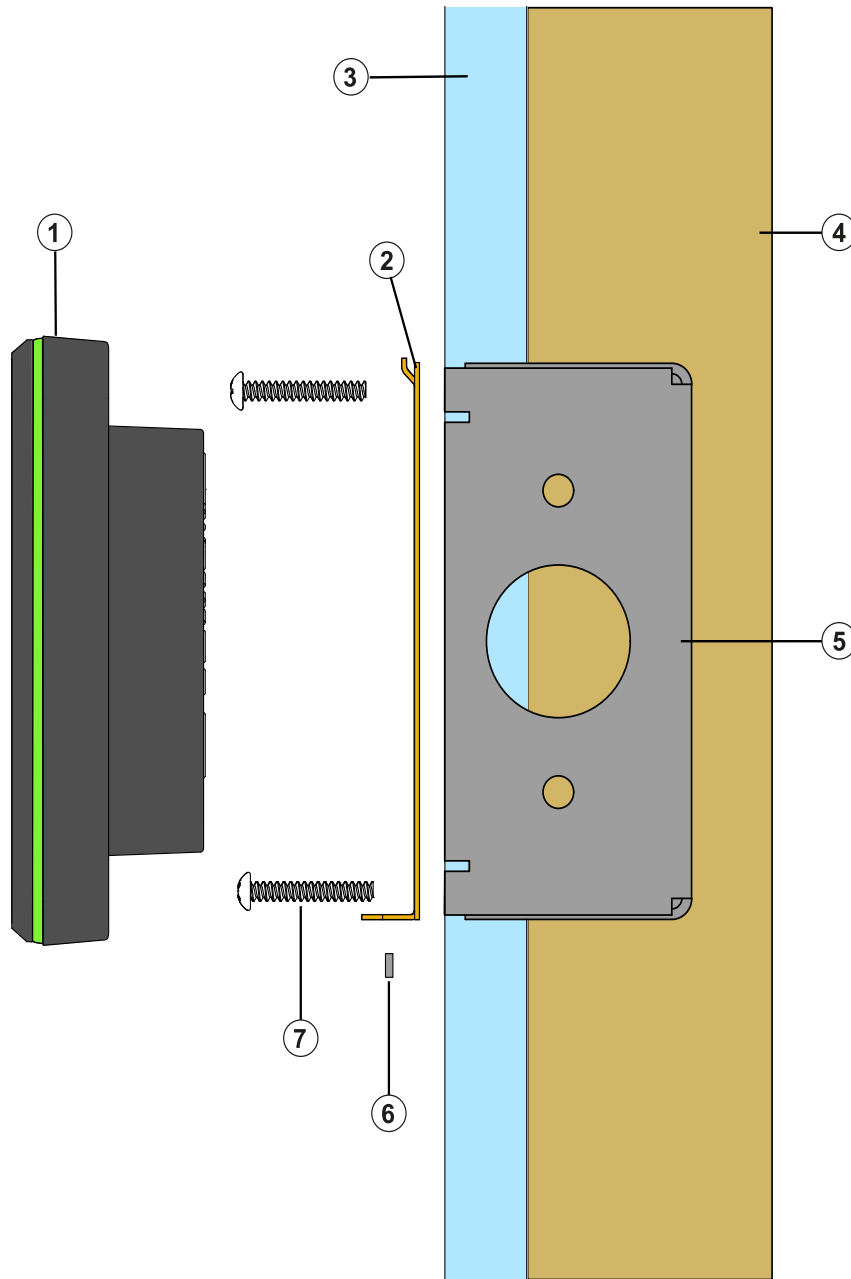
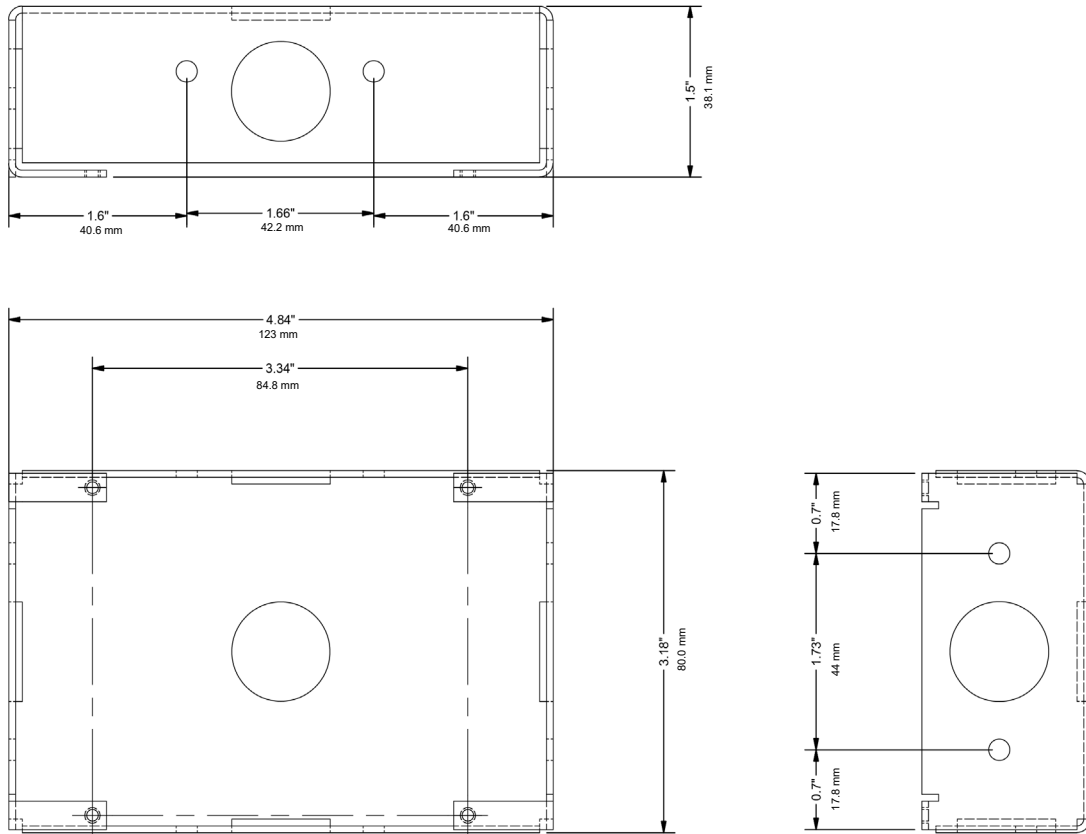

Table 3

Item	Component
1	CMS-2000 Central Monitoring Station
2	Monitor bracket
3	Wall
4	Stud
5	Rough-in box
6	Mounting screw
7	Hex screw

Figure 6: Rough-in box dimensions



■ Display module settings configuration

Figure 7: DIP switch run and demo modes

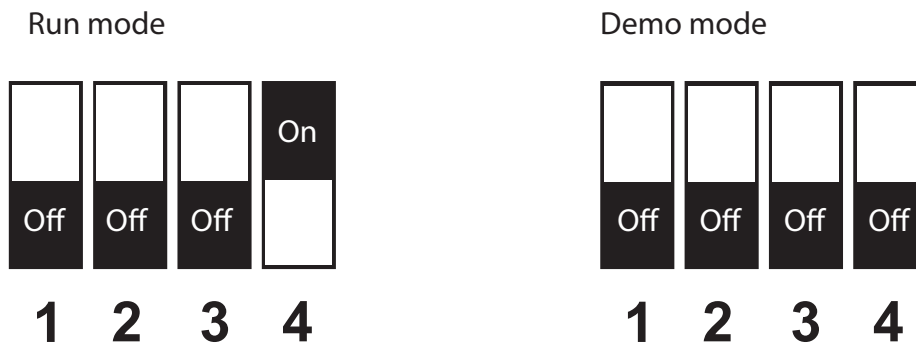

Note: Demo mode is a test display for demonstration purposes. You do not need to connect the CMS-2000 to the FMS-2000C or the HMS-1655 to use demo mode.

Table 4: Monitor DIP switch configurations for the operating mode

CMS-2000 DIP switch position	Run mode	Demo mode
1	Off	Off
2	Off	Off
3	Off	Off
4	On	Off

System diagram

In the following figure, you can see an overview of how the system operates with all the different devices.

Figure 8: System diagram

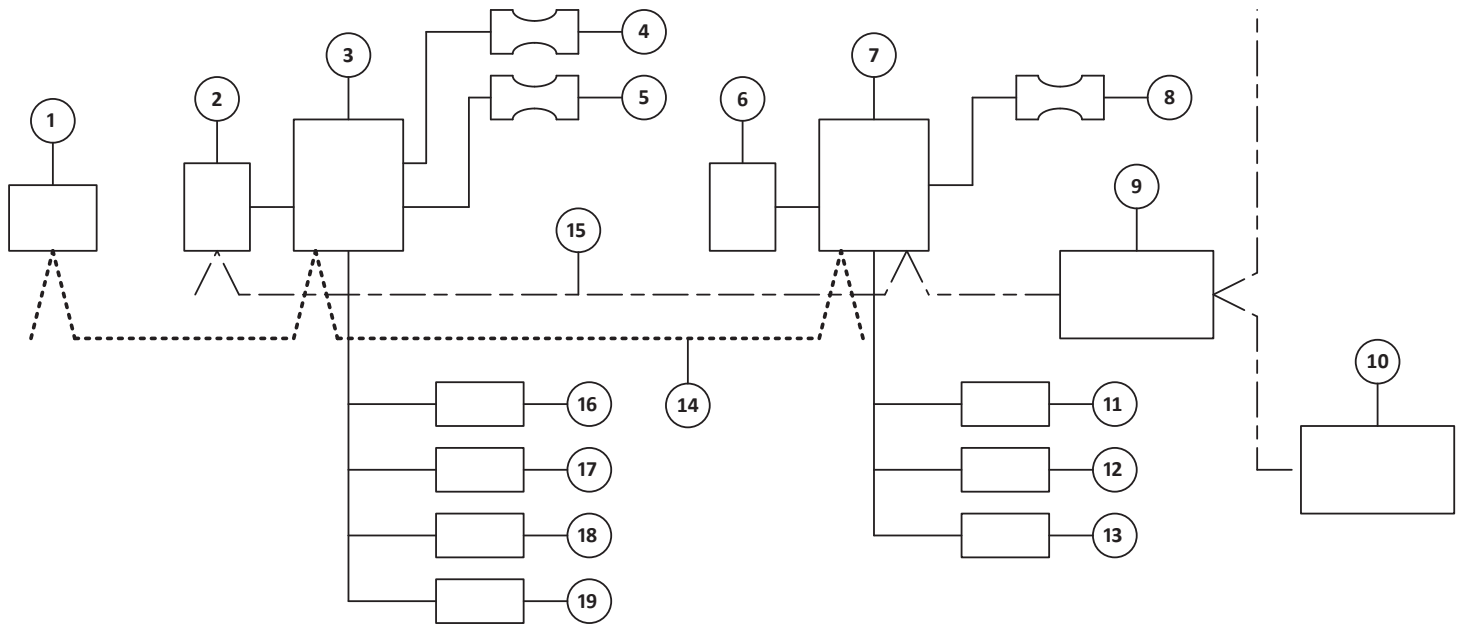

Table 5

Callout	Description
1	CMS-2000 display
2	FMS-2000C display
3	FMS-2000C controller
4	Supply valve
5	Exhaust valve
6	HMS-1655 display
7	HMS-1655 controller
8	Fume hood exhaust valve
9	Supervisory device
10	Building automation system (BAS)
11	Sash sensor
12	Sidewall sensor
13	Occupancy sensor
14	Subnet
15	BACnet
16	Pressure sensor
17	Temperature sensor
18	Humidity sensor
19	CO ₂ sensor

■ Wiring the CMS-2000 to the nearest FMS-2000C or HMS-1655 Controller

Identify the controller closest to the installed CMS-2000. Connect the CMS-2000 to the SUBNET terminal on the backplane of the controller. If there are multiple FMS-2000C or HMS-1655 controller units, daisy chain the SUBNET on the backplanes. For more information, see Figure 9.

Warning: The electrical connections to the CMS-2000 are made through convenient terminal block connectors. All wiring must conform to local regulations and to the National Electrical Code (NEC). Precautions must be taken to avoid running communications wiring in the same conduit as line voltage or other conductors that supply highly inductive loads such as generators, motors, solenoids, contactors, and other sources of induced noise. Use 22 AWG or larger for all electrical wiring terminations.

Figure 9: Daisy chain of FMS and/or HMS controllers

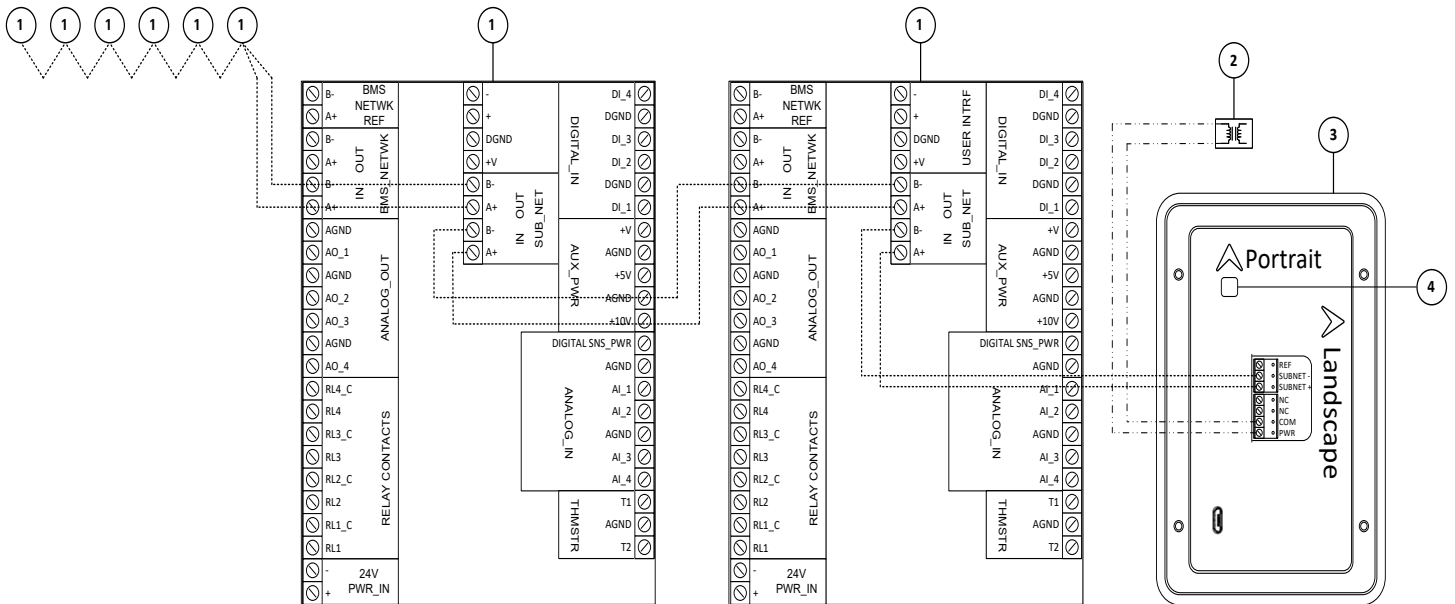





Table 6

Callouts	Description
1	Daisy chained FMS or HMS controllers
2	24 VAC transformer
3	CMS-2000 display
4	DIP switches

■ Technical specifications

Table 7: Technical specifications

Specification	Description	
Intended use	Indoor use	
Overvoltage category	II	
Monitoring capability	Up to eight FMS-2000C Critical Environment Controllers or HMS-1655 Fume Hood Controllers.	
Operating temperature	32°F to 104°F (0°C to 40°C)	
Operating humidity	10% to 95% relative humidity, non-condensing	
Mounting	Thin mount for shallow wall cavities	
Alarm indication	Audible and visual 360° Safety Halo illuminated edge	
Alarm silence	Touchscreen, auto-reset	
Password protection	Two access levels to prevent unauthorized access	
Power requirement	24 VAC (nominal, 21.6 VAC minimum/26.4 VAC maximum), 50/60 Hz 30 VA power supply, Class 2, Limited Energy, LPS isolated power supply, or minimum power 30 VA transformer.	
Power consumption	24 VA maximum	
Pollution degree	2	
Display resolution	720 pixels x 1280 pixels	
Pluggable screw terminal blocks	18 AWG to 22 AWG (1 mm to 0.6 mm diameter)	
Display dimensions (height x width x depth)	5.3 in. x 3.5 in. x 1.17 in. (134.62 mm x 88.9 mm x 29.72 mm)	
Mounted depth	Thin mount: 0.58 in (14.73 mm)	
Compliance   	United States	UL Listed (E515759) to UL 61010-1; FCC 47CFR Part 15
	Canada	cUL Listed (E515759) to CAN/CSA C22.2 NO. 61010-1; ICES-003
	Europe (CE)	Low Voltage Directive [2014/35/EU] per EN 61010-1 EMC Directive [2014/30/EU] per EN 61326-1 + EN 55011
	United Kingdom (UKCA)	Electrical Equipment (Safety) Regulations per EN 61010-1 EMC Regulations per EN 61326-1 + EN 55011
	International Standards	Product fulfills the requirements of IEC 61010-1 as recognized by national or regional authorities.

■ Mounting hardware

The CMS-2000 Thin mount requires one of the following mounting hardware for installation:

Table 8: Mounting hardware

Ordering code	Description
RFINMT-2	Rough-in box for new constructions with uninstalled walls
RTROMT-2	Retrofit ring with walls already installed

■ Cleaning the display

IMPORTANT:

- Do not apply cleaner directly to the touch panel surface. If cleaner spills onto the touch panel, soak up the cleaner immediately with an absorbent cloth.
- Do not use cleaner that is either acidic or alkaline. Use neutral pH cleaner.
- Do not use organic chemicals such as paint thinner, acetone, toluene, xylene, propyl or isopropyl alcohol, or kerosene.

IMPORTANT :

- N'appliquez pas de nettoyant directement sur la surface du panneau tactile. Si du nettoyant pénètre dans le panneau tactile, essuyez immédiatement le nettoyant à l'aide d'un chiffon absorbant.
- N'utilisez aucun nettoyant qui est acide ou alcalin. Utilisez un nettoyant dont le pH est neutre.
- N'utilisez pas de produits chimiques organiques comme le diluant pour peinture, l'acétone, le toluène, le xylène, l'alcool propylique ou isopropylique, ou le kérosène.

To clean the display, complete the following steps:

1. Use a dry or lightly dampened microfiber cloth with a mild cleaner or ethanol. Make sure the cloth is only lightly dampened, not wet.
2. Wipe the surface gently. If there is a directional surface texture, wipe in the same direction as the texture.

■ North American Emissions Compliance

United States

This equipment has been tested and found to comply with the limits for a Class A digital device pursuant to Part 15 of the FCC Rules. These limits are designed to provide reasonable protection against harmful interference when this equipment is operated in a commercial environment. This equipment generates, uses, and can radiate radio frequency energy and, if not installed and used in accordance with the instruction manual, may cause harmful interference to radio communications. Operation of this equipment in a residential area may cause harmful interference, in which case users will be required to correct the interference at their own expense.

Canada

This Class (A) digital apparatus meets all the requirements of the Canadian Interference-Causing Equipment Regulations.
Cet appareil numérique de la Classe (A) respecte toutes les exigences du Règlement sur le matériel brouilleur du Canada.

■ Repair information

If the CMS-2000 Central Monitoring Station fails to operate within its specifications, replace the unit. For a replacement CMS-2000, contact the nearest Johnson Controls® representative.

Product warranty

This product is covered by a limited warranty, details of which can be found at www.johnsoncontrols.com/buildingswarranty.

Software terms

Use of the software that is in (or constitutes) this product, or access to the cloud, or hosted services applicable to this product, if any, is subject to applicable end-user license, open-source software information and other terms set forth at www.johnsoncontrols.com/techterms. Your use of this product constitutes an agreement to such terms.

Patents

Patents: <https://jciapat.com>

Single point of contact

APAC	Europe	NA/SA	UK
JOHNSON CONTROLS C/O CONTROLS PRODUCT MANAGEMENT NO. 32 CHANGJIANG RD NEW DISTRICT WUXI JIANGSU PROVINCE 214028 - CHINA	JOHNSON CONTROLS WESTENDHOF 3 45143 ESSEN GERMANY	JOHNSON CONTROLS 507 E MICHIGAN ST MILWAUKEE WI 53202 USA	JOHNSON CONTROLS TYCO PARK GRIMSHAW LANE MANCHESTER M40 2WL UNITED KINGDOM

Contact information

Contact your local branch office: www.johnsoncontrols.com/locations

Contact Johnson Controls: www.johnsoncontrols.com/contact-us

Contact Technical Support:

- For the United States, 800-524-1330.
- For all other countries, contact your local technical support group.