

MR Series Refrigeration Temperature Controls

The MR Series Controls are versatile, microprocessor-based, multifunction, programmable temperature controls. Depending on the model chosen, the MR Series Controls can also manage alarm, defrost cycle (active or passive defrost), and evaporator fan functions.

The MR Series Controls have large red LED displays. These compact controls are available in panel mount and DIN rail mount varieties. The MR Series Controls use the A99B temperature sensors, which allow remote mounting of the display unit.



Figure 1: MR4 DIN Rail Mount and Panel Mount Refrigeration Temperature Controls

Features and Benefits	
<input type="checkbox"/> Programmable Functions	Allows adjustment of control settings to meet application needs
<input type="checkbox"/> Alarm Management Functions	Provides alarm codes and an alarm output relay that can be used to trigger a remote alarm or dial-out modem
<input type="checkbox"/> Easily Readable LED Display	Displays temperature and other functions quickly and clearly
<input type="checkbox"/> Programming Button Lockout	Allows user to disable programming buttons and deter accidental or unauthorized changes
<input type="checkbox"/> Accurate, Interchangeable Temperature Sensor	Provides accurate control performance with up to 300 feet of wiring (An adjustable temperature offset is provided for longer wiring.)
<input type="checkbox"/> Self-Test Procedure	Checks control operation by cycling all outputs and testing all LEDs

Applications

IMPORTANT: All MR Series Controls are designed for use **only** as operating controls. Where an operating control failure would result in personal injury or loss of property, it is the responsibility of the installer to add devices (safety, limit controls) or systems (alarm, supervisory systems) that protect against, or warn of, control failure.

All MR Series Controls perform temperature and alarm management. Some models have additional capabilities.

MR1 Series Controls

The MR1 Series provides temperature and alarm management functions. It can replace a temperature control and digital temperature readout.

MR2 Series Controls

The MR2 Series provides temperature, alarm, and defrost cycle management. The MR2 control performs defrost cycle management using time-based, passive, off-cycle defrost in refrigeration units. It can replace a temperature control, a digital temperature readout, and a defrost timer.

MR4 Series Controls

The MR4 Series provides temperature, alarm, defrost, and evaporator fan management. The MR4 Series provides defrost cycle management with hot gas or electric heat defrost and defrost termination based on time or temperature. The MR4 Series consolidates the functions of a temperature control, a digital temperature readout, a defrost cycle timer, and a defrost termination device.

Typical applications include the following:

Table 1: Sample Applications

MR1	MR2	MR4	Application
✓			Cooling tower pump control
✓			Space and return air temperature control
✓	✓	✓	Convenience store coolers
		✓	Convenience store freezers
	✓	✓	Supermarket display cases for produce
	✓	✓	Reach-in coolers
	✓	✓	Walk-in coolers
	✓	✓	Freezers or coolers with passive defrost, time-based termination
		✓	Freezers with hot gas defrost (temperature or time-based termination)
		✓	Freezers with electrical defrost (temperature or time-based termination)

All MR Series models use the Johnson Controls/PENN A99BB-200C temperature sensor. Refer to a specific MR Series Control model installation bulletin for the necessary information on installation, use, and servicing.

Functions

The MR Series Controls offer a variety of refrigeration and alarm management functions, which are listed below. Not all of these functions are available on every model.

Refer to the specific model MR installation bulletin or contact your authorized Johnson Controls/PENN distributor or sales representative for functions, setting ranges, switching, and ratings included on specific models.

Temperature Management

Setpoint is the desired temperature (°F or °C) programmed by the user. Many other function settings are relative to setpoint temperature, which is measured at the process temperature sensor.

When **setpoint** is reached, the temperature control output contacts open, stopping the refrigeration On cycle.

Differential (or **Hysteresis**) establishes the difference (F° or C°) between **setpoint** and the temperature at which the temperature control output contacts close, beginning the refrigeration On cycle.

High and Low Setpoint Stops are temperature setpoints (°F or °C) that define how high and low **setpoint** may be adjusted. Setpoint stops deter unauthorized or accidental over-adjustment of **setpoint**.

Anti-short Cycle Delay establishes the minimum time (minutes) between the start of one On cycle and the start of the next On cycle.

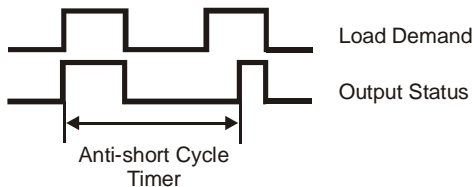

Figure 2: Anti-short Cycle Delay

Deep Freezing Time overrides **setpoint** temperature control and closes the temperature control output contacts for a user-defined time (minutes). Typically, this function is used to run the compressor continuously during periods of high refrigeration load to bring the sensed temperature below **setpoint** and deep freeze the product.

Sensor Failure Operation allows user to select how the temperature control output contacts operate in the event of a sensor related failure. The MR Series Control remains in the selected failure operation mode until the failure is remedied.

There are three options:

- temperature control contact is always closed
- temperature control contact is always open
- temperature control contact is time cycled based on the average On and Off times of the last four cycles

Temperature Sensor Offset allows the user to compensate for temperature differences between actual and displayed temperature, such as those experienced when using long sensor leads.

Temperature Units allows the user to select either the Fahrenheit or Celsius temperature scale.

Display Refresh Rate establishes the time delay (seconds) between updates of the temperature display.

Alarm Management

High Temperature Alarm establishes the temperature relative to the **setpoint** (F° or C°) at which the control goes into a high temperature alarm condition.

Low Temperature Alarm establishes the temperature relative to **setpoint** (F° or C°) at which the control goes into a low temperature alarm condition.

Alarm Differential establishes the difference (F° or C°) between the temperature at which the alarm contacts are closed and the temperature at which they are opened.

Example (cooling):

Setpoint = 40°F

High Temperature Alarm = 15F°

Alarm Differential = 2F°

When the cooler temperature exceeds $40+15=55^{\circ}\text{F}$ for a time greater than the **Alarm Time Delay** setting, the alarm message is displayed; however, it will not reset until the temperature drops below $40+15-2 = 53^{\circ}\text{F}$.

Alarm Time Delay establishes the time delay (minutes) between reaching an alarm condition (high or low temperature) and closing the alarm contacts. This function reduces alarm oscillation and nuisance alarms caused by temperature changes that temporarily exceed alarm setpoints.

Temperature alarm conditions are disregarded by the MR Series Control during the first 20 minutes after power up, during the defrost cycle, and for 20 minutes after the end of the defrost cycle.

Defrost Cycle Management

Defrost Type allows the user to select either electric heater or hot gas defrost operation, depending on the application.

Defrost End Mode allows the user to select defrost termination based on either time or temperature. If temperature is selected, defrost termination will occur after the time selected in **maximum defrost duration**, even if the selected temperature is not achieved.

Defrost Termination Temperature establishes the temperature setpoint (°F or °C) that ends the defrost cycle, when the user has selected temperature for the **defrost end mode**.

Defrost Interval establishes the time (hours) between defrost cycles. When the defrost interval is 1 hour, the **maximum defrost duration** cannot be set at more than 40 minutes.

Maximum Defrost Duration establishes the maximum time (minutes) of the defrost cycle. A setting of 0 disables the defrost cycle.

Dripping Time establishes the time (minutes) that water is allowed to drain away from the evaporator coil after defrost termination and before the compressor and evaporator fans are started for the next freeze cycle.

First Defrost After Power Up establishes the time delay (hours) until the first defrost cycle after starting or restarting the refrigeration system. If this function is turned Off, the first defrost occurs after **defrost interval**.

Display During Defrost defines the temperature (°F or °C) displayed during the defrost cycle. The user may select to display either **setpoint** or the sensed temperature just prior to the start of the defrost cycle.

Display After Defrost establishes the time delay (minutes), after defrost termination, before the control displays the sensed temperature.

Evaporator Fan Management

Fan Operation allows the user to select how the fan operates – either continuously or only when the compressor is running. (The evaporator fan is always switched Off during the defrost cycle.)

Fan Start Up Delay establishes the maximum time delay (minutes) after defrost termination, before the fan contacts close and restart the fan (even if **fan start temperature** has not been reached.)

Fan Start Temperature establishes the evaporator temperature setpoint (°F or °C) at which the fan contacts close and restart the evaporator fan after defrost termination. If the start temperature is not reached, the fan is switched On after the time delay set in **fan start up delay**.

Binary Input

Binary Input Function allows the user to select how the binary input will activate the control output or alarm contacts. The user can select to disengage this function. The user can also select one of three options if the binary input contact is open for a time longer than that set through the **binary input time delay**:

- The temperature control, defrost, and fan outputs are switched Off, an alarm message is displayed, and the alarm output is switched On. This could be used with a high-pressure switch to warn of system malfunction.
- An alarm message is displayed and the alarm output is switched On.
- An alarm message is displayed, the alarm output is switched On, the fan output is switched Off, and high and low temperature alarms are disabled. This could be used with a door switch to warn of a door that remains open.

Binary Input Time Delay establishes the time delay (minutes) between binary input signal and control output response to the binary signal.

Table 2: Functions and Setting Ranges

MR1	MR2	MR4	Function	Setting Range
✓	✓	✓	Setpoint	-40 to 158°F (-40 to 70°C)
✓	✓	✓	Hysteresis (Differential)	1 to 9°F (1 to 9°C)
✓	✓	✓	High Setpoint Stop	Low Setpoint Stop to 158°F (70°C)
✓	✓	✓	Low Setpoint Stop	-40°F (-40°C) to High Setpoint Stop
✓	✓	✓	Anti-short Cycle Delay	0 to 9 minutes
✓	✓	✓	Deep Freezing Time	0 to 99 minutes
✓	✓	✓	Sensor Failure Operation	0 = compressor On 1 = compressor Off 2 = based on last four cycles
✓	✓	✓	Temperature Sensor Offset	-20 to 20°F (-20 to 20°C)
✓	✓	✓	Temperature Units Used	0 = °C 1 = °F
✓	✓	✓	Display Refresh Rate	1 to 99 seconds
✓	✓	✓	High Temperature Alarm	0 to 50°F (0 to 50°C)
✓	✓	✓	Low Temperature Alarm	-50 to 0°F (-50 to 0°C)
✓	✓	✓	Alarm Differential	1 to 9°F (1 to 9°C)
✓	✓	✓	Alarm Time Delay	0 to 99 minutes
	✓	✓	Defrost Interval	1 to 99 hours
	✓	✓	Maximum Defrost Duration	0 to 99 minutes
		✓	Dripping Time	0 to 99 minutes
	✓	✓	First Defrost After Power Up	Off, 0 to 99 minutes
	✓	✓	Display During Defrost	0 = last reading 1 = setpoint
	✓	✓	Display Delay After Defrost	1 to 99 minutes
	✓	✓	Binary Input Function	0 = none 1 = compressor Off, alarm On 2 = alarm On 3 = fan Off, alarm On
	✓	✓	Binary Input Time Delay	0 to 99 minutes
		✓	Defrost Type	0 = electrical 1 = hot gas
		✓	Defrost End Mode	0 = time 1 = temperature
		✓	Defrost Termination Temperature	32 to 68°F (0 to 20°C)
		✓	Fan Operating Function	0 = parallel with compressor 1 = always On
		✓	Fan Start Up Delay (After Defrost)	0 to 99 minutes
		✓	Fan Start Temperature After Defrost End	-22 to 41°F (-30 to 5°C)

Display Panel

The display has three LED digits and a minus (-) indication. It displays a temperature range from -40 to 158°F (-40 to 70°C) in increments of 1°F or °C.

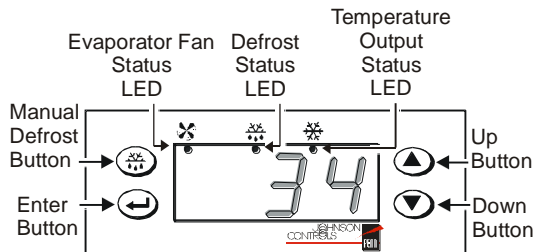

Figure 3: Front Display Panel for Panel Mount MR4 Series Control

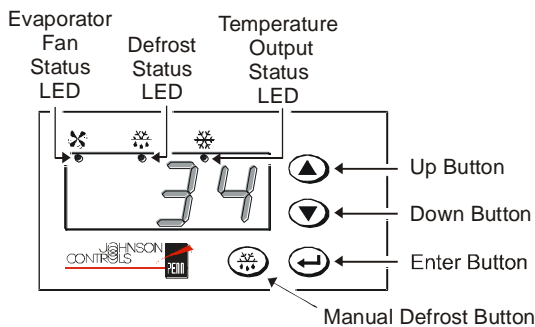

Figure 4: Front Display Panel for DIN Rail Mount MR4 Series Control

Depending on the model, the front display panel may contain fewer status LEDs and/or buttons than shown here.

Alarm Codes

The MR Series Controls can display several alarm codes that are used to assist in troubleshooting control errors. Alarm codes exist for the following conditions:

- temperature sensor failure
- evaporator sensor failure
- high temperature alarm
- low temperature alarm
- program failure
- three binary input codes

Button Lockout

The buttons on the panel may be deactivated in order to deter accidental or unauthorized modifications.

Self-Test Procedure

The self-test procedure allows the user to verify that the LEDs and outputs of a unit are operating correctly before the control is put into service. The control must not be wired to any equipment other than input power when the self-test is initiated.

When the self-test is initiated, power is cycled to each of the relays, to the status LEDs, and then to the segments of the large LED display. The MR Series control shuts off after completing the self-test. To put the MR Series control back into normal operation, cycle power to the control.

MR1 Temperature Control

The MR1 Series provides temperature and alarm management functions. It replaces a temperature control and digital temperature readout. The alarm circuit requires a separate external power source (40 VDC, 100 mA maximum).

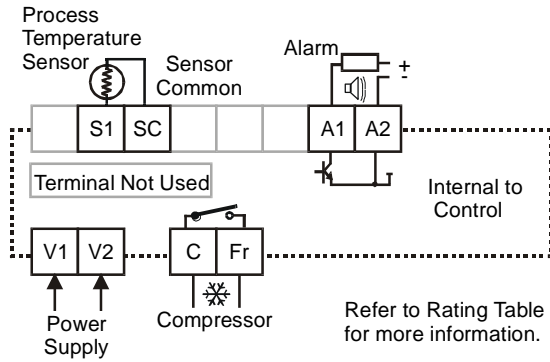

Figure 5: MR1 DIN Rail Control

Table 3: MR1 Ordering information

Product Code Number	Description
MR1DR24-11C	MR1 DIN Rail Mount Control, A99BB-200C sensor included Shipping Weight 0.75 lbs. (340 g)

Table 4: Rating Table

Rating Category	120 VAC	240 VAC	24 VDC
Horsepower	1/4	1/2	---
Full Load Amperes	5.8	4.9	---
Locked Rotor Amperes	34.8	29.4	---
Inductive (non-motor) Amperes	8	8	8
Pilot Duty VA	275	450	---

Alarm circuit transistor is 40 VDC, 100 mA maximum. Alarm requires separate power source. Power supply is 24 VAC.

Temperature Management Functions

- Setpoint
- Differential (Hysteresis)
- Low Setpoint Stop
- High Setpoint Stop
- Anti-short Cycle Delay
- Deep Freezing Time
- Sensor Failure Operation
- Temperature Sensor Offset
- Temperature Units Used
- Display Refresh Rate

Alarm Management Functions

- High Temperature Alarm
- Low Temperature Alarm
- Alarm Differential
- Alarm Time Delay

MR2 Temperature/Defrost Control

The MR2 Series provides temperature, alarm, and defrost cycle management. The MR2 control performs defrost cycle management using time-based, passive, off-cycle defrost in refrigeration units. It can replace a temperature control, a digital temperature readout, and a defrost timer. The alarm circuit requires a separate external power source.

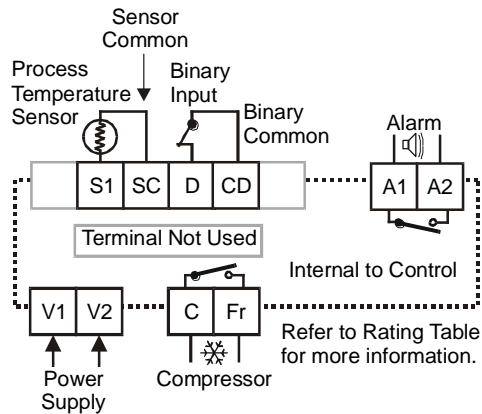

Figure 6: MR2 DIN Rail Control

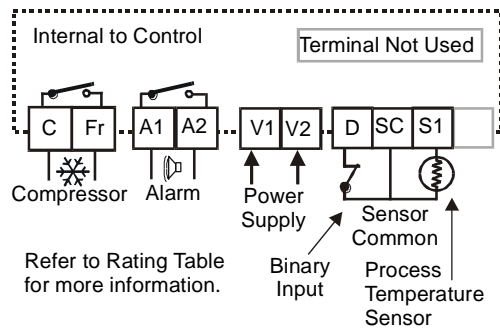

Figure 7: MR2 Panel Mount Control

Table 5: MR2 Ordering information

Product Code Number	Description
MR2PM24-11C	MR2 Panel Mount Control, A99BB-200C sensor included Shipping Weight 0.53 lbs. (240 g)
MR2DR24-11C	MR2 DIN Rail Control, A99BB-200C sensor included Shipping Weight 0.79 lbs. (360 g)

Table 6: Rating Table

Rating Category	120 VAC	240 VAC	24 VDC
Horsepower	1/4	1/2	---
Full Load Amperes	5.8	4.9	---
Locked Rotor Amperes	34.8	29.4	---
Inductive (non-motor) Amperes	8	8	8
Pilot Duty VA	275	450	---

Power supply is 24 VAC.

Alarm requires separate power source.

Temperature Management Functions

- Setpoint
- Differential (Hysteresis)
- Low Setpoint Stop
- High Setpoint Stop
- Anti-short Cycle Delay
- Deep Freezing Time
- Sensor Failure Operation
- Temperature Sensor Offset
- Temperature Units Used
- Display Refresh Rate

Alarm Management Functions

- High Temperature Alarm
- Low Temperature Alarm
- Alarm Differential
- Alarm Time Delay

Defrost Management Functions

- Defrost Interval
- Maximum Defrost Duration
- Dripping Time
- First Defrost After Power Up
- Display During Defrost
- Display Delay After Defrost

Binary Input Functions

- Input Function Selection
- Input Time Delay

MR4 Temperature/Defrost Control

The MR4 Series provides temperature, alarm, defrost, and evaporator fan management. The MR4 Series provides hot gas or electric heat defrost control, with defrost termination based on time or temperature. The MR4 Series consolidates the functions of a temperature control, a digital temperature readout, a defrost cycle timer, and a defrost termination device. The alarm circuit requires a separate external power source.

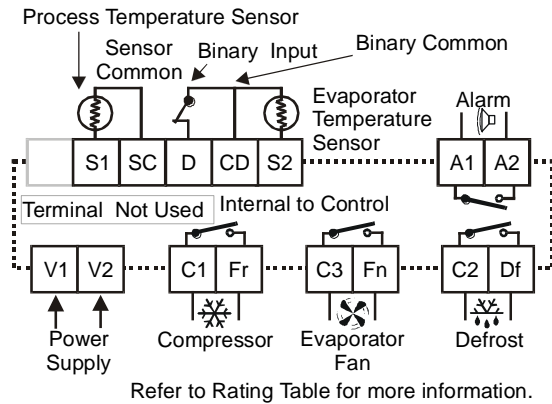

Figure 8: MR4 DIN Rail Control

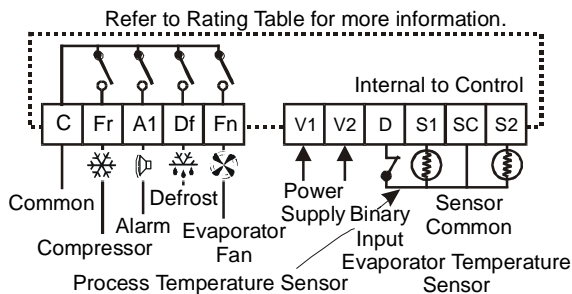

Figure 9: MR4 Panel Mount Control

Table 7: MR4 Ordering Information

Product Code Number	Description
MR4PM24-12C	MR4 Panel Mount Control, 2 A99BB-200C sensors included Shipping Weight 0.90 lbs. (410 g)
MR4DR24-12C	MR4 DIN Rail Mount Control, 2 A99BB-200C sensors included Shipping Weight 1.17 lbs. (530 g)

Table 8: Rating Table

Rating Category	120 VAC	240 VAC	24 VDC
Horsepower	1/4	1/2	---
Full Load Amperes	5.8	4.9	---
Locked Rotor Amperes	34.8	29.4	---
Inductive (non-motor) Amperes	8	8	8
Pilot Duty VA	275	450	---

Power supply is 24 VAC.

Relay outputs must not exceed 20 amperes total connected load.

Alarm requires separate power source.

Temperature Management Functions

- Setpoint
- Differential (Hysteresis)
- Low Setpoint Stop
- High Setpoint Stop
- Anti-short Cycle Delay
- Deep Freezing Time
- Sensor Failure Operation
- Temperature Sensor Offset
- Temperature Units Used
- Display Refresh Rate

Alarm Management Functions

- High Temperature Alarm
- Low Temperature Alarm
- Alarm Differential
- Alarm Time Delay

Defrost Management Functions

- Defrost Type
- Defrost End Mode
- Defrost Termination Temperature
- Defrost Interval
- Maximum Defrost Duration
- Dripping Time
- First Defrost After Power Up
- Display During Defrost
- Display Delay After Defrost
- Fan Operating Function
- Fan Start Up Delay (After Defrost)
- Fan Start Temperature After Defrost End

Binary Input Functions

- Input Function Selection
- Input Time Delay

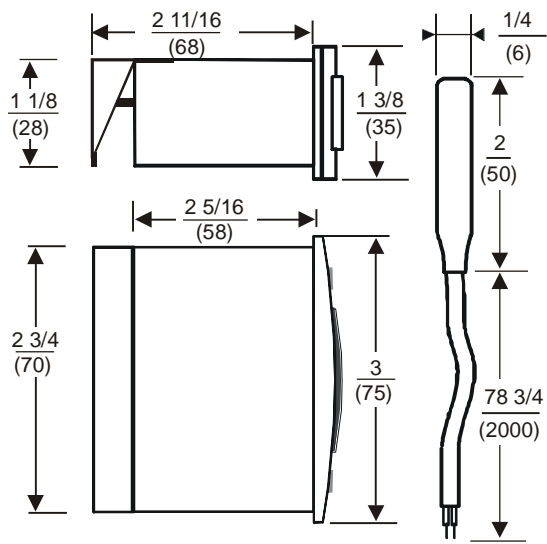

Figure 10: Panel Mount Control and A99 Sensor, in. (mm)

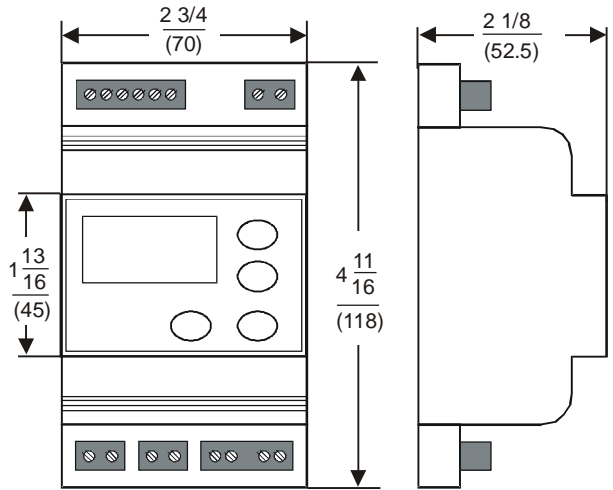

Figure 11: DIN Rail Control, in. (mm)

Table 9: A99 Temperature Sensor Ordering Information

Product Code Number	Temperature Range	Cable
A99BB-200C	-40 to 212°F (-40 to 100°C)	6 1/2 ft (2 m), Silicon sensor w/ PVC cable
A99BB-300C	-40 to 212°F (-40 to 100°C)	9 1/2 ft (3 m), Silicon sensor w/ PVC cable
A99BB-500C	-40 to 212°F (-40 to 100°C)	16 1/3 ft (5 m), Silicon sensor w/ PVC cable
A99BB-600C	-40 to 212°F (-40 to 100°C)	19 1/2 ft (6 m), Silicon sensor w/ PVC cable
A99BA-200C	-40 to 212°F (-40 to 100°C)	6 1/2 ft (2 m), Silicon sensor w/ shielded cable

Table 10: Electrical Ratings of Contacts

Rating Category	120 VAC	240 VAC	24 VDC
Horsepower	1/4	1/2	---
Full Load Amperes	5.8	4.9	---
Locked Rotor Amperes	34.8	29.4	---
Inductive (non-motor) Amperes	8	8	8
Pilot Duty VA	275	450	---

Relay outputs must not exceed 20 Amperes total connected load.

Open collector transistors on MR1 alarm circuit has a maximum rating of 40 VDC 100 mA.

Alarms require separate external power source.

Power supply is 24 VAC.

Specifications

Product	MR Series Refrigeration Temperature Controls
Power Requirements	3.7 VA @ 24 VAC, 50/60 Hz Class 2 (20-30 VAC)
Accuracy	±1.8°F (±1°C)
Ambient Conditions	Operating: 14 to 140°F (-10 to 60°C); 0 to 95% RH (non-condensing) Storage: -22 to 176°F (-30 to 80°C); 0 to 95% RH (non-condensing)
Dimensions (H x W x D)	Panel Mount: 1.38 x 2.95 x 2.68 in. (35 x 75 x 68 mm) DIN Rail Mount: 4.65 x 2.76 x 2.07 in. (118 x 70 x 52.5 mm)
Agency Listings	UL Recognized: File E194024, CCN XAPX2 Canadian UL Recognized: File E194024, CCN XAPX8 FCC Compliant per Class A Digital Device, Part 15 Canadian DOC Compliant per Class A, Radio Interference Regulations
Shipping Weight	Panel Mount: 0.33 lb. (150 g) without A99B-200C sensor, 0.46 lb. (209 g) with sensor DIN Rail Mount: 0.26 lb. (118 g) without A99B-200C sensor, 0.39 lb. (177 g) with sensor

The performance specifications are nominal and conform to acceptable industry standards. For application at conditions beyond these specifications, consult Johnson Controls/Penn Refrigeration Application Engineering at (414) 274-5535. Johnson Controls shall not be liable for damages resulting from misapplication or misuse of its products.



www.penncontrols.com

® Johnson Controls and PENN are registered trademarks of Johnson Controls in the United States of America and/or other countries. All other trademarks used herein are the property of their respective owners. © Copyright 2018 by Johnson Controls. All rights reserved.