



PRODUCT DIMENSIONS

AV50/AV60 Aluminum

AV50 - Horizontal Blades

AV60 - Vertical Blades

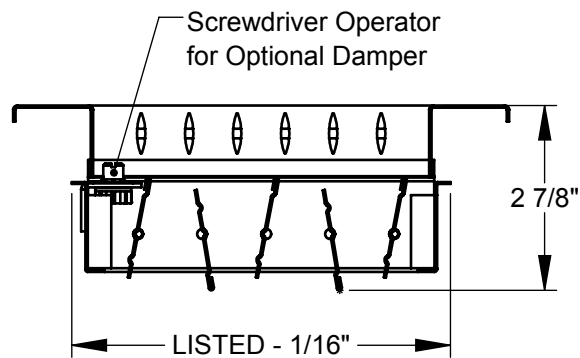
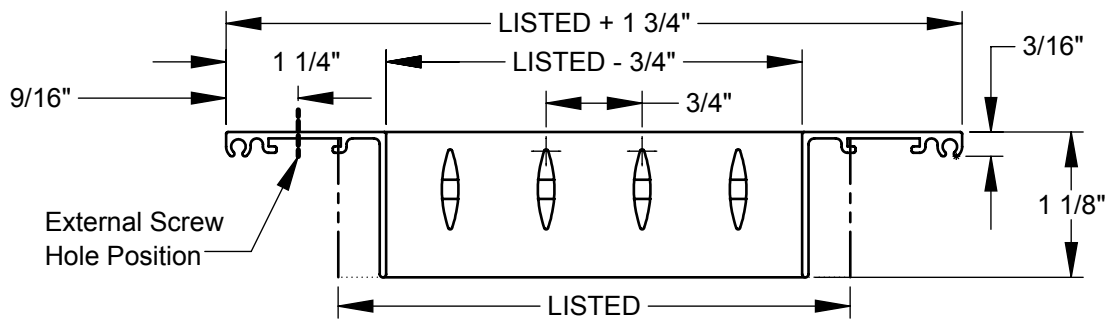
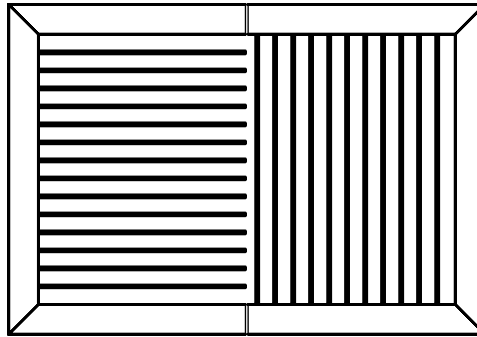



PRODUCT DIMENSIONS

AV54/AV64 Aluminum

AV54 - Horizontal Front Blades

AV64 - Vertical Front Blades

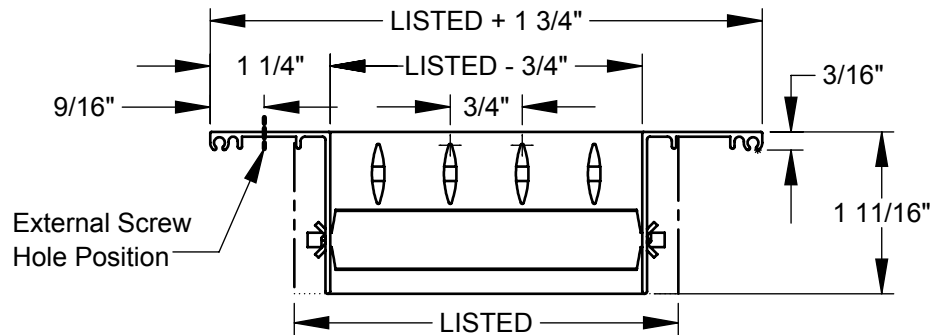
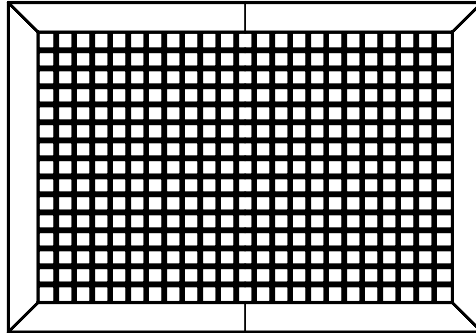

Screwdriver Operator for Optional Damper

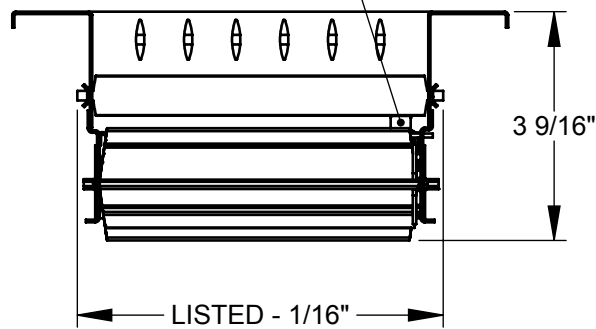



PRODUCT DIMENSIONS

AVS50/AVS60 Steel

AVS50 - Horizontal Blades

AVS60 - Vertical Blades

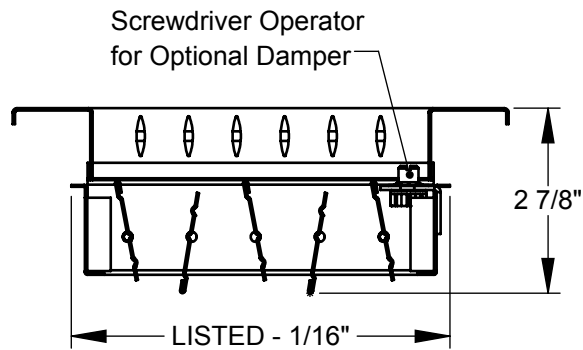
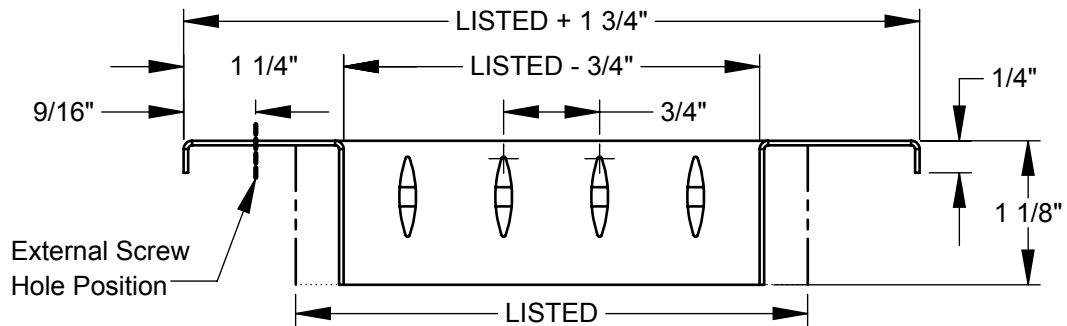
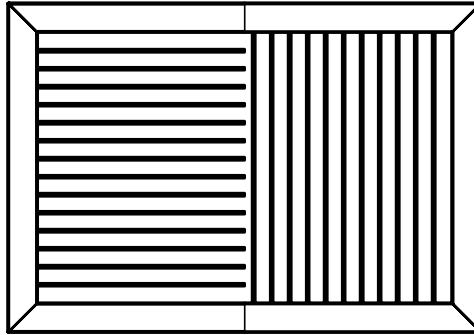



PRODUCT DIMENSIONS

AVS54/AVS64 Steel

AVS54 - Horizontal Front Blades

AVS64 - Vertical Front Blades

