

TOP VIEW

BOTTOM VIEW

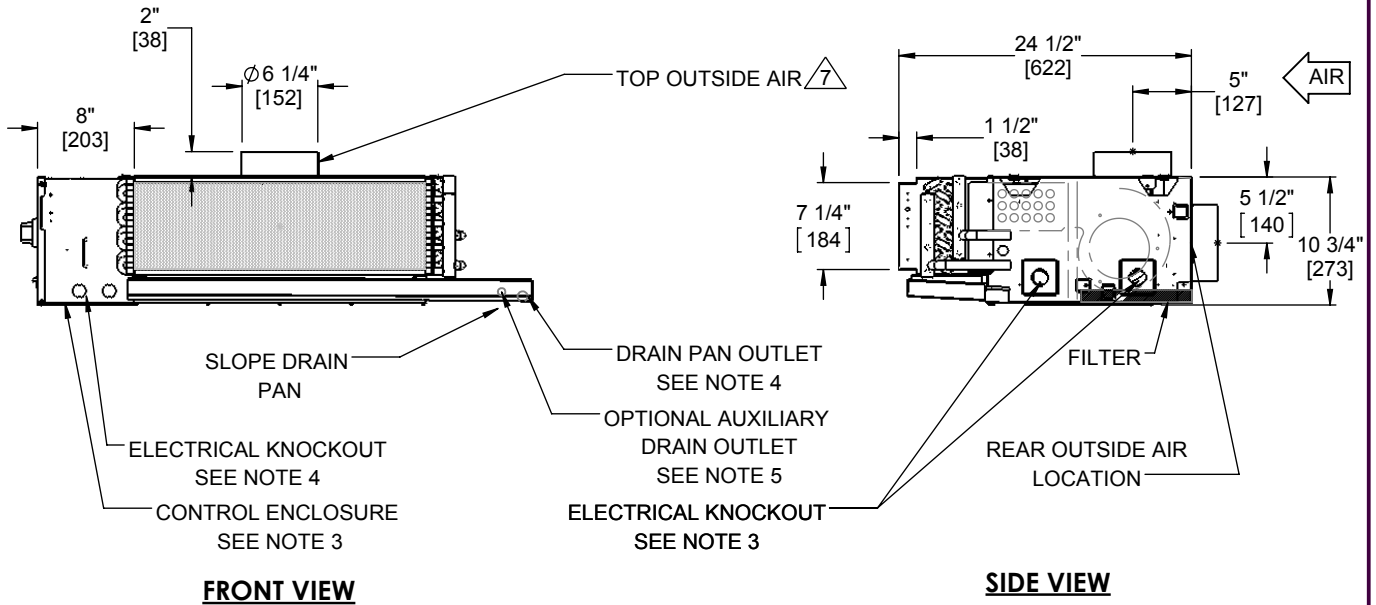

FRONT VIEW

SIDE VIEW

DIMENSIONS					
UNIT SIZE	A	B	C	D	E
02	16" [406]	17 1/4" [438]	25 1/4" [641]	16" [406]	13 3/16" [335]
03	19 1/4" [489]	20 1/2" [521]	28 1/2" [724]	19 1/4" [489]	16 7/16" [418]
04	24 1/4" [616]	25 1/2" [648]	33 1/2" [851]	24 1/4" [616]	22 11/16" [576]
06	31" [787]	32 1/4" [819]	40 1/4" [1022]	31" [787]	29 7/16" [748]
08	38" [965]	39 1/4" [997]	47 1/4" [1200]	38" [965]	36 7/16" [925]
09	42 1/4" [1073]	43 1/2" [1105]	51 1/2" [1308]	42 1/4" [1073]	40 1/2" [1029]
10	52" [1321]	53 1/4" [1353]	61 1/4" [1556]	52" [1321]	50 7/16" [1281]
12	60" [1524]	60 1/4" [1530]	69 1/4" [1759]	60" [1524]	57 1/2" [1461]

NOTES:

1. All dimensions in Inches [millimeters]. All dimensions ±1/4" [6mm]. Metric values are soft conversion.
 2. Left hand unit shown, right hand unit opposite.
 3. Standard control enclosure is mounted on unit side opposite cooling coil connections. Unit casing includes (2) knockouts on each side. Provide sufficient clearance to access electrical controls and comply with applicable codes and ordinances.
 4. Standard externally foam coated galvanized steel drain pan has 7/8" ODM copper outlet. Stainless steel drain pan has 3/4" MPT galvanized steel outlet.
 5. Aux. drain outlet is 5/8" ODM copper or 3/8" MPT galvanized steel respectively.
 6. See coil connection drawings for coil connection sizes and locations.
7. Either Top or Bottom outside air available for bottom return only.

UNCONTROLLED WHEN PRINTED



THIS DRAWING CONTAINS PROPRIETARY DATA. UNAUTHORIZED DISCLOSURE, REPRODUCTION, OR USE IS STRICTLY PROHIBITED WITHOUT WRITTEN PERMISSION.

SUBMITTAL DRAWING
ALL DRAWINGS ARE SUBJECT TO CHANGE WITHOUT PRIOR NOTICE

DO NOT SCALE DRAWING
DIMENSIONS ARE IN INCHES UNLESS OTHERWISE NOTED

TITLE:		MODEL HLP FAN COIL UNIT SERIES D OUTSIDE AIR		
DATE	SHEET	DRAWING NO	REV	
01/18/16	PAGE 1 OF 1	47-80123	00	