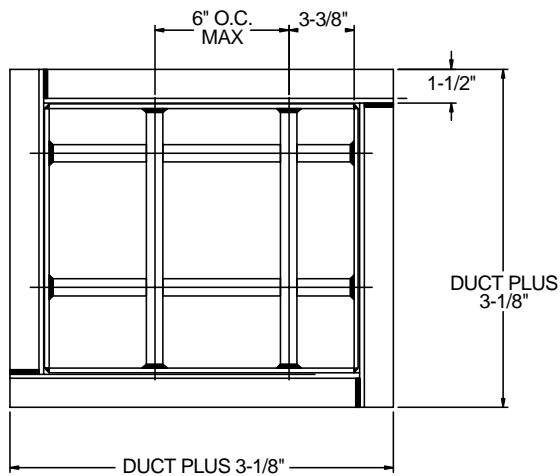
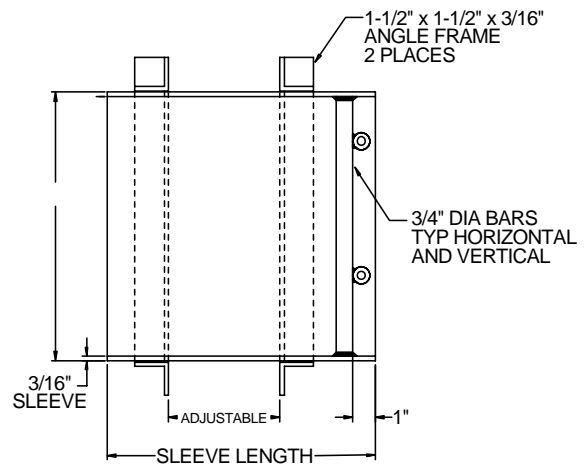

SDBS Standard Construction Details

- **Bars:** 3/4" dia. round solid steel bars with maximum opening of 6"
- **Sleeve:** 1/4" steel plate stitch welded at seams (available lengths: 6", 8", 10", 12", 18")
- **Angle Frame:** 1-1/2" x 1-1/2" x 3/16" steel angle iron welded at corners (shipped loose and unpainted for field mounting)
- **All welded construction**
- **Finish:** White (WH) or Mill (ML)

Face View Detail

Side View Detail

Note: Angle frame is standard on all SDBS models

Available Sizes:

6" x 4" to 30" x 30" in 2" increments

Dimensions are in inches. Product information subject to change without notice.

PROJECT:	SUBMITTED BY:	DATE: 2-25-02	SD-1838
ARCHITECT:		SDBS Security Duct Bars with Sleeve Steel	
ENGINEER:			
CONTRACTOR:			
LOCATION:			