

DIMENSIONS

UNIT SIZE	A	B	C	D	E	F
06	34-7/8" [886]	24-5/8" [721]	23-1/8" [587]	20" [508]	14" [356]	16" [406]
08	39-7/8" [1013]	29-5/8" [737]	28-1/8" [714]	25" [635]	19" [483]	21" [533]
10	43-7/8" [1114]	33-5/8" [838]	32-1/8" [816]	29" [737]	23" [584]	25" [635]
12	48-7/8" [1241]	38-5/8" [965]	37-1/8" [943]	34" [864]	28" [711]	30" [762]
14	53-7/8" [1368]	43-5/8" [1092]	42-1/8" [1070]	39" [991]	33" [838]	35" [889]
16	58-7/8" [1495]	48-5/8" [1219]	47-1/8" [1197]	44" [1118]	38" [965]	40" [1016]
18	63-7/8" [1622]	53-5/8" [1346]	52-1/8" [1324]	49" [1245]	43" [1092]	45" [1143]
20	67-7/8" [1724]	57-5/8" [1448]	56-1/8" [1426]	53" [1346]	47" [1194]	49" [1245]

- NOTES:**
1. All dimensions in Inches [millimeters]. All dimensions $\pm 1/4"$ [6mm]. Metric values are soft conversion.
 2. Right hand unit shown, Left hand unit opposite.
 3. Standard control enclosure is mounted on unit side opposite cooling coil connections and includes (4) knockouts on (2) sides. Provide sufficient clearance to access electrical controls and comply with applicable codes and ordinances.

UNCONTROLLED WHEN PRINTED



THIS DRAWING CONTAINS PROPRIETARY DATA. UNAUTHORIZED DISCLOSURE, REPRODUCTION, OR USE IS STRICTLY PROHIBITED WITHOUT WRITTEN PERMISSION.

SUBMITTAL DRAWING
ALL DRAWINGS ARE SUBJECT TO CHANGE WITHOUT PRIOR NOTICE

DO NOT SCALE DRAWING
DIMENSIONS ARE IN INCH (MM) FORMAT +/- 1/8 (3) UNLESS OTHERWISE NOTED

TITLE: **MODEL HPP 2-PIPE W/ ELECTRIC HEAT**

DATE	SHEET	DRAWING NO	REV
1/13/2020	PAGE 1 OF 2	82-80034	B

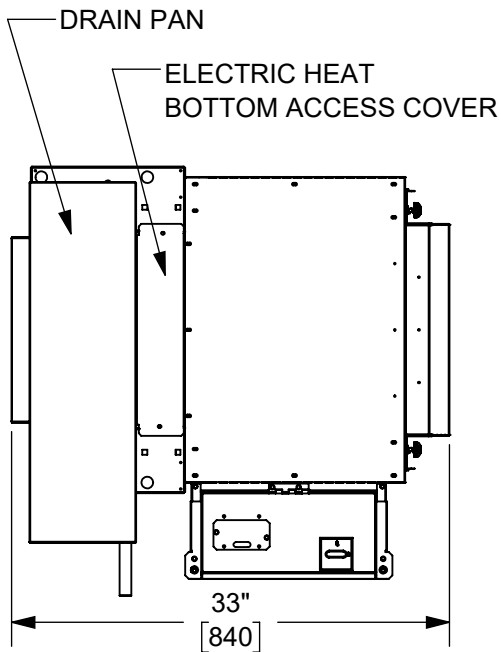

BOTTOM VIEW

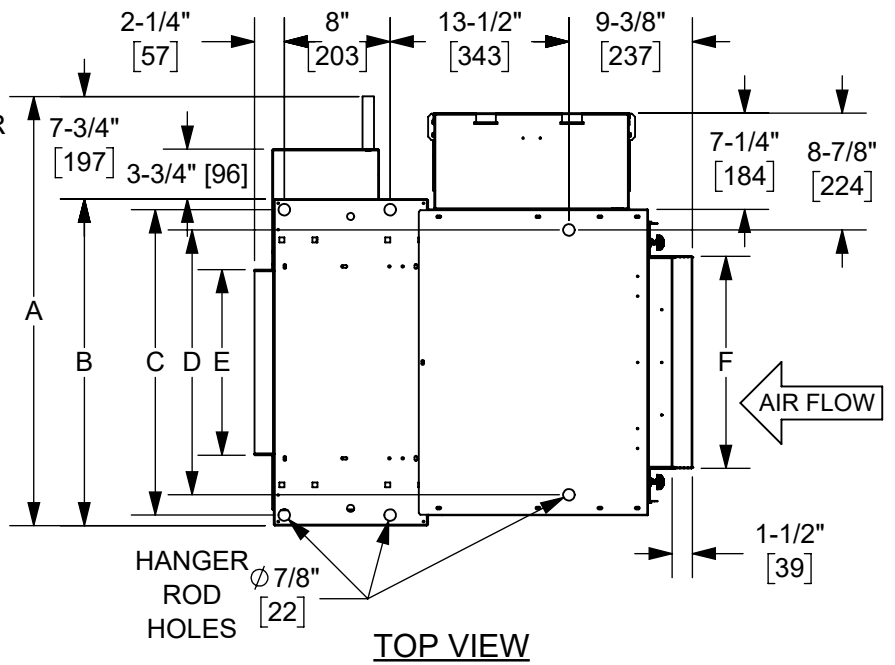

TOP VIEW

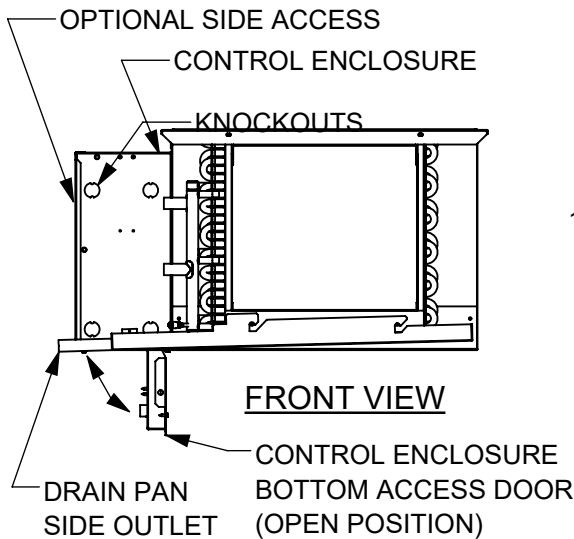

FRONT VIEW

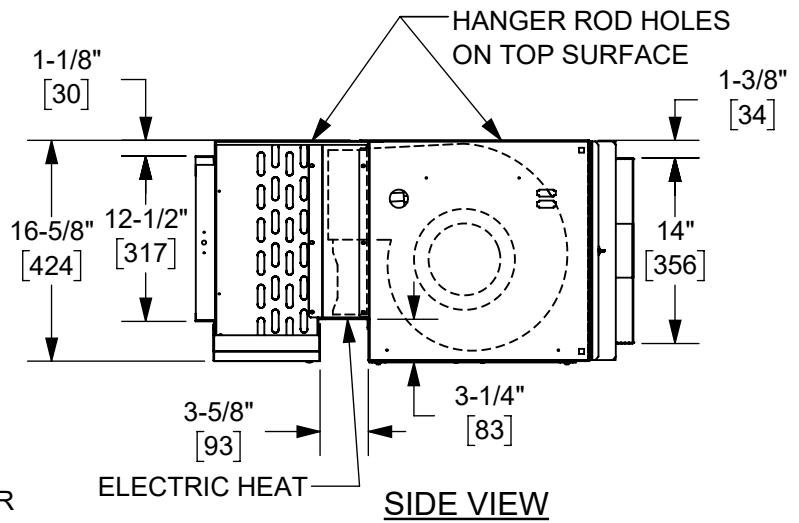

SIDE VIEW

DIMENSIONS

UNIT SIZE	A	B	C	D	E	F
06	32-3/8" [822]	24-5/8" [721]	23-1/8" [587]	20" [508]	14" [356]	16" [406]
08	37-3/8" [949]	29-5/8" [737]	28-1/8" [714]	25" [635]	19" [483]	21" [533]
10	41-3/8" [1050]	33-5/8" [838]	32-1/8" [816]	29" [737]	23" [584]	25" [635]
12	46-3/8" [1177]	38-5/8" [965]	37-1/8" [943]	34" [864]	28" [711]	30" [762]
14	51-3/8" [1304]	43-5/8" [1092]	42-1/8" [1070]	39" [991]	33" [838]	35" [889]
16	56-3/8" [1431]	48-5/8" [1219]	47-1/8" [1197]	44" [1118]	38" [965]	40" [1016]
18	61-3/8" [1558]	53-5/8" [1346]	52-1/8" [1324]	49" [1245]	43" [1092]	45" [1143]
20	65-3/8" [1660]	57-5/8" [1448]	56-1/8" [1426]	53" [1346]	47" [1194]	49" [1245]

NOTES:

1. All dimensions in Inches [millimeters]. All dimensions $\pm 1/4"$ [6mm]. Metric values are soft conversion.
2. Right hand unit shown, Left hand unit opposite.
3. Same side control enclosure shown mounted on unit side same as cooling coil connections and includes (4) knockouts on (2) sides. Provide sufficient clearance to access electrical controls and comply with applicable codes and ordinances.

UNCONTROLLED WHEN PRINTED



THIS DRAWING CONTAINS PROPRIETARY DATA. UNAUTHORIZED DISCLOSURE, REPRODUCTION, OR USE IS STRICTLY PROHIBITED WITHOUT WRITTEN PERMISSION.

SUBMITTAL DRAWING
ALL DRAWINGS ARE SUBJECT TO CHANGE WITHOUT PRIOR NOTICE

DO NOT SCALE DRAWING
DIMENSIONS ARE IN INCH (MM) FORMAT +/- 1/8 (3) UNLESS OTHERWISE NOTED

TITLE:
MODEL HPP 2-PIPE W/ ELECTRIC HEAT

DATE	SHEET	DRAWING NO	REV
1/13/2020	PAGE 2 OF 2	82-80034	B