

NOTES:

1. All dimensions are Inches [millimeters]. All dimensions are $\pm 1/4"$ [6mm]. Metric values are soft conversion.
2. Left hand unit shown. Right hand unit opposite. Motor/drive location may be specified Left or Right Hand. Standard control enclosure location matches motor/drive position.
3. Provide sufficient clearance to access electrical controls and comply with all applicable codes and ordinances.
4. Base rail designed for use with floor mount vibration isolators. See drawing BR-001 for base rail details.

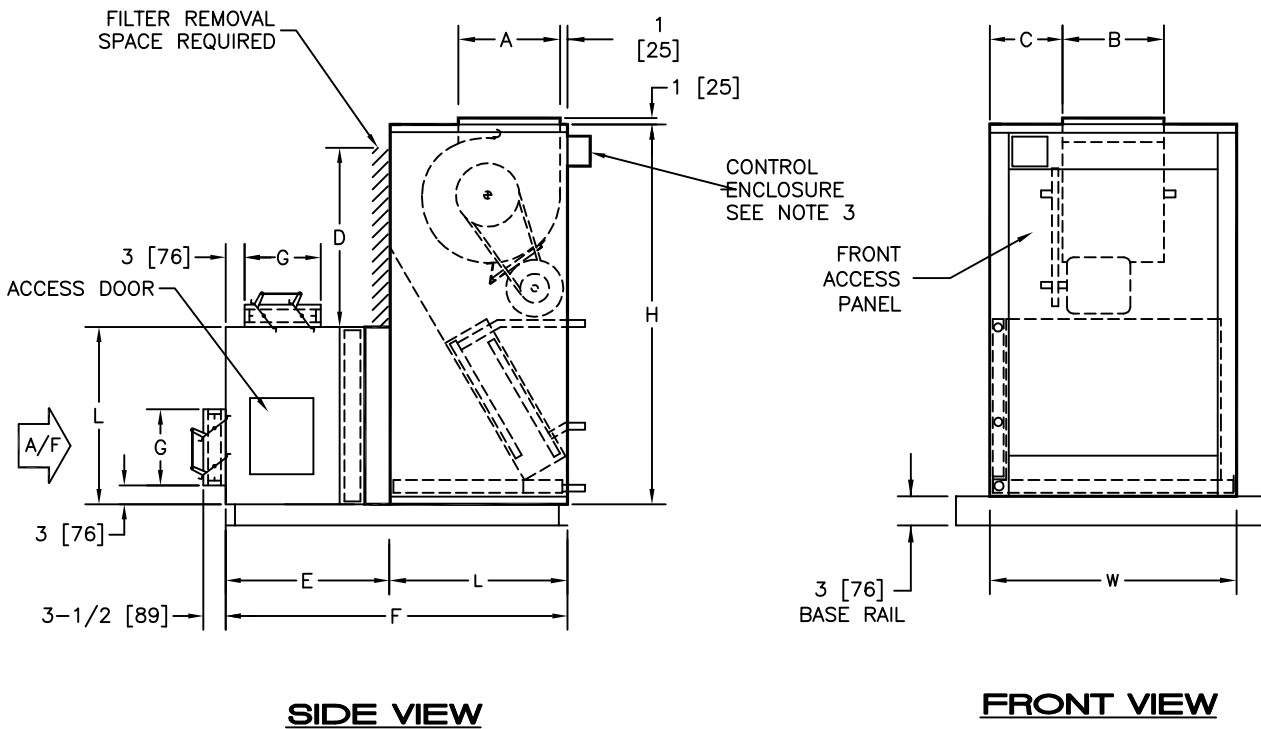
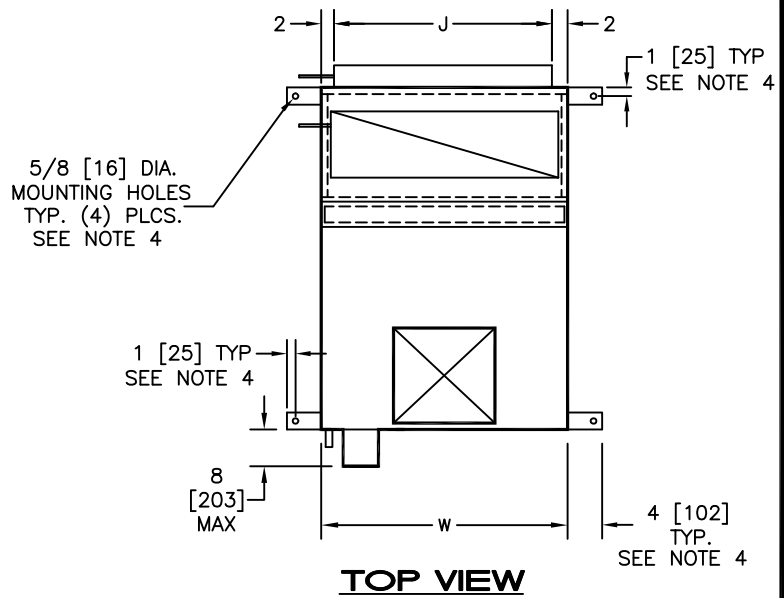

DIMENSIONS - In [mm]

UNIT SIZE	FILTER SIZE	QTY	H	W	L	A	B	C	D	E	F	G	J
08	16 X 20 X 2 [406 X 508 X 51]	1	46 [1168]	26 [660]	19 [483]	6-1/2 [165]	6-7/8 [175]	9-9/16 [243]	16 [406]	15 [381]	35 [889]	6 [152]	22 [559]
12	20 X 20 X 2 [508 X 508 X 51]	1	46 [1168]	26 [660]	21 [533]	7-1/2 [190]	8-1/4 [210]	8-7/8 [225]	20 [508]	18 [457]	40 [1016]	9 [229]	22 [559]
16	24 X 24 X 2 [610 X 610 X 51]	1	54 [1372]	29 [737]	25 [635]	7-1/2 [190]	10-1/4 [260]	9-3/8 [238]	24 [610]	18 [457]	44 [1118]	9 [229]	25 [635]
20	24 X 24 X 2 [610 X 610 X 51]	1	54 [1372]	29 [737]	28 [711]	11-3/8 [289]	13-1/4 [337]	7-7/8 [200]	24 [610]	21 [533]	50 [1270]	12 [305]	25 [635]
25	24 X 24 X 2 [610 X 610 X 51]	1 EACH	60 [1524]	39 [991]	28 [711]	13-1/2 [343]	12-7/8 [327]	13-1/16 [332]	24 [610]	21 [533]	50 [1270]	12 [305]	35 [889]
30	12 X 24 X 2 [305 X 610 X 51]	1 EACH	60 [1524]	39 [991]	28 [711]	15-1/4 [387]	15 [381]	12 [305]	24 [610]	21 [533]	50 [1270]	12 [305]	35 [889]

TITLE: MODEL VMR SERIES "C"
WITH INLET DAMPER SECTION (REQUIRES BASE RAIL)
BELT DRIVE BLOWER COIL UNIT
DISCHARGE ARG. 2



DRN BY: DVG	DATE: 4/3/08	SCALE: NA	DRAWING NO.
CKD BY: M. HAYES	DATE: 12/03/08	REV: 01	

52-80020

THIS DRAWING CONTAINS PROPRIETARY DATA.
UNAUTHORIZED DISCLOSURE, REPRODUCTION, OR USE
IS STRICTLY PROHIBITED WITHOUT WRITTEN PERMISSION

DO NOT SCALE DRAWING
DIMENSIONS AND DATA ARE SUBJECT TO CHANGE WITHOUT NOTICE.
CONTACT FACTORY FOR CERTIFIED DRAWINGS.