



ENVIRO-TEC

FAN POWERED VAV TERMINALS

INSTALLATION, OPERATION & MAINTENANCE

Supersedes ET130.13-NOM6 (0421)

Form ET130.13-NOM6 (0225)

MODELS CRB & CRQ



TABLE OF CONTENTS

SAFETY CONSIDERATIONS.....	4
INSPECTION	5
STORAGE	5
PRE-INSTALLATION INSPECTION.....	5
SEQUENCE OF OPERATION.....	6
INSTALLATION	6
CLEARANCES.....	6
HANGING AND MOUNTING EQUIPMENT OVERHEAD.....	6
DUCT CONNECTIONS.....	7
SOUND CRITICAL APPLICATIONS	7
COOLING/HEATING MEDIUM CONNECTIONS.....	7
ELECTRICAL CONNECTIONS	8
ELECTRICAL ENCLOSURE	8
180-DEGREE UNIT FLIP AND ACCESS DOOR REASSIGNMENT.....	9
OPERATION	9
START-UP	9
POWER REQUIREMENTS.....	9
PRIMARY AIR DAMPER AND FAN ADJUSTMENT	9
EC MOTORS.....	9
SERVICE AND CLEARANCE REQUIREMENTS.....	10
HOT WATER COIL CONNECTIONS	14
VALVE PACKAGE COIL CONNECTIONS	19
INSPECTION AND STARTUP CHECKLIST.....	25
MAINTENANCE	26
FACTORY PROVIDED DAMPER ACTUATOR.....	26
DAMPER SHAFT.....	26
MOTOR/BLOWER ASSEMBLY.....	26
CLEANING.....	26
REMOVAL AND REPLACEMENT.....	26
COIL.....	20
CLEANING.....	20
REMOVAL AND REPLACEMENT.....	28
ELECTRIC HEAT	28
REMOVAL AND REPLACEMENT.....	28
FILTERS.....	29
FILTERS, THROWAWAY	29
FACE AREA, FREE AREA, AND FILTER SIZES.....	30
GENERAL TROUBLESHOOTING GUIDELINES	31
VALVE CALIBRATION CHARTS	32
FAN CFM CALIBRATION CURVE EXAMPLES	33
TERMINAL UNIT WEIGHTS	34
FACTORY REPLACEMENT PARTS AND WARRANTY	35
COMPONENT INSTALLATION, OPERATION AND MAINTENANCE APPENDIX	36

SAFETY SYMBOLS

The following symbols are used in this document to alert the reader to areas of potential hazard:



DANGER indicates an imminently hazardous situation which, if not avoided, will result in death or serious injury.



CAUTION identifies a hazard which could lead to damage to the machine, damage to other equipment and/or environmental pollution. Usually an instruction will be given, together with a brief explanation.



WARNING indicates a potentially hazardous situation which, if not avoided, could result in death or serious injury.

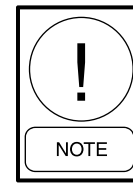

NOTE is used to highlight additional information which may be helpful to you.

SAFETY CONSIDERATIONS

The equipment covered in this manual is designed for safe and reliable operation when installed and operated within its design specification limits. To avoid personal injury or damage to equipment or property while installing or operating this equipment, it is essential that qualified, experience personnel familiar with local codes and regulations, perform these functions using good judgment and safe practices. *See the following cautionary statements.*



ELECTRICAL SHOCK HAZARDS
All power must be disconnected prior to installation and servicing this equipment. More than one source of power may be present. Disconnect, lock out and tag out all power sources to avoid electrocution or shock hazards.



ROTATING EQUIPMENT HAZARD
Fans may start automatically. Disconnect all power and control circuits prior to servicing to avoid injury. Caution should be exercised due to the possibility of fans “free wheeling” due to connected duct air movement.



HOT PARTS HAZARD
Electric heaters may start automatically. Disconnect all power and control circuits prior to servicing to avoid burns.



Check that rigging and lifting equipment can safely support the equipment assembly and component weights.



All assemblies must be adequately secured during lifting and rigging by temporary supports and restraints until equipment is permanently fastened and set in its final location per manufacturer’s guidelines.



All temporary and permanent equipment supports must be capable of safely supporting the equipment’s weight as well as any additional live, seismic or dead loads that may be encountered. All supports must be designed to meet applicable local codes and ordinances.



All fastening devices must be designed to mechanically lock the assembly in place without the capability of loosening or breaking away due to system operation and vibration.

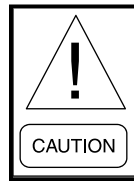

Dampers may activate automatically. Disconnect the control circuits or pneumatic control systems and secure all dampers when servicing damper, actuators or linkage to avoid injury.

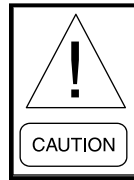

Wear the appropriate personal protective equipment (gloves, safety glasses, leather closed toe shoes, etc) when handling this equipment recognizing that sheet metal components are being handled.

INSPECTION

Upon receipt of equipment, carefully check all items against the bill of lading to ensure that all equipment has been received (including shipped loose items). Note any discrepancy on the bill of lading before signing. Note that “ship loose” items may be included with the base unit or shipped (bulk) on a separate pallet.

Inspect all equipment for any signs of damage caused during transit. Note any visual damage on the bill of lading before signing. **Immediately report all visual and concealed damage to the carrier and file a claim with the carrier.**

Locate the model number on the nameplate and check that the correct equipment has been received. Verify that all options have been included, such as controls, filters, heating and/or cooling coils, etc. Also check that equipment voltage agrees with the building parameters. If a discrepancy is discovered between what was ordered and received, contact your local Enviro-Tec representative immediately.

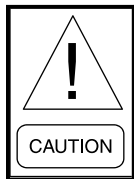

Do not use airflow sensor, connecting tubes, coil stubouts or damper shaft as a handle when lifting or moving equipment as damage may occur.



Do not handle by equipment's heating elements, as permanent damage will occur.



Check assembly and component weights to be sure that the rigging equipment can handle them safely. Note; also check the centers of gravity and any specific rigging instructions.



Check for adequate ventilation so fumes do not migrate through ductwork to occupied spaces when welding or cutting around the equipment.



Do not work on damper until associated actuator is disconnected.

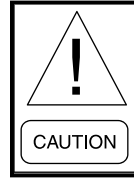

Never pressurize equipment above specified test pressure.

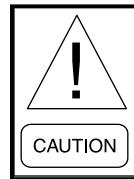

Protect adjacent flammable materials when brazing. Use flame and heat protection barriers where need. Have a fire extinguisher at hand and ready for immediate use.

STORAGE

If equipment is to be stored prior to installation, observe the following precautions:

1. Choose a dry storage site that is reasonably level and sturdy to prevent undue stress or permanent damage to the equipment. Set equipment off ground if in moisture prone areas.
2. Cover entire equipment with protective tarp or moisture proof cover. Extend cover under equipment if stored on ground. Secure cover with adequate tie downs. Be sure that piping connections have protective shipping caps installed.
3. Do not stack equipment any higher than how it was shipped. If equipment has been unpackaged since receipt from the factory, do not stack without equivalent support between units as was supplied from the factory.
4. To prevent motor seizure, motors should be hand-turned once every six months. To prevent EC Motor capacitor drainage, EC motors should have power applied to them once every six months.

PRE-INSTALLATION INSPECTION



Do not use flow sensor, connecting tubes, coil stubouts or damper shaft as a handle when lifting or moving equipment as damage may occur.

Do not handle by equipment's heating elements, as permanent damage will occur.

While viewing the damper from the discharge of the equipment, disengage the actuator by depressing the manual override button on the side of the actuator and rotate the shaft fully. The damper should close fully and there should be no gaps between the damper gasketing and the inside of the valve.

Manually rotate the fan wheel to assure that there are no obstructions within the fan housing.



Equipment supplied with EC motors, backward or reverse rotation of the blower is detrimental to the EC motor. Fan must be energized prior to introduction of air through the primary air valve or the possibilities exist that the fan wheel will operate backwards / counter rotation.

SEQUENCE OF OPERATION

All series flow, fan-powered equipment is supplied with a rectangular discharge and comes in one of the following configurations:

1. Series flow with hot water coils mounted on the discharge opening.
2. Series flow with electric heat rack assembly installed into discharge duct, with flanged discharge opening.
3. Series flow cooling only with flanged discharge opening

Series Flow

On series flow equipment, the fan runs continuously whenever the central air handler is in operation, with the unit controller ultimately determining unit operation. Operational characteristics may vary depending on control type (factory, field-provided, or consignment).

In response to the space temperature, the air valve modulates the volume of primary air. The reheat is typically off during the air valve's modulation. Should the space temperature decrease to the point at which a decrease in primary air will not maintain the desired temperature, the reheat will be activated to increase the discharge air temperature.

INSTALLATION

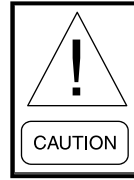

Do not use flow sensor, connecting tubes, coil stubouts or damper shaft as a handle when lifting or moving equipment as damage may occur.

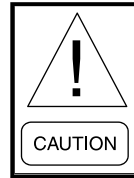

Do not handle by equipment's heating elements, as permanent damage will occur.

Terminal equipment with electric heat must be installed in a horizontal plane with respect to the air stream.

Clearances

Units with electric heat are ETL listed for 0.0" clearance to combustibles. Refer to NEC and/or local codes for minimum electrical clearances required for all other service. Equipment should not make contact with any structure located above or below the equipment without appropriate isolation. Equipment supplied with top and/or bottom access panels requires sufficient clearance to remove access panels for service.

Hanging and Mounting Equipment Overhead

ENVIRO-TEC strongly recommends that all equipment be suspended from the upper most ceiling or a structural element of the building, independent of the false ceiling grid. Suspension devices are field supplied, sized and designed by others. ENVIRO-TEC will not accept responsibility for equipment mounting supports. Equipment must be installed in a level horizontal plane. Failure to level equipment properly may prevent proper operation of unit.

CRB and CRQ series flow, fan-powered VAV units are supplied with integral hanger brackets for use with (up to) a 3/8" [10mm] diameter hanger rod. Use of the integrated hanger brackets is the preferred method for hanging and mounting the unit. For optimal unit stability and vibration isolation, hanger rods can be routed through both the top and bottom integral hanger brackets, and secured accordingly. *See submittal drawings for hanger bracket locations.*

Hanger straps may be utilized as an alternate means of suspending the equipment. Do not secure hanger straps to electric heater ducts, coils, or control enclosures. Hanger straps can be mounted directly to the sides and bottom of equipment casing, such that they do not interfere with working components or access panels. Before securing screws, ensure they will not damage internal components. Screw length should be limited to 5/8".

When hanging equipment, always use the support method as prescribed for rectangular duct in the job specifications. If unit is to be flipped in the field, refer to 180-degree unit flip and access door reassignment instructions on page 9.

Duct Connections

All duct connections should be configured and installed in accordance with SMACNA guidelines and all local code requirements. Check to see that duct fasteners are appropriate for the application and do not impinge any internal components. Pay particular attention to internal electrical components.

Fasten and seal all ductwork connections in accordance with project specifications. Allow a minimum of 1½ duct diameters of straight duct prior to equipment inlet.

The diameter of the inlet duct for round valves must be equal to the listed size of the equipment. The round air valve inlet collar of the equipment is 1/8" smaller than listed size in order to allow the round ductwork to slip over the air valve inlet collar. **DO NOT INSERT DUCTWORK INTO AIR VALVE INLET COLLAR.**

When making ductwork connection to air valve inlet collar and insulating air valve inlet, take caution not to damage or remove the flow sensor connections, which are vital to equipment control.

Provide insulation around entire inlet collar (all the way to the equipment casing).

Cut "slits" in the insulation for the flow tubes and secure with duct tape.

Permissible discharge duct connections are straight flanged, slip and drive or drive and screw.

After all connections are made, check that the entire ductwork system is airtight. In some high-pressure systems, duct sealer may be necessary.

Sound Critical Applications

Flexible duct connectors are not recommended on equipment discharge. The sagging membrane of these fittings can cause turbulence and locally high air velocities that generate noise. Also, lightweight membrane material allows noise to break out, which can increase sound levels in the space below.

Cooling/Heating Medium Connections

Hot water coils are male sweat connection. Use appropriate brazing alloy for system temperature and pressure. Refer to equipment construction submittal drawing for specific connection size. **MAXIMUM HYDRONIC COIL OPERATING PRESSURE MUST NOT EXCEED 450 PSIG.**

In the event that leaking or defective components are discovered, the Sales Representative must be notified BEFORE any repairs are attempted. All leaks should be repaired before proceeding with the installation.

Valves must be secured and supported to avoid damage to coil headers. All valves, pipes, and components must be sufficiently supported to ensure structural integrity and proper operation of the unit.

After system integrity has been established the piping should be insulated in accordance with the project specifications. ALL chilled water and drain pan piping not located over drain pans must be insulated to prevent damage from sweating. This includes factory and field piping inside the unit cabinet.

If necessary, you can change coil connection handing on one and two row coils from left-hand to right-hand (and vice-versa) by rotating the coil "like a steering wheel" 180° about its central axis when facing the fins.

NOTE: When the coil is flipped, the vent will no longer perform in a vent capacity. It is suggested that valve packages are re-oriented during this process to bring the valve actuator back to its original position. **For three and four row coils, consult factory.**

Electrical Connections

All field wiring must comply with NEC and all local codes. Electrical and control diagrams are affixed to the interior of the control enclosure box. All supply voltage connections are to be made to the provide terminals. Refer to wiring diagram provided with unit.

Minimum circuit ampacity (MCA) designates the maximum operating load of the equipment for sizing wire feeders. Supply Circuit Protection designates the largest breaker in the electrical service panel that can be used to protect the equipment.

Use Copper conductors only.

Electrical Enclosure

The integrated electrical control enclosure with hinged bottom access and removable side access panels provides access to the high voltage and low voltage electrical compartments. These compartments house all line level, electric heat, and control components. Terminal strips are furnished for supply power and control wiring connections. Multiple knockouts allow wiring entries from either side of the compartment.

All components furnished for field installation, by either the factory or the controls contractor should be located and checked for proper function and compatibility. All internal components should be checked for shipping damage and all electrical connections should be tightened to minimize problems during start-up.

Any devices such as thermostats that have been furnished from the factory for field installation must be wired in strict accordance with the applicable wiring diagrams. Failure to do so could result in personal injury or damage to components and will void all manufacturers' warranties. The fan motor(s) should never be controlled by any wiring or device other than the factory furnished switch or thermostat/switch combination, without factory authorization.

All field wiring should be done in accordance with governing codes and ordinances. Any modification of the unit wiring without factory authorization will result in voiding of all factory warranties and will nullify any agency listings. The manufacturer assumes no responsibility for any damages and/or injuries resulting from improperly field installed or wired components. Prior to unit startup, ensure that all wiring connections to the terminal strip are securely tightened.



Control enclosure with hinged bottom access doors. To obtain control enclosure access, grasp door(s) and pull downward to release.



Additional side access control enclosure panels. To obtain control enclosure access, locate and remove securing screws, carefully remove panel(s) away from unit.

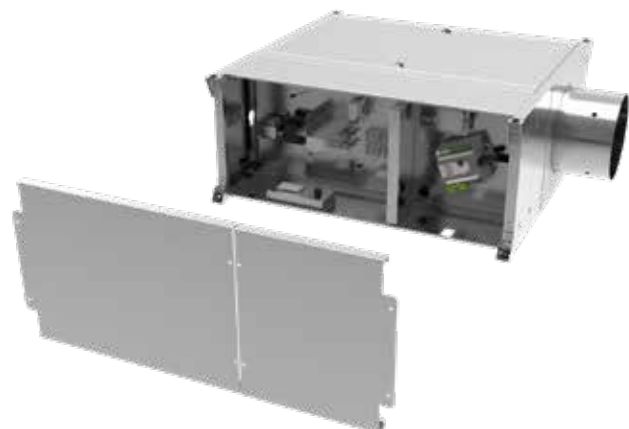

180-Degree Unit Flip And Access Door Reassignment For Integral Enclosure



ELECTRICAL SHOCK HAZARDS
All power must be disconnected prior to installation and servicing this equipment. More than one source of power may be present. Disconnect, lock out and tag out all power sources to avoid electrocution or shock hazards.

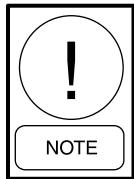

Units over 48A and/or with dual point power are not flippable due to fuse location.

1. Locate line voltage and control voltage doors, remove door hinges from the unit, and set doors aside.
2. Remove electrical enclosure side access panels.
3. Remove electrical enclosure top access panel.
4. Uninstall unit from hanger rods (if applicable), flip unit 180 degrees, reinstall unit to hanger rods.
5. Reinstall electrical enclosure top access panel to top of unit.
6. **If unit has disconnect switch or line block option:** Remove the line voltage enclosure central bracket, flip 180 degrees, and reinstall.
7. **If unit has toggle switch option:** Remove the toggle switch and toggle switch bracket. Relocate toggle switch and toggle switch bracket to the bottom side of the electrical enclosure.
8. Reinstall electrical enclosure side access panels.
9. Reinstall control enclosure door, line voltage door, and hinges to the bottom of the unit.

OPERATION

Start-Up

Thorough safety precautions should always be taken when performing startup and service. Refer to safety considerations at the beginning of this Operation Manual and the Inspection & Start-Up Checklist in this section. Only qualified individuals should perform these tasks.

Prior to start-up, the project control sequence/wiring diagram should be obtained and thoroughly understood.

If factory-supplied or consignment DDC controls are utilized, refer to the applicable Operation Manual for start-up and balancing information. Check that all electrical work is finished and properly terminated. Check that all electrical connections are tight and that the proper voltage is connected.

Power Requirements

Three Phase AC power imbalance must not exceed 2%. Be sure that the following guides are met:

1. AC power is within 5% of rated voltage at rated frequency. *(See equipment nameplate for ratings)*
2. AC power total harmonic distortion (THD) must be limited to 5%.

Primary Air Damper And Fan Adjustment

Unit should not be balanced until the incoming power supply is at the permanent voltage condition. All discharge ductwork must be connected. The minimum recommend discharge static pressure for all fan-powered equipment is 0.1" wg. and 0.2" on 3/4hp and larger *(see fan curves located on the Enviro-Tec website for specifics)*.

Max ESP is 0.25" on PSC motors, and Max ESP is 0.6" on all EC motors.

All foreign materials should be removed from the duct system. Optional filters should be installed as required.

EC Motors

For units with EC motors, all fan-powered equipment is shipped with an Solo or Sync PWM Motor Control Board. On standard units, the Solo or Sync Control Board is mounted directly in the bottom electrical control enclosure access door. On units with a 90-degree enclosure, the Solo or Sync PWM is mounted on the front of the enclosure door.

For units utilizing the Solo Board, fan speed parameters are pre-set at the factory, based on unit-specific fan curve selections.

For specific balancing instructions related to the Solo and Sync PWM Motor Control Boards, please refer to the EC Motor Solo, Select and Sync PWM IOM located at the Enviro-Tec website IOM section: www.enviro-tec.com/literature/iom. An example of the fan calibration curve is located on page 33 of this IOM. A unit-specific fan calibration curve will be affixed to the unit.

MODEL CRB SIZES 07-25 WITH ELECTRIC HEAT

Service And Clearance Requirements

Drawings not for installation purposes. Refer to unit and size-specific
submittal drawings for installation.

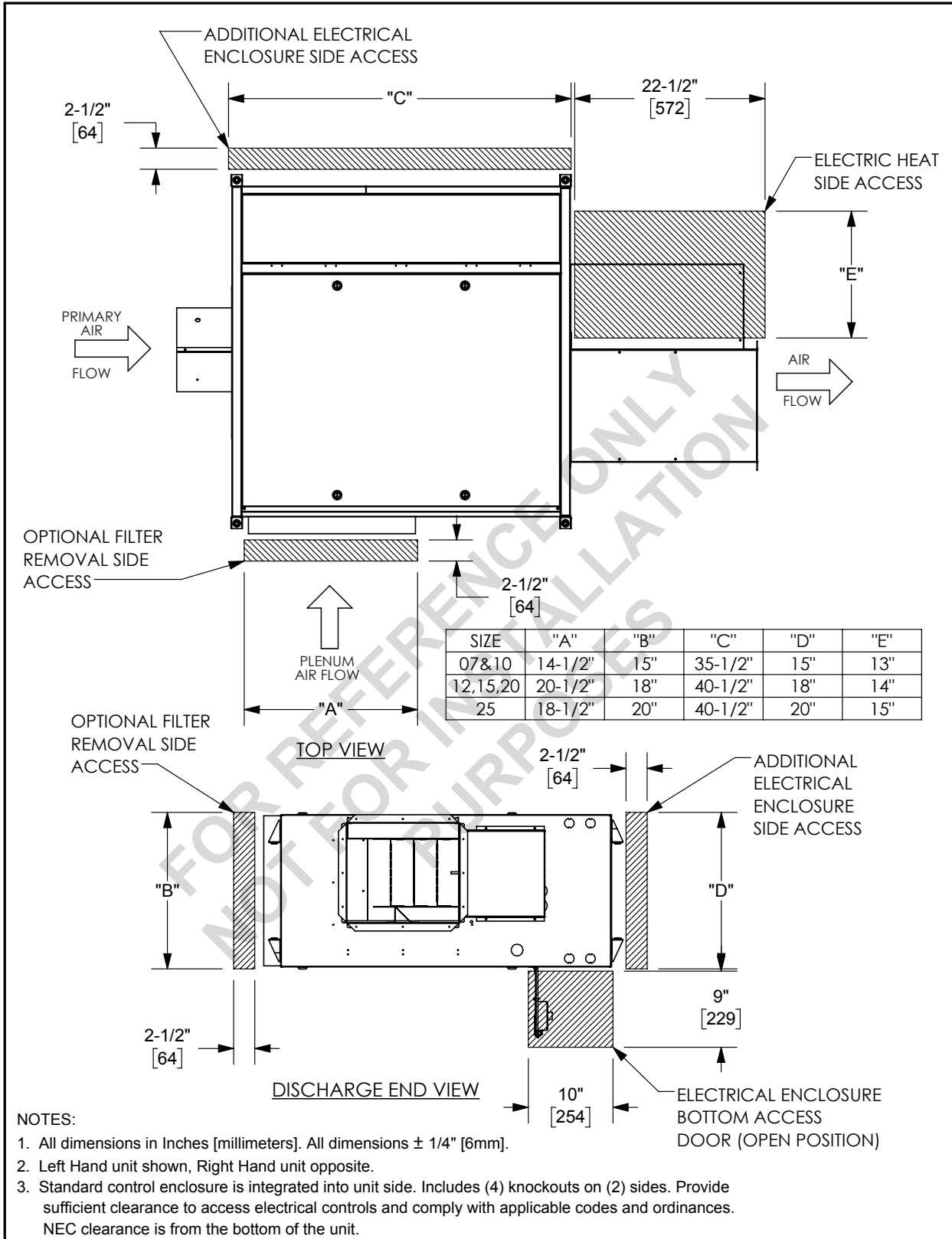

MODEL CRB SIZES 07-25 WITH HOT WATER COIL

Service And Clearance Requirements

Drawings not for installation purposes. Refer to unit and size-specific
submittal drawings for installation.

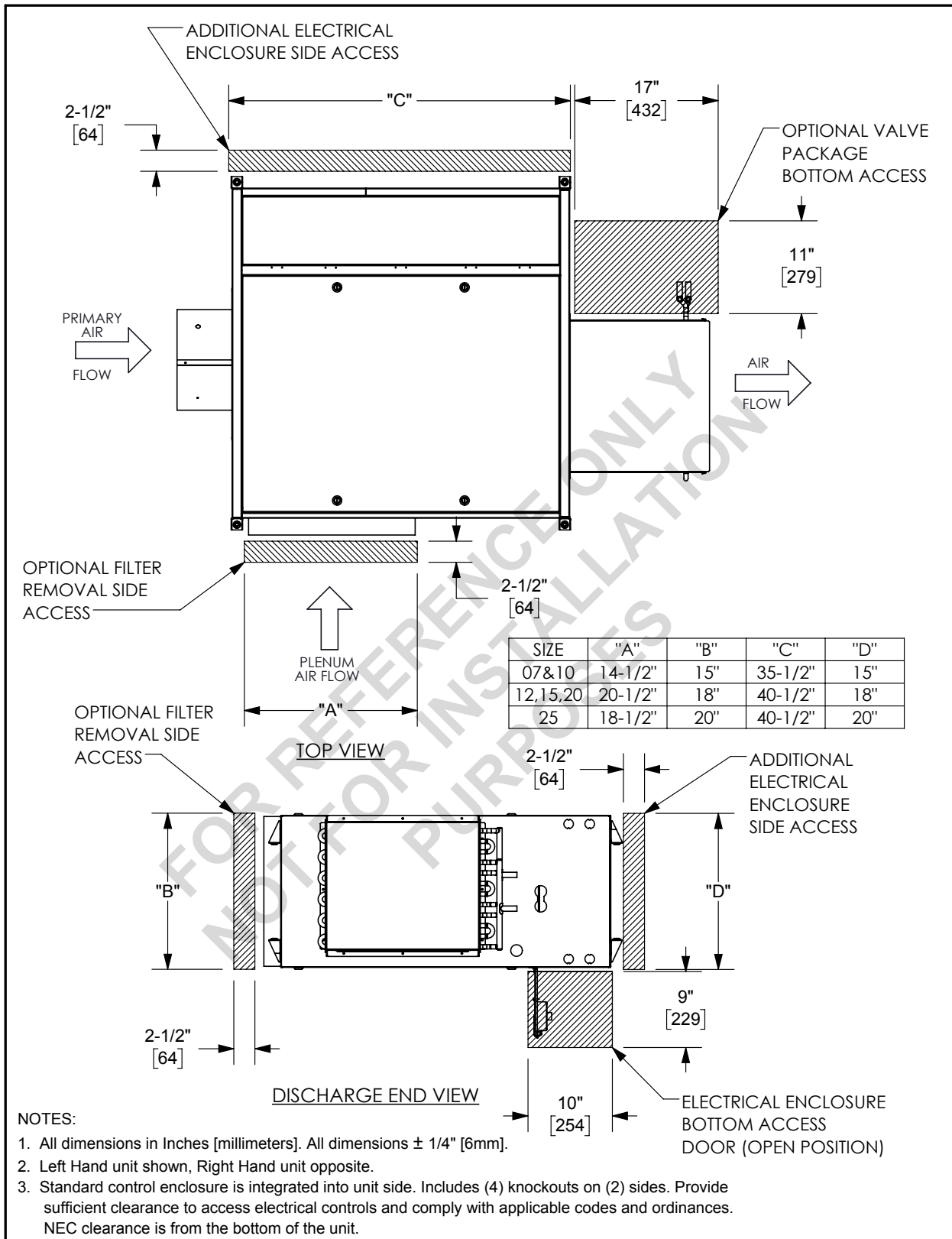

MODEL CRQ SIZES 07-25 WITH ELECTRIC HEAT Service And Clearance Requirements

Drawings not for installation purposes. Refer to unit and size-specific
submittal drawings for installation.

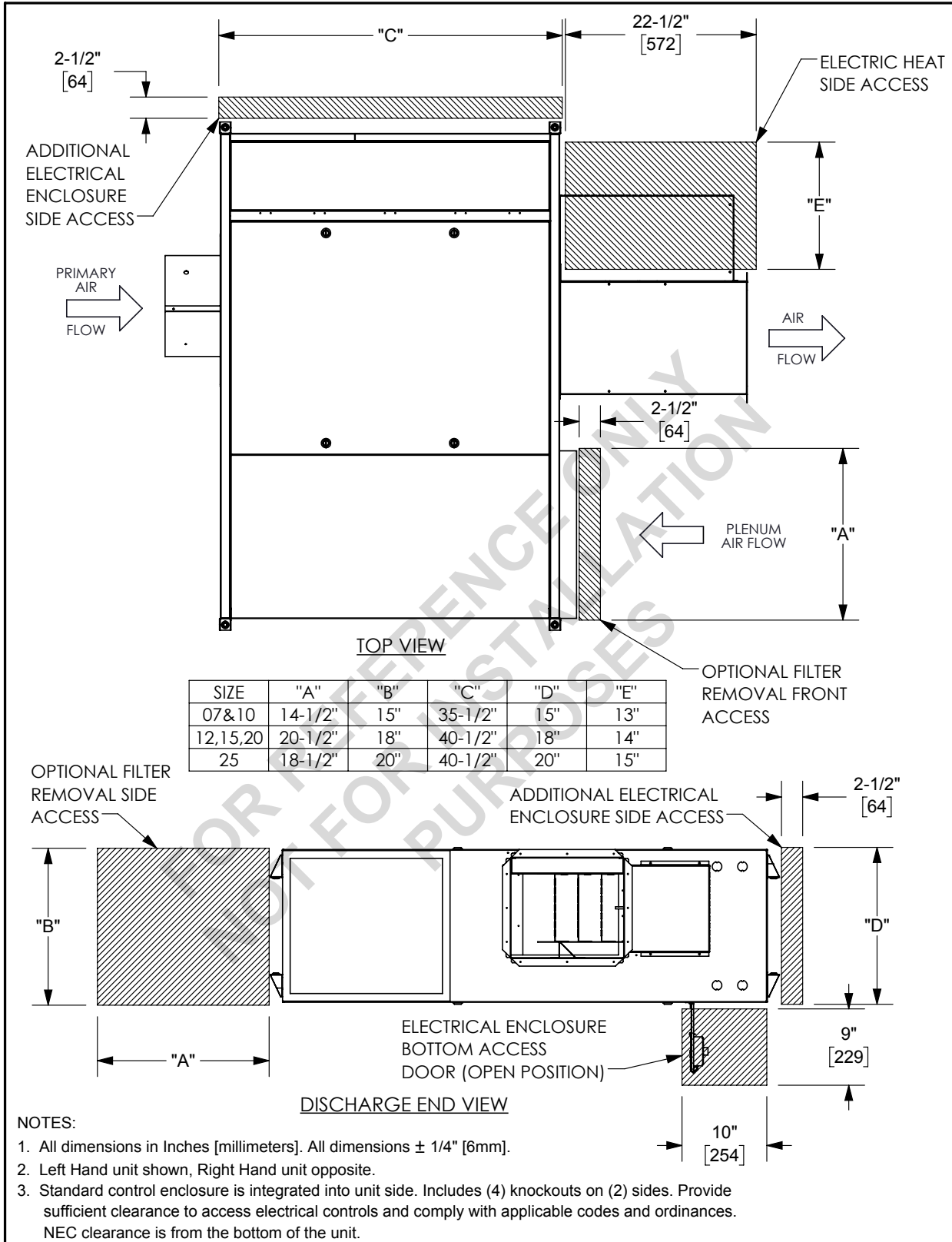

MODEL CRQ SIZES 07-25 WITH HOT WATER COIL

Service And Clearance Requirements

Drawings not for installation purposes. Refer to unit and size-specific submittal drawings for installation.

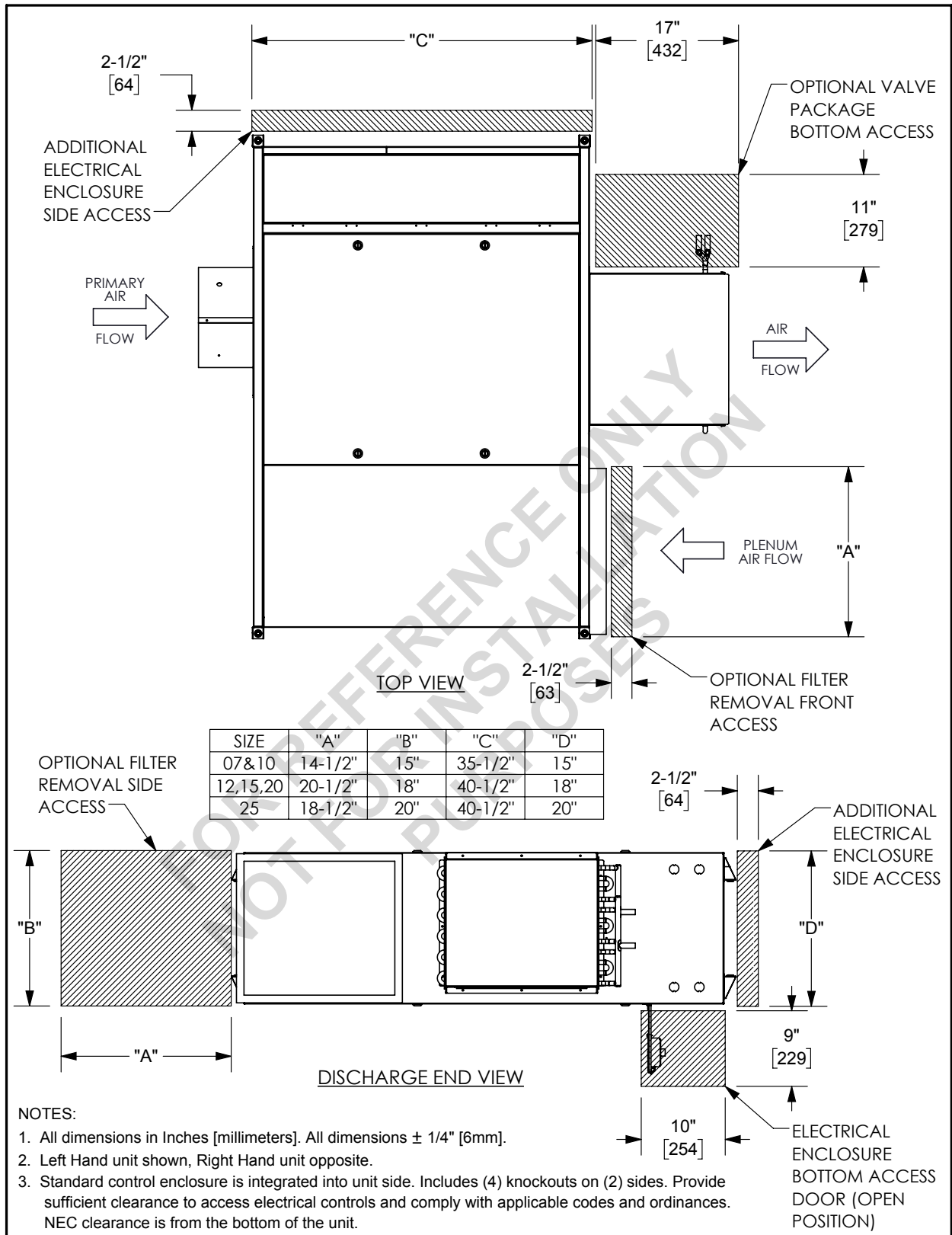

MODEL CRB AND CRQ SIZE 07 3/8" Hot Water Coil Connections, Single Circuit

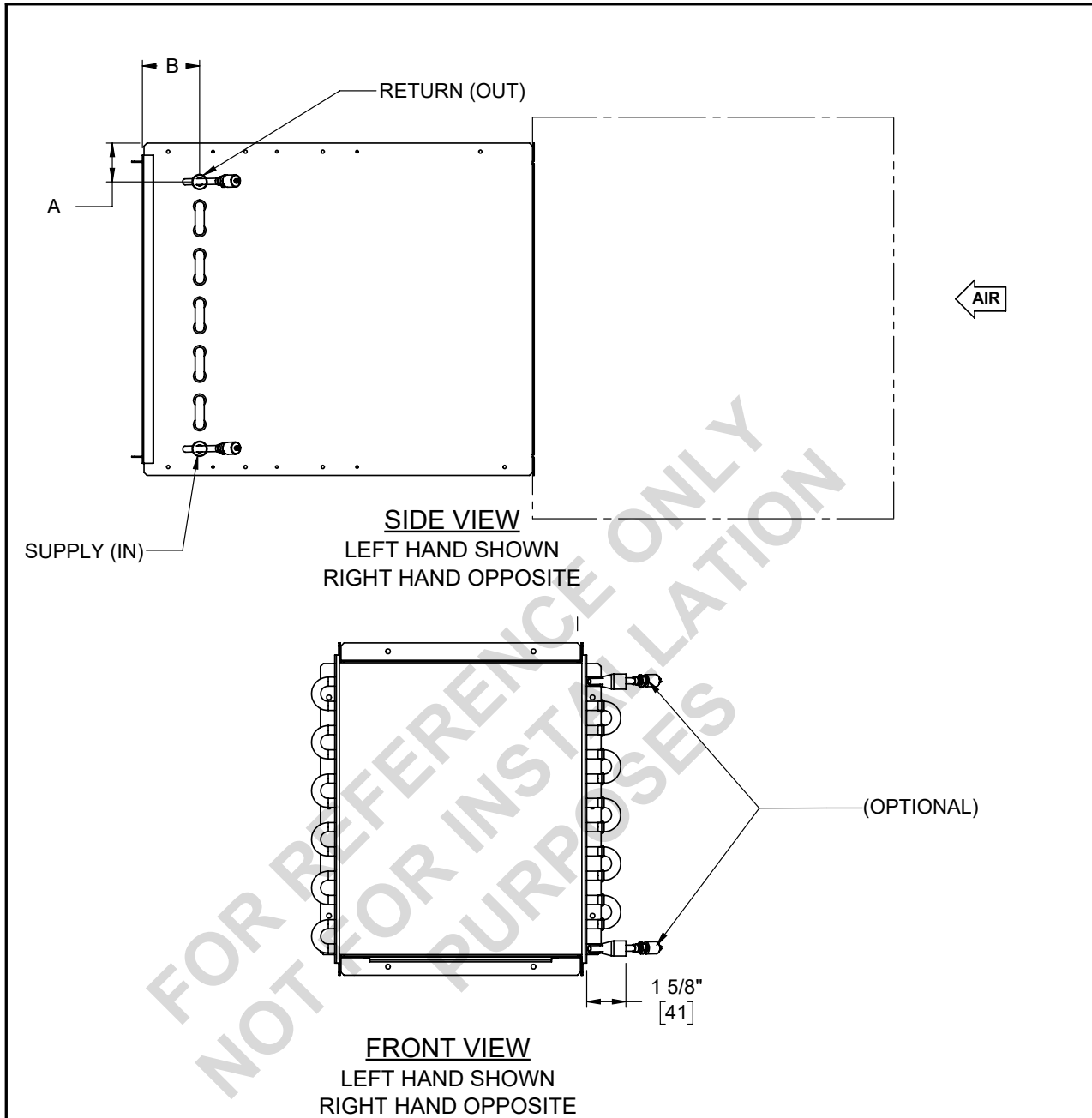

NOTES:

1. All dimensions are in inches [millimeters]
2. All dimensions may vary in $\pm 1/2$ [13mm].
Metric values are soft conversion.
3. All drawings are subject to change without notice.
4. Connection Size: 5/8 ODM (1/2" NOM.)
5. This sheet applies to single circuit coils only.
For multiple circuit coils refer sheet no 1.

SINGLE CIRCUIT COILS ONLY

Unit Size	Coil Rows	No. of Circuits	(3/8" ϕ Coil)	
			A	B
7	1	1	1-3/4" [46]	2-3/8" [60]

MODEL CRB AND CRQ SIZES 07-25

3/8" Hot Water Coil Connections, Multiple Circuits

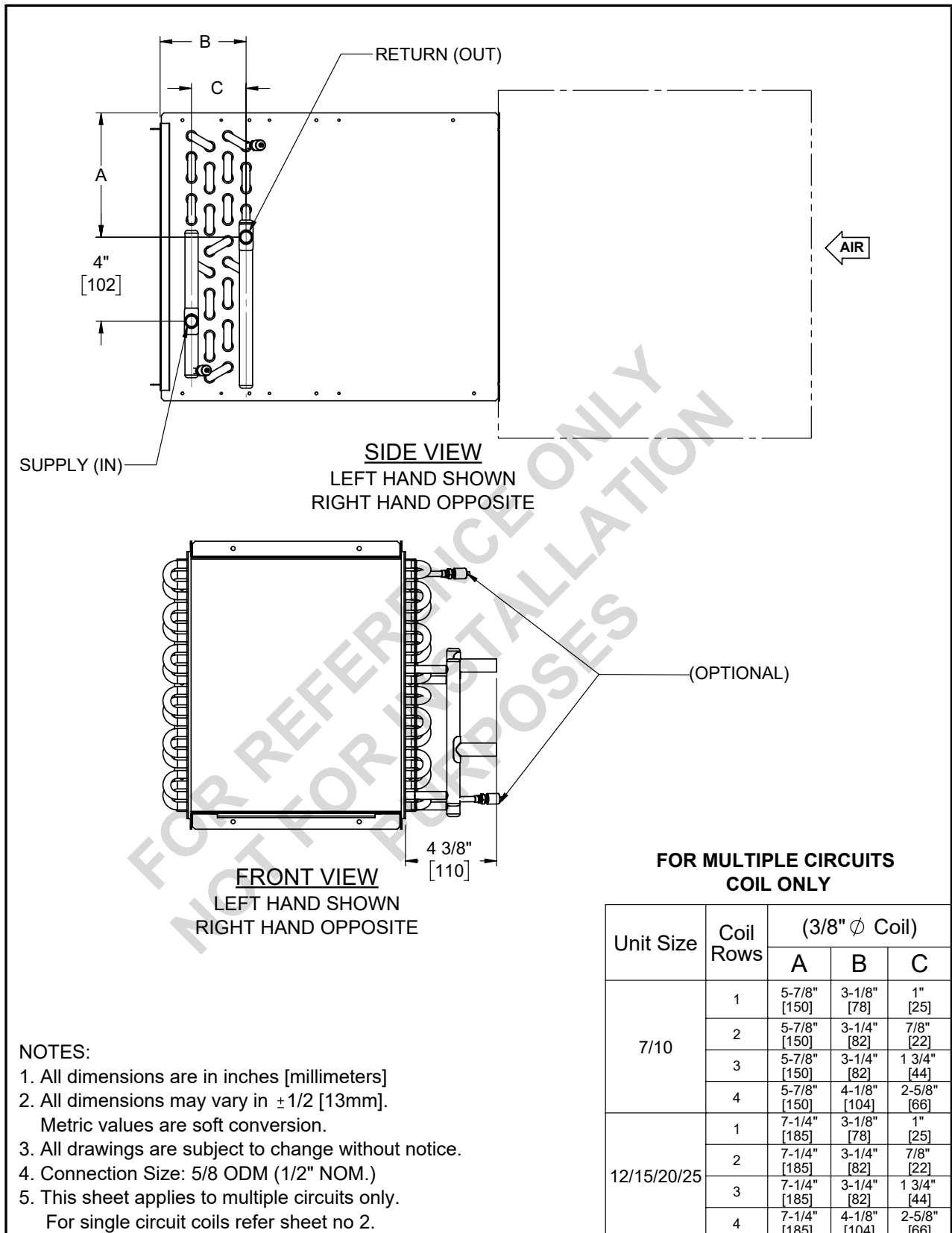

NOTES:

1. All dimensions are in inches [millimeters]
2. All dimensions may vary in $\pm 1/2$ [13mm].
Metric values are soft conversion.
3. All drawings are subject to change without notice.
4. Connection Size: 5/8 ODM (1/2" NOM.)
5. This sheet applies to multiple circuits only.
For single circuit coils refer sheet no 2.

MODEL CRB AND CRQ SIZES 07-25

1/2" Hot Water Coil Connections, Single Circuit

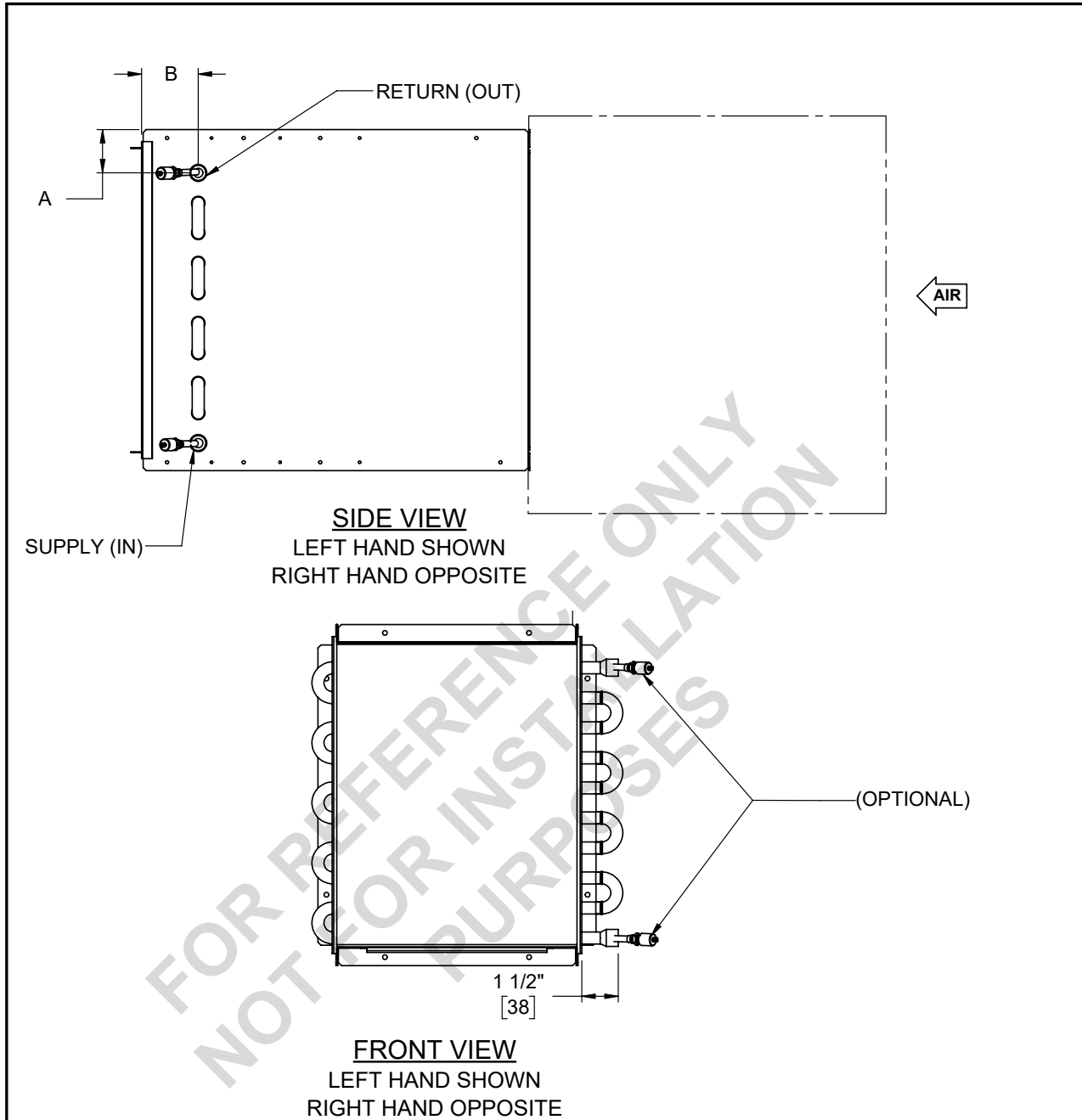

NOTES:

1. All dimensions are in inches [millimeters]
2. All dimensions may vary in $\pm 1/2$ [13mm].
Metric values are soft conversion.
3. All drawings are subject to change without notice.
4. Connection Size: 5/8 ODM (1/2" NOM.)
5. This sheet applies to single circuit coils only.
For multiple circuit coils refer sheet no 1.
For two row two circuit coils refer sheet no 3.

SINGLE CIRCUIT COILS ONLY

Unit Size	Coil Rows	No. of Circuits	(1/2" ϕ Coil)	
			A	B
7/10	1	1	1-3/4" [46]	2-3/8" [60]
	2	1	1-1/8" [30]	3-1/2" [87]
	3	1	1-1/8" [30]	3-1/2" [87]
12/15/20/25	1	1	1-3/4" [46]	2-3/8" [60]

MODEL CRB AND CRQ SIZES 07-15

1/2" Hot Water Coil Connections, Two Row, Two Circuit

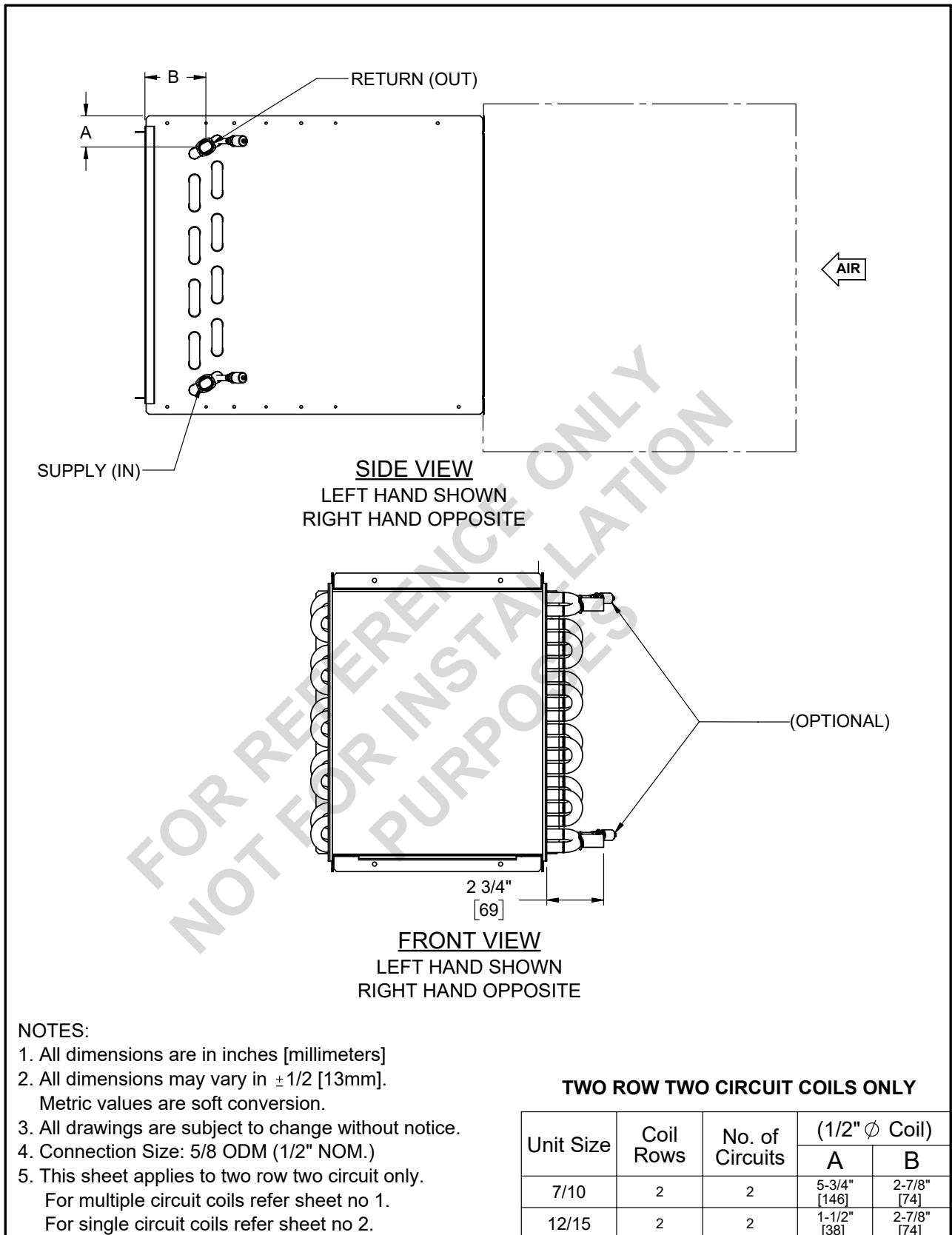

MODEL CRB AND CRQ SIZES 07-25

1/2" Hot Water Coil Connections, Multiple Circuits

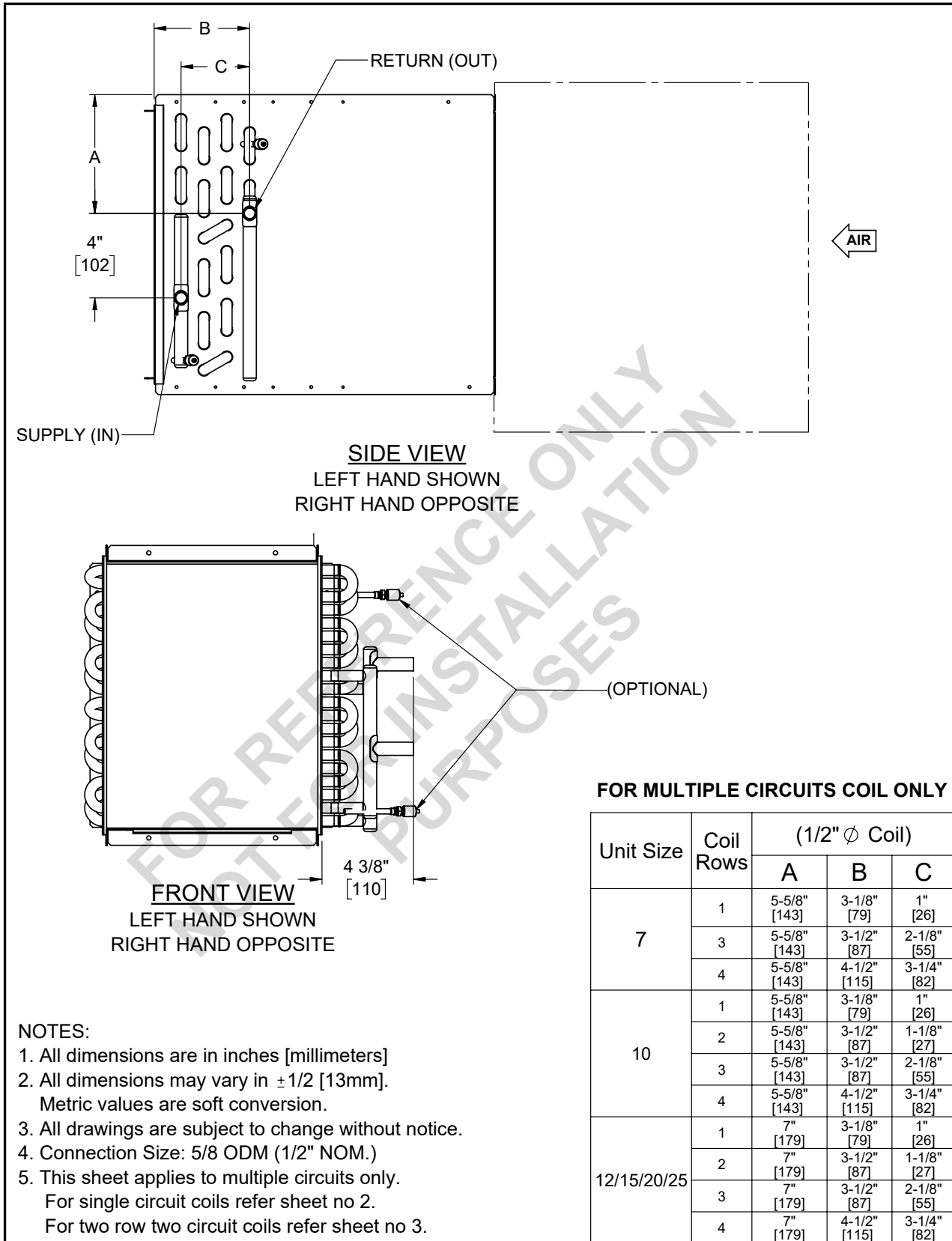

NOTES:

1. All dimensions are in inches [millimeters]
2. All dimensions may vary in $\pm 1/2$ [13mm].
Metric values are soft conversion.
3. All drawings are subject to change without notice.
4. Connection Size: 5/8 ODM (1/2" NOM.)
5. This sheet applies to multiple circuits only.
For single circuit coils refer sheet no 2.
For two row two circuit coils refer sheet no 3.

MODEL CRB AND CRQ SIZES 07-25 3/8" Valve Package Connections

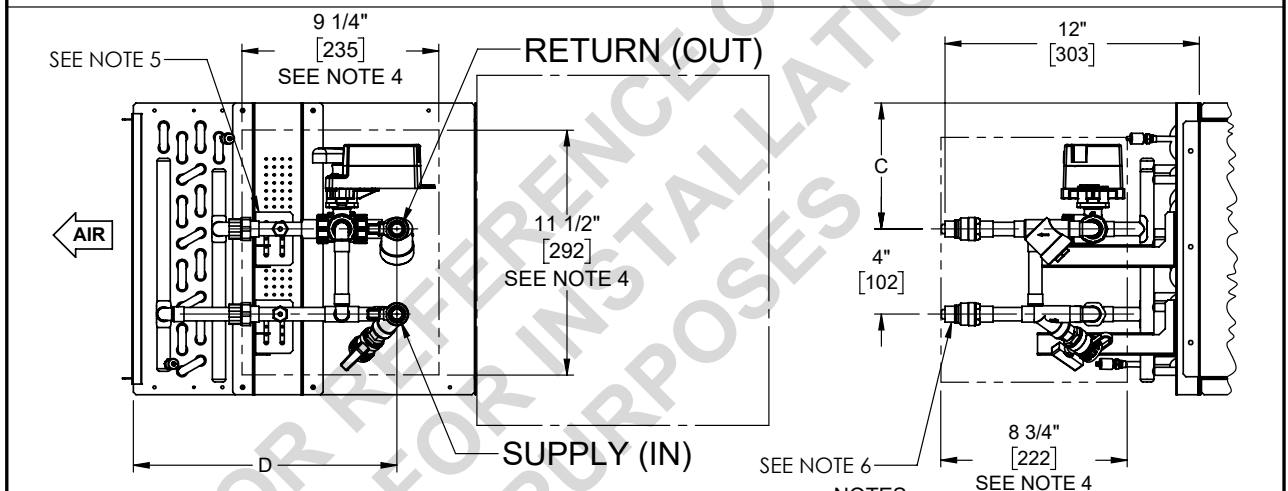
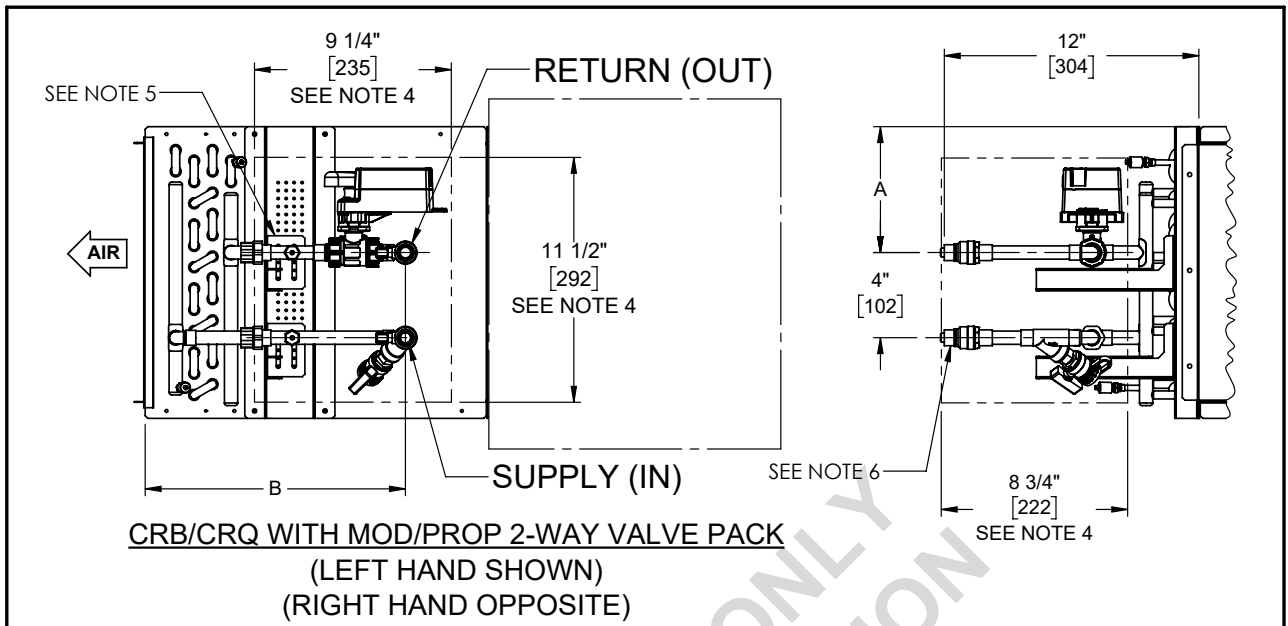

NOTES:

1. All dimensions are in inches [millimeters]
All dimensions may have ±1/2 [13mm] variation.
Metric values are soft conversion.
2. All drawings subject to change without notice.
3. Consult unit selection summary for valve package components and specifications. Valve package end point dimensions are fixed value, regardless of selected valve package components.
4. Dimensions indicate space requirement for valve-package install. Additional service space requirements depend on option selections.
5. Valve package support structure can be removed.
6. SS flexible hoses are available but not shown.

UNIT SIZE	COIL ROWS	A	B	C	D
07/10	1/2/3	5-15/16" [151]	12-5/8" [324]	5-15/16" [151]	12-7/8" [327]
	4	5-15/16" [151]	12-1/4" [311]	5-15/16" [151]	12-3/8" [314]
12/15/20/25	1/2/3	7-5/16" [186]	12-5/8" [324]	7-5/16" [186]	12-7/8" [327]
	4	7-5/16" [186]	12-1/4" [311]	7-5/16" [186]	12-3/8" [314]

MODEL CRB AND CRQ SIZES 07-25 3/8" Valve Package Connections

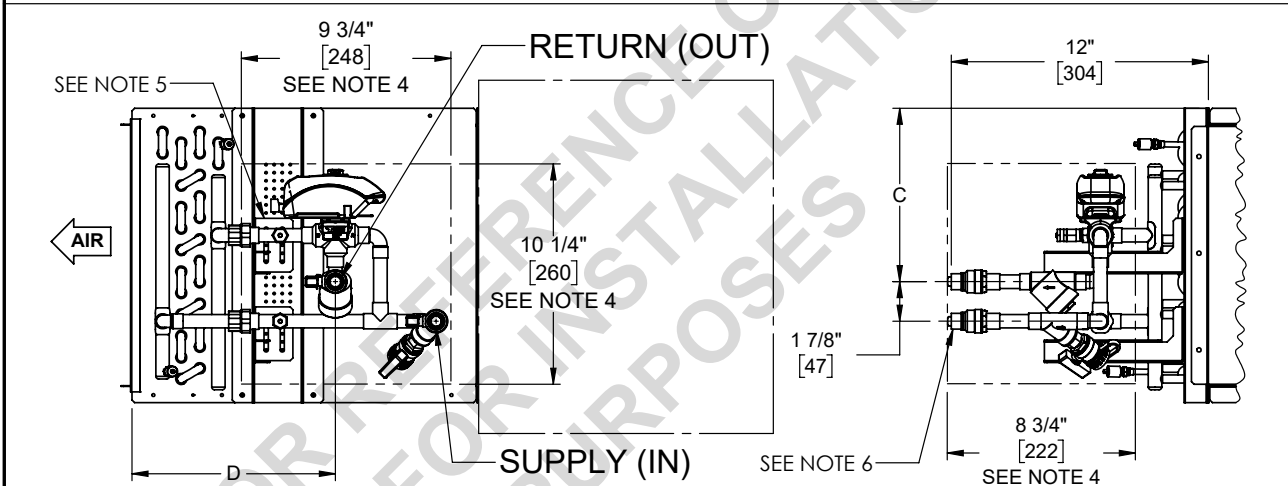
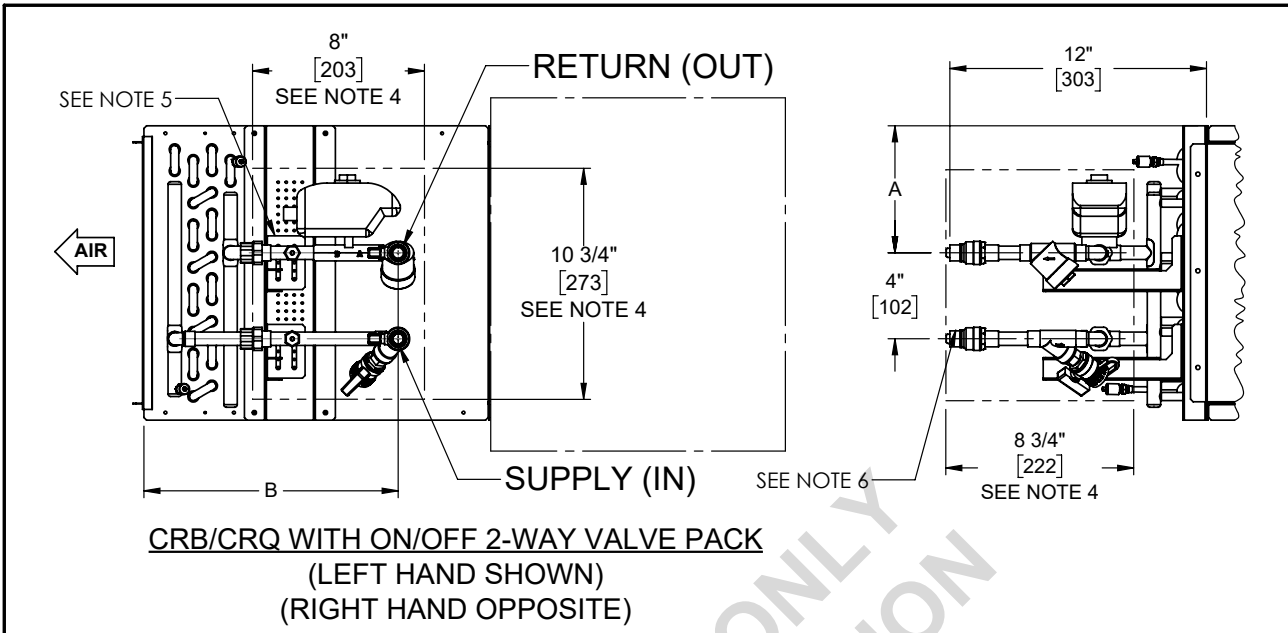

NOTES:

1. All dimensions are in inches [millimeters]. All dimensions may have ±1/2 [13mm] variation. Metric values are soft conversion.
2. All drawings subject to change without notice.
3. Consult unit selection summary for valve package components and specifications. Valve package end point dimensions are fixed value, regardless of selected valve package components.
4. Dimensions indicate space requirement for valve-package install. Additional service space requirements depend on option selections.
5. Valve package support structure can be removed.
6. SS flexible hoses are available but not shown.

UNIT SIZE	COIL ROWS	A	B	C	D
07/10	1/2/3	5-15/16" [151]	12-3/8" [314]	8-1/8" [206]	10" [254]
	4	5-15/16" [151]	11-7/8" [311]	8-1/8" [206]	9-1/2" [241]
12/15/20/25	1/2/3	7-5/16" [186]	12-3/8" [314]	9-1/2" [240]	10" [254]
	4	7-5/16" [186]	11-7/8" [311]	9-1/2" [240]	9-1/2" [241]

MODEL CRB AND CRQ SIZES 07-25 3/8" Valve Package Connections

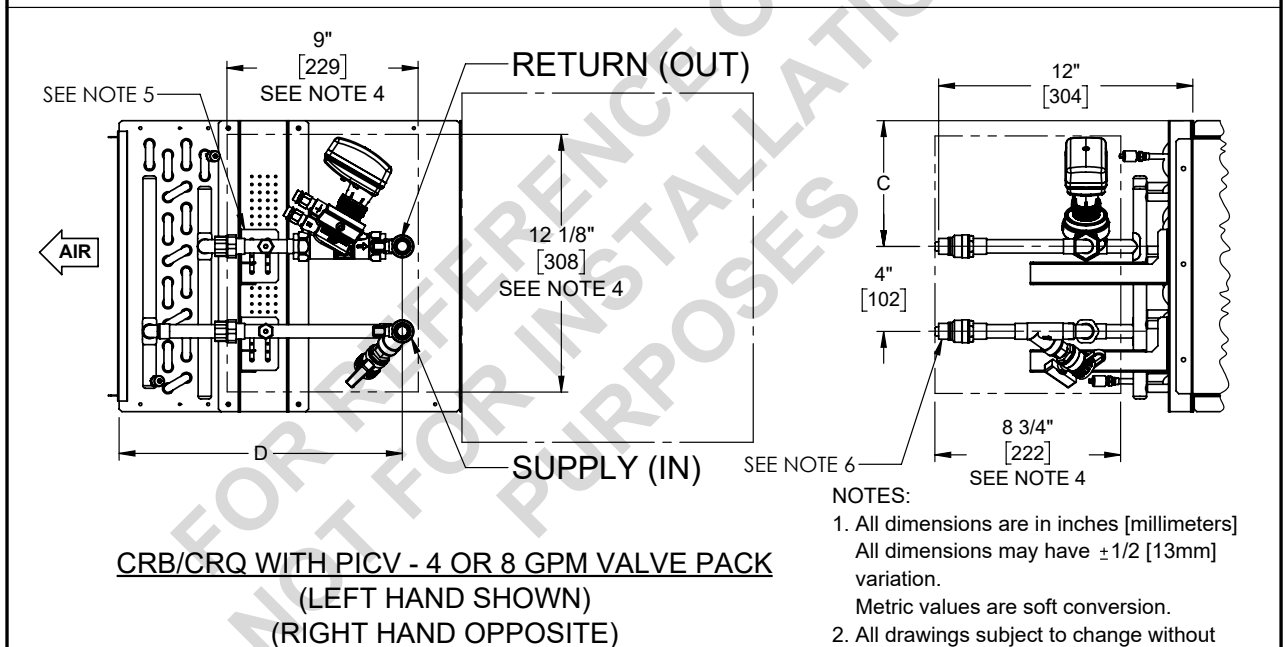
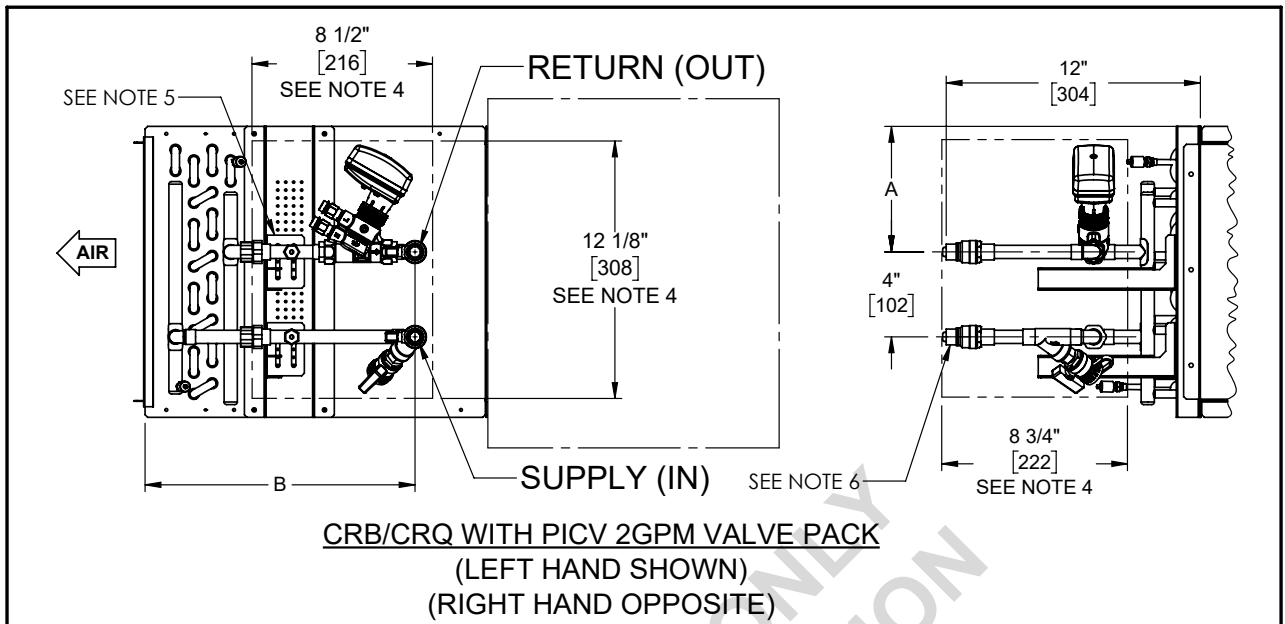

NOTES:

1. All dimensions are in inches [millimeters]
All dimensions may have ±1/2 [13mm] variation.
Metric values are soft conversion.
2. All drawings subject to change without notice.
3. Consult unit selection summary for valve package components and specifications. Valve package end point dimensions are fixed value, regardless of selected valve package components.
4. Dimensions indicate space requirement for valve-package install. Additional service space requirements depend on option selections.
5. Valve package support structure can be removed.
6. SS flexible hoses are available but not shown.

UNIT SIZE	COIL ROWS	A	B	C	D
07/10	1/2/3	5-15/16" [151]	13-1/4" [337]	5-15/16" [151]	13-7/8" [353]
	4	5-15/16" [151]	12-3/4" [324]	5-15/16" [151]	13-3/8" [340]
12/15/20/25	1/2/3	7-5/16" [186]	13-1/4" [337]	7-5/16" [186]	13-7/8" [353]
	4	7-5/16" [186]	12-3/4" [324]	7-5/16" [186]	13-3/8" [340]

MODEL CRB AND CRQ SIZES 07-25 1/2" Valve Package Connections

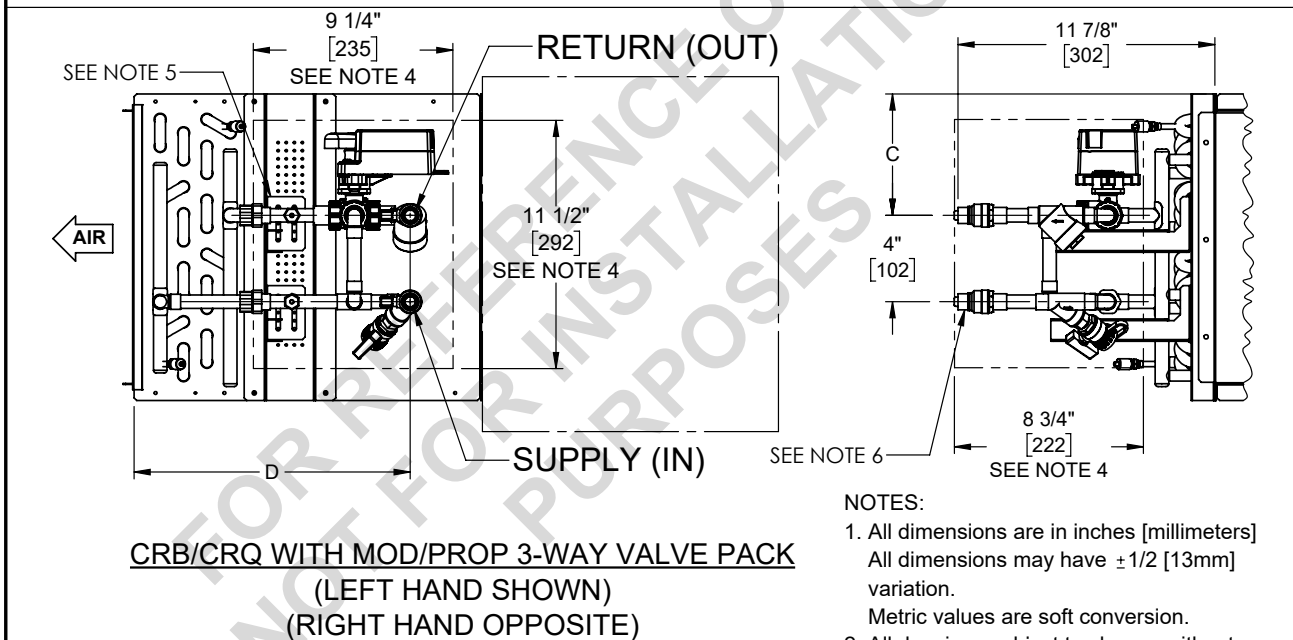
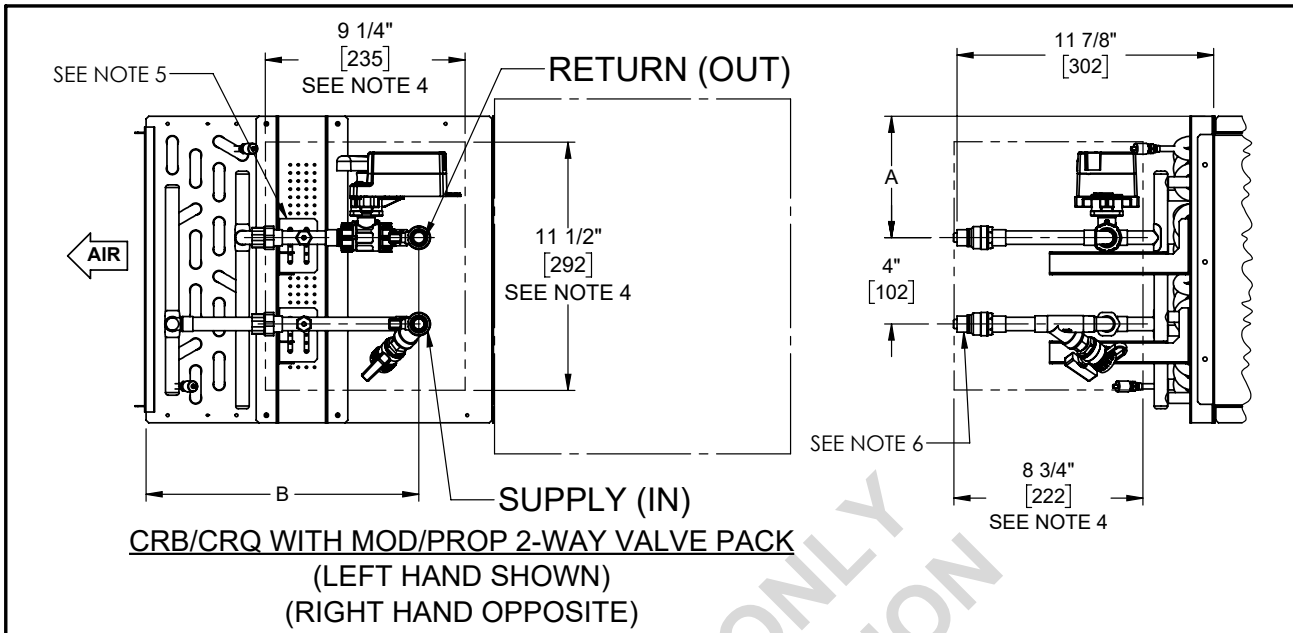

NOTES:

1. All dimensions are in inches [millimeters]
All dimensions may have ±1/2 [13mm] variation.
Metric values are soft conversion.
2. All drawings subject to change without notice.
3. Consult unit selection summary for valve package components and specifications. Valve package end point dimensions are fixed value, regardless of selected valve package components.
4. Dimensions indicate space requirement for valve-package install. Additional service space requirements depend on option selections.
5. Valve package support structure can be removed.
6. SS flexible hoses are available but not shown.

UNIT SIZE	COIL ROWS	A	B	C	D
07/10	1/2/3	5-5/8" [143]	12-7/8" [329]	5-5/8" [143]	13-1/8" [333]
	4	5-5/8" [143]	12-5/8" [321]	5-5/8" [143]	12-3/4" [325]
12/15/20/25	1/2/3	7-1/16" [179]	13" [331]	7-1/16" [179]	13" [331]
	4	7-1/16" [179]	12-5/8" [321]	7-1/16" [179]	12-3/4" [325]

MODEL CRB AND CRQ SIZES 07-25 1/2" Valve Package Connections

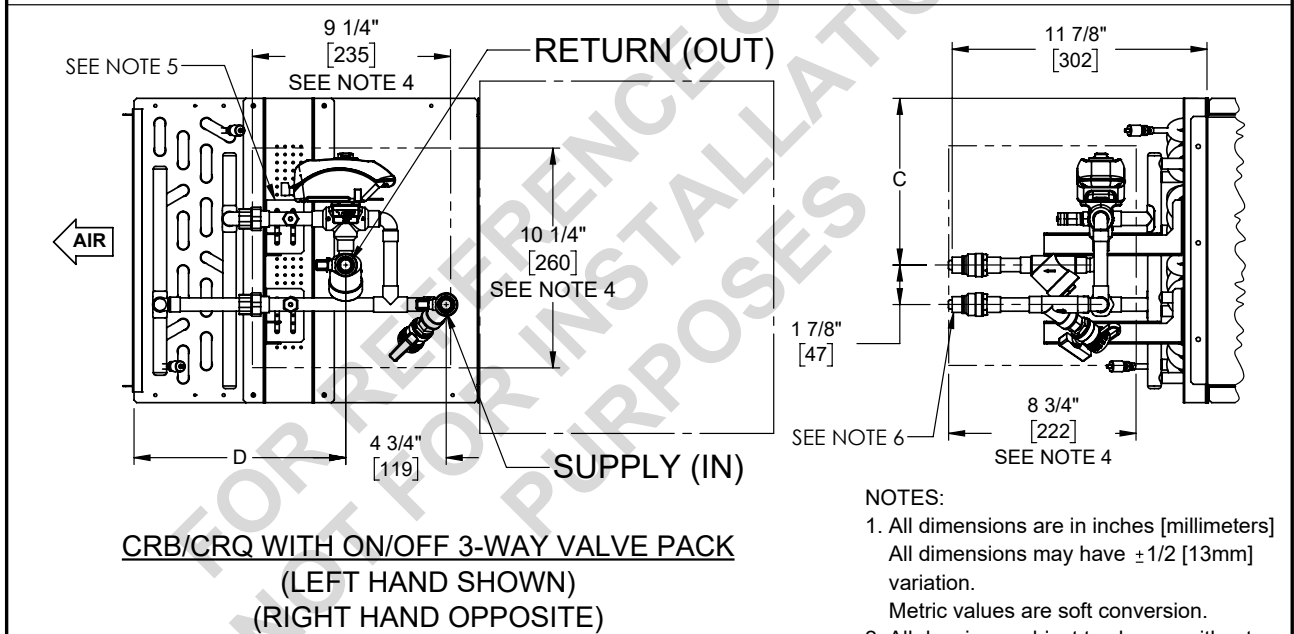
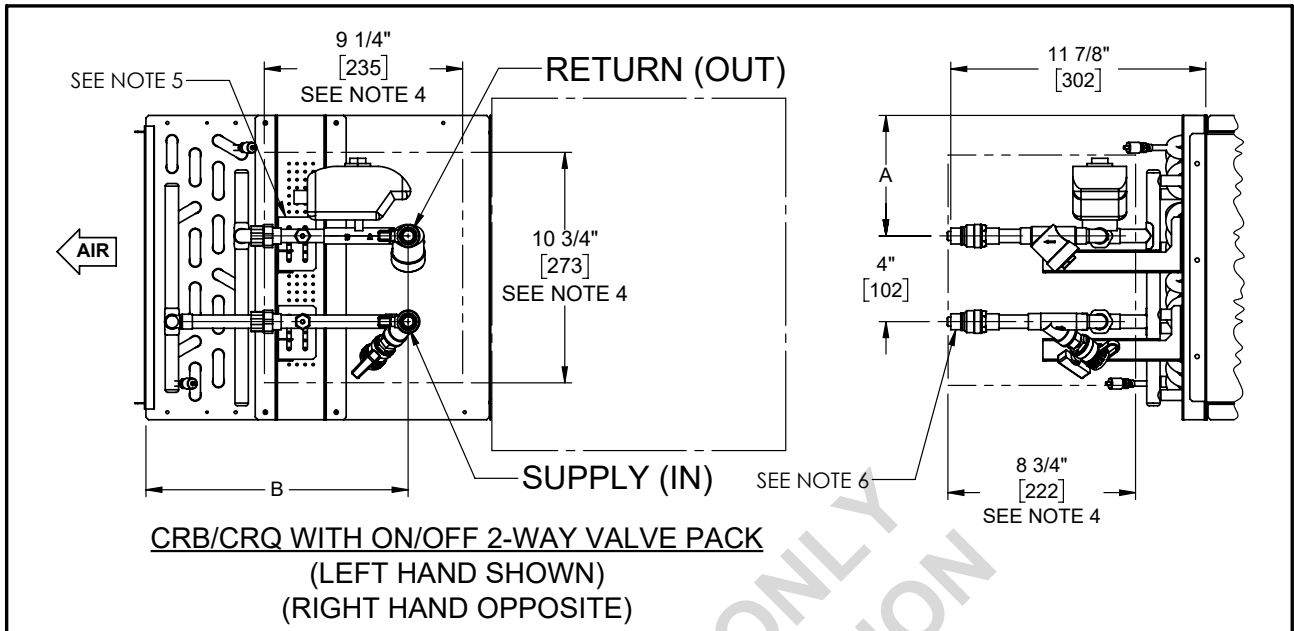

- NOTES:**
1. All dimensions are in inches [millimeters]. All dimensions may have ±1/2 [13mm] variation. Metric values are soft conversion.
 2. All drawings subject to change without notice.
 3. Consult unit selection summary for valve package components and specifications. Valve package end point dimensions are fixed value, regardless of selected valve package components.
 4. Dimensions indicate space requirement for valve-package install. Additional service space requirements depend on option selections.
 5. Valve package support structure can be removed.
 6. SS flexible hoses are available but not shown.

UNIT SIZE	COIL ROWS	A	B	C	D
07/10	1/2/3	5-5/8" [143]	12-1/2" [319]	7-3/4" [198]	10-1/8" [259]
	4	5-5/8" [143]	12-1/4" [311]	7-3/4" [198]	9-7/8" [251]
12/15/20/25	1/2/3	7-1/16" [179]	12-1/2" [319]	9-1/2" [233]	10-1/8" [259]
	4	7-1/16" [179]	12-1/4" [311]	9-1/2" [233]	9-7/8" [251]

MODEL CRB AND CRQ SIZES 07-25

1/2" Valve Package Connections

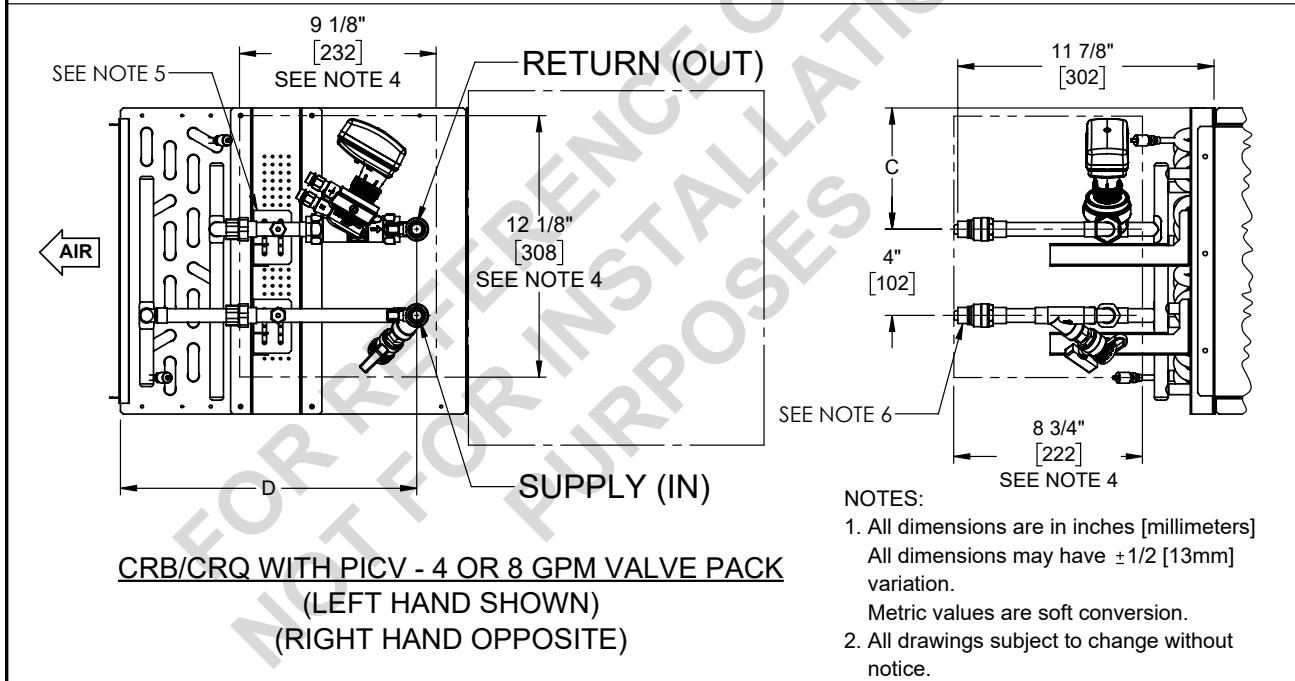
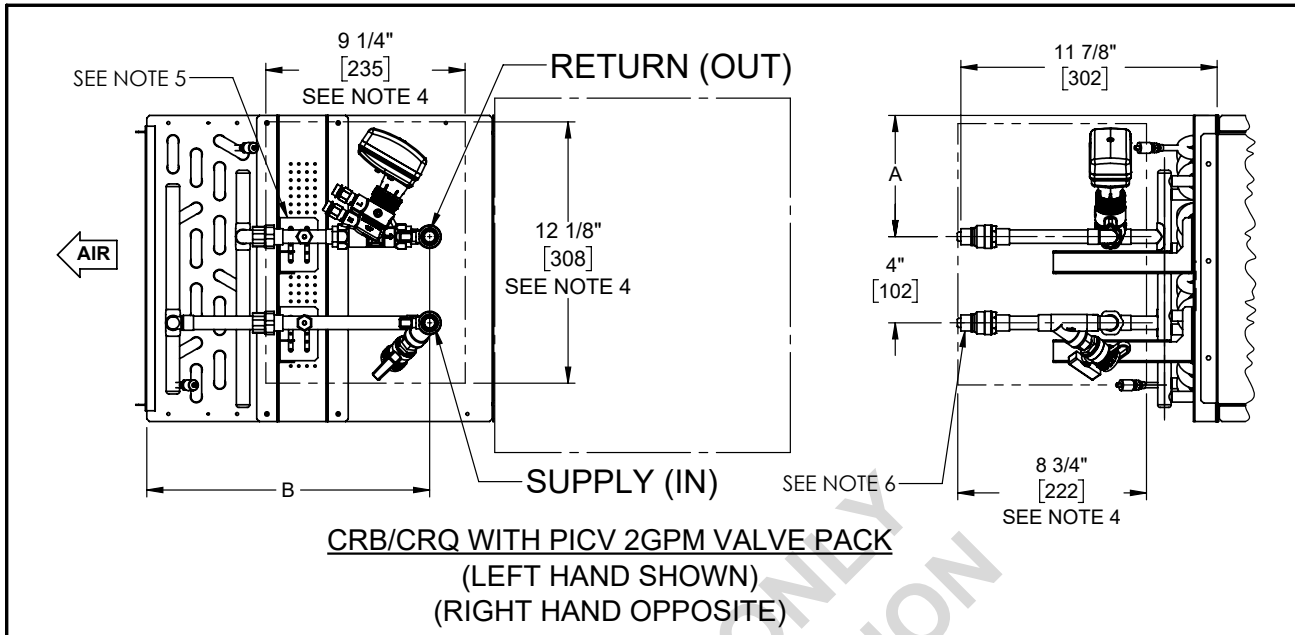

- NOTES:**
1. All dimensions are in inches [millimeters]
All dimensions may have ±1/2 [13mm] variation.
Metric values are soft conversion.
 2. All drawings subject to change without notice.
 3. Consult unit selection summary for valve package components and specifications. Valve package end point dimensions are fixed value, regardless of selected valve package components.
 4. Dimensions indicate space requirement for valve-package install. Additional service space requirements depend on option selections.
 5. Valve package support structure can be removed.
 6. SS flexible hoses are available but not shown.

UNIT SIZE	COIL ROWS	A	B	C	D
07/10	1/2/3	5-5/8" [143]	13-3/8" [341]	5-5/8" [143]	14" [357]
	4	5-5/8" [143]	13-1/8" [333]	5-5/8" [143]	13-3/4" [349]
12/15/20/25	1/2/3	7-1/16" [179]	13-3/8" [341]	7-1/16" [179]	14" [357]
	4	7-1/16" [179]	13-1/8" [333]	7-1/16" [179]	13-3/4" [349]

INSPECTION & START-UP CHECKLIST

(BASED ON UNIT CONFIGURATION, SOME CHECKLIST ITEMS MAY NOT BE APPLICABLE)

1. RECEIVING AND INSPECTION

- Unit Received Undamaged
- Unit Arrangement/Hand Correct
- Unit Received Complete as Ordered
- Unit Structural Support Complete & Correct

2. HANDLING AND INSTALLATION

- Unit Mounted Level & Square
- Proper Electrical Service Provided
- Proper Service Switch/Disconnect Provided
- Proper Access Provided For Unit & Accessories
- Proper Overcurrent Protection Provided
- Proper Chilled Water Line Size to Unit
- Proper Hot Water Line to Unit
- All Services to Unit in Code Compliance
- All Shipping Screws & Braces Removed

3. COOLING/HEATING CONNECTIONS

- Protect Valve Package Components From Heat
- Connect Field Piping to Unit
- Install Drain Pan as Required
- Install Condensate Pan Under Piping as Required
- Mount, Secure, and Support Valve Packages
- Pressure Test All Piping for Leaks
- Insulate All Piping as Required
- Connect Supply and Return Pipe to Correct Coil Connections

4. DUCTWORK CONNECTIONS

- Install Ductwork, Fittings & Grilles as Required
- Proper Supply/Return Grille Types & Sizes Used
- Insulate All Ductwork as Required

5. ELECTRICAL CONNECTIONS

- Refer to Unit Wiring Diagram
- All Field Wiring in Code Compliance
- Connect Incoming Power Service or Services
- SCR Fan Speed Control Wired to Low Speed
- Tighten All Electrical Connections Prior To Start-Up

6. UNIT STARTUP

- General Visual Unit & System Inspection
- Record Ambient Temperature
- Close All Unit Isolation Valves
- All Ductwork & Grilles in Place
- Start Fans, Etc.
- Check All Ductwork & Units for Air Leaks
- Record All Final Settings for Future Use
- Check All Dampers for Proper Operation
- Verify Proper Heating Operation
- Verify Proper Cooling Operation
- Record Electrical Supply Voltage
- Check All Wiring for Secure Connections
- Vent Water Systems as Required
- All Unit Panels & Filters In Place
- Check for Overload Condition of All Units
- Balance Air Systems as Required
- Check Piping & Ductwork for Vibration
- Verify Proper Cooling Operation
- Reinstall All Covers & Access Panels

MAINTENANCE

Factory Provided Damper Actuator

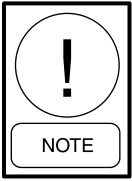

Equipment may be supplied with a field or factory mounted damper actuator. If actuator is field or factory-provided, refer to the actuator IOM for specific instructions. See Table 1 for maximum wire lengths for control voltage.

TABLE 1 - MAXIMUM WIRE LENGTHS	
WIRE SIZE	MAX FEET
16 GA	1225 FT
18 GA	725 FT
20 GA	400 FT
22 GA	200FT

Damper Shaft

There is an indicator on the end of the damper shaft that can be used to determine the position on the damper blade. If the indicator is horizontal, the damper is completely open.



Damper shaft indicator in horizontal position, indicating fully open damper blade

Motor/Blower Assembly

Fan-powered terminal unit motors are equipped with permanently lubricated bearings and require little or no maintenance. The frequency of required cleaning is dependent on the operating hours of the system, filter maintenance and efficiency, as well as dirt load. Periodically inspect the motor and blower housing wheel for accumulation of dust, and clean as necessary.

Motor/Blower Cleaning

1. Disconnect all electrical power to the equipment, lock out and tag out power source.
2. Gain access to motor housing through top or bottom access panels, using a slotted screwdriver or similar tool to turn latches.
3. Use soft brush and vacuum to remove loose debris from motor housing.
4. Replace access panel(s) and restore electrical power to equipment.
5. Use caution to assure that any contaminated material does not contact other areas of the equipment or building. **Properly dispose of all contaminated materials.**

Motor/Blower Removal And Replacement



ELECTRICAL SHOCK HAZARDS
All power must be disconnected prior to installation and servicing this equipment. More than one source of power may be present. Disconnect, lock out and tag out all power sources to avoid electrocution or shock hazards.



Step 1: Disconnect all electrical power to the equipment, lock out and tag out power source. Locate top or bottom panel quarter-turn latches, turn counter-clockwise to disengage.

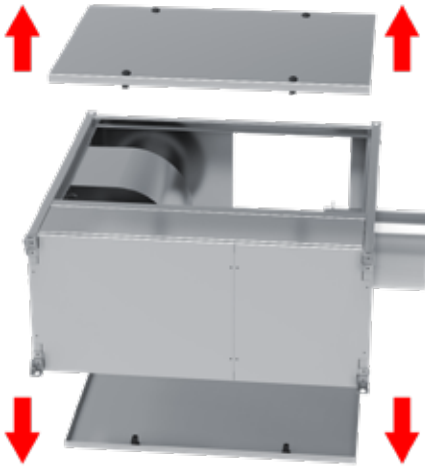

Step 2: With quarter-turn latches in the unlocked position, remove access panels from unit, and place in a secure location. Disconnect fan motor wiring.



Step 3: Locate and remove all hardware securing the fan assembly to the unit chassis. Carefully remove the fan assembly from its installed position, loosen fan wheel set screw.



Step 4: Locate and remove the bolts securing the motor to the fan housing. Remove motor/belly band, perform motor/blower maintenance as required. To reassemble and reinstall motor/blower assembly, follow steps 1-4 in reverse fashion.

Coil

The frequency of required cleaning is dependent on the operating hours of the system, filter maintenance and efficiency as well as dirt load.

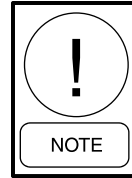

Important: Coils may become externally fouled as result of normal operation. Dirt on the surface of the coil reduces its ability to transfer heat that can result in reduced performance and increased operating energy cost. If the dirt on the surface of the coil becomes wet, microbial growth can result, possibly causing unpleasant odors and serious health related indoor air quality problems.



Fin edges are sharp. Fins are fragile; care must be exercised to avoid damaging fins. Do not use solutions to clean coils; drain pans are not present to remove collected solution.

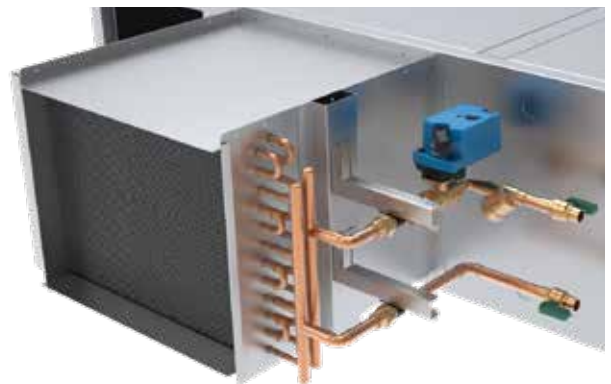

Coil Cleaning

1. Disconnect all electrical power to the equipment, lock out and lock out power source.
2. Put on appropriate personal protective equipment.
3. Gain access to coil either through ductwork or optional coil access panel.
4. Use soft brush and vacuum to remove loose debris from sides of coil.
5. Straighten any coil fins that may have been damaged during cleaning process with fin comb.
6. Replace ductwork or access panel and restore electrical power to equipment.
7. Use caution to assure that any contaminated material does not contact other areas of the equipment or building. **Properly dispose of all contaminated materials.**

Coil Replacement

1. Disconnect all electrical power to the equipment, lock out and tag out power source.
2. Disconnect all ductwork, if applicable.
3. Remove filter rails/ filter clips, if applicable.
4. Drain water from coil.
5. Cut or un-braze water connection at coil.
6. Disconnect coil from equipment by removing screws on the exterior perimeter of the coil.
7. To reinstall coil, follow steps 1-5 in reverse fashion

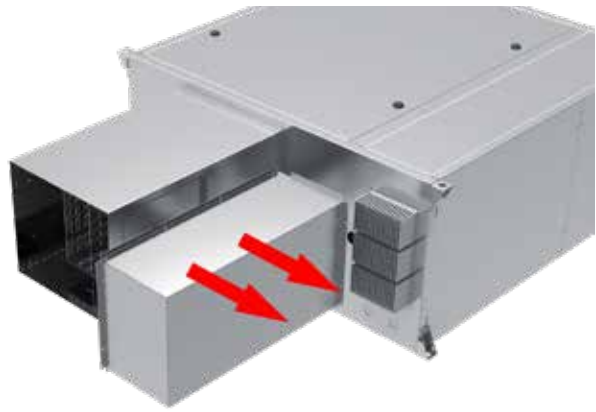

Electric Heat

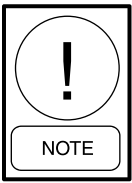

Electric heat requires a minimum of 0.1" W.G. downstream static pressure for proper operation.

Electric heaters come equipped with a primary auto-reset limit switch to provide protection against overheating. The primary auto-reset limit switch automatically cuts the heater off when overheating occurs, and turns the heater back on when the elements have cooled down. Should the secondary manual reset limit switch trip, it can be reset by way of the push button. Electric heaters may be equipped with optional disconnect switch, fuses and airflow proving switch.

Electric Heat Replacement



Step 1: Disconnect all electrical power to the equipment, lock out and tag out power source. Locate electric heat wiring harness cover on the side of the discharge duct.

Step 2: Remove screws securing electric heat wiring harness cover. Remove cover from unit and set aside. Disconnect visible wiring harness.

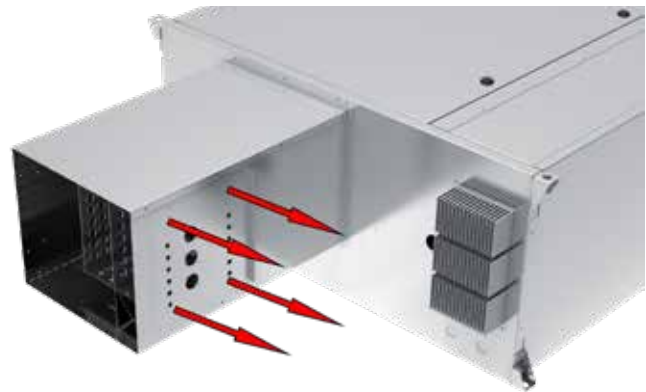

Step 3: Remove the four (4) screws securing the electric heat t-plate to the side of discharge duct. Carefully slide electric heat rack out and away from the discharge duct.

Step 4: Perform electric heat rack maintenance or replacement as required. To reinstall, perform steps 1-3 in reverse fashion. Ensure all electric control enclosure panels are properly secured in place before applying power to the unit.

Filters

This unit may be equipped with an optional 1" or 2" throwaway filter, which should be replaced on a regular basis. The time interval between each replacement should be established based on regular inspection of the filter, and should be recorded in the log for each unit. At a minimum, filters should be inspected monthly and replaced if needed. Refer to the Filters Chart for recommended filter size for each product type and size.

If the replacement filters are not purchased from the factory, the filters used should be the same type, size and MERV rating as that furnished from or recommended by the factory.

Optional 1" and 2" pleated filters are available and can be used in this unit. Changing filter thickness and type can change static pressure. Contact the local Sales Representative for the correct filter upgrade specification and availability.

Filter Replacement

The optional filter is held in place by three (3) filter clips. To replace the filter, rotate the filter clips 180-degrees, and pull the filter away from the unit. Replace with a new filter, and once in place, rotate the filter clips 180-degrees back to their original position.

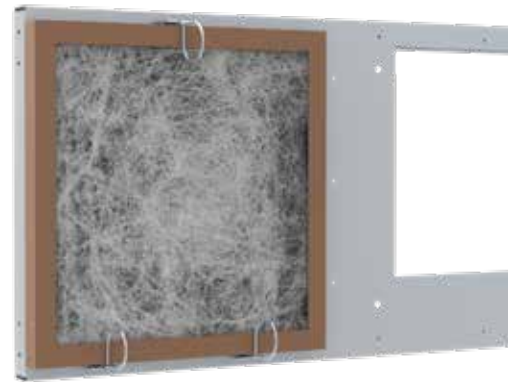

Optional filter and filter clip assembly

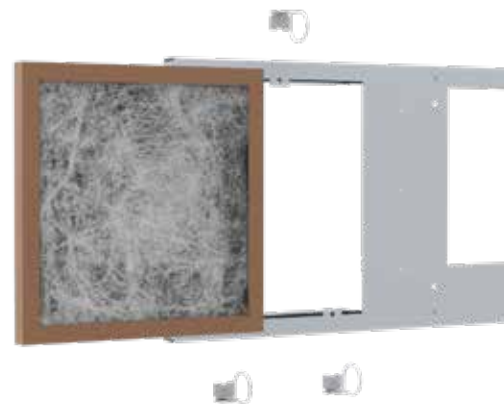

Tool-free removable filter clips allow for use of 1" or 2" filter sizes

FACE AREA, FREE AREA, AND FILTER SIZES

THROWAWAY 1" & 2" FILTERS

UNIT SIZE	HEATING COIL FACE AREA	NOMINAL FILTER SIZES	1" THROWAWAY FACE AREA	2" THROWAWAY FACE AREA
07	0.83 [0.08]	(1) 14 x 14 [356 x 356]	1.27 [0.12]	1.27 [0.12]
10	1.33 [0.12]	(1) 14 x 14 [356 x 356]	1.27 [0.12]	1.27 [0.12]
12	2 [0.19]	(1) 18 x 20 [457 x 508]	2.37 [0.22]	2.37 [0.22]
15	2 [0.19]	(1) 18 x 20 [457 x 508]	2.37 [0.22]	2.37 [0.22]
20	2.67 [0.25]	(1) 18 x 20 [457 x 508]	2.37 [0.22]	2.37 [0.22]
25	2.67 [0.25]	(1) 20 x 18 [508 x 457]	2.37 [0.22]	2.37 [0.22]

PLEATED 1" & 2" MERV 8 FILTERS

UNIT SIZE	HEATING COIL FACE AREA	NOMINAL FILTER SIZES	1" PLEATED MERV 8 GROSS MEDIA AREA	2" PLEATED MERV 8 GROSS MEDIA AREA
07	0.83 [0.08]	(1) 14 x 14 [356 x 356]	2.3 [0.21]	4 [0.37]
10	1.33 [0.12]	(1) 14 x 14 [356 x 356]	2.3 [0.21]	4 [0.37]
12	2 [0.19]	(1) 18 x 20 [457 x 508]	4.3 [0.4]	7 [0.65]
15	2 [0.19]	(1) 18 x 20 [457 x 508]	4.3 [0.4]	7 [0.65]
20	2.67 [0.25]	(1) 18 x 20 [457 x 508]	4.3 [0.4]	7 [0.65]
25	2.67 [0.25]	(1) 20 x 18 [508 x 457]	4.3 [0.4]	7 [0.65]

PLEATED 1" & 2" MERV 13 FILTERS

UNIT SIZE	HEATING COIL FACE AREA	NOMINAL FILTER SIZES	1" PLEATED MERV 13 GROSS MEDIA AREA	2" PLEATED MERV 13 GROSS MEDIA AREA
07	0.83 [0.08]	(1) 14 x 14 [356 x 356]	2.9 [0.27]	5.6 [0.52]
10	1.33 [0.12]	(1) 14 x 14 [356 x 356]	2.9 [0.27]	5.6 [0.52]
12	2 [0.19]	(1) 18 x 20 [457 x 508]	5.3 [0.49]	10 [0.93]
15	2 [0.19]	(1) 18 x 20 [457 x 508]	5.3 [0.49]	10 [0.93]
20	2.67 [0.25]	(1) 18 x 20 [457 x 508]	5.3 [0.49]	10 [0.93]
25	2.67 [0.25]	(1) 20 x 18 [508 x 457]	5.3 [0.49]	10 [0.93]

NOTES:

1. All filters are an optional feature. For optimal unit performance, filter type should be selected during the unit selection and ordering process.
2. Filter sizes are nominal, measured in inches [millimeters]
3. Coil and filter face areas are measured in square feet [square meters]

GENERAL TROUBLESHOOTING GUIDELINES

FOR COMPONENT-SPECIFIC TROUBLESHOOTING, REFER TO THE COMPONENT IOM APPENDIX ON P. 36

TROUBLESHOOTING GUIDELINES		
PROBLEM	POSSIBLE CAUSE	CORRECTIVE ACTION
Motor Fails to Start	Blown fuse or open circuit breaker	Replace fuse or reset circuit breaker; verify and correct source of overload.
	Shipping Cardboard insert in fan wheel	Remove insert and restart
	Improper wiring connections	Check wiring with diagram supplied on unit
	Improper current supply	Compare actual supply power with motor nameplate recommendations. Contact power company for adjustments.
	Mechanical failure	Check motor and confirm rotates freely
Motor Overheats	Fan motor is clogged with dirt, preventing proper ventilation	Remove fan cover, clean fan and replace cover. It may be necessary to replace the fan motor.
	Lack of required external static pressure	Add required external static pressure
Motor/Blower Operating In Reverse	Fan motor not energized prior to introduction of air through primary air valve	Energize fan motor prior to introducing air through primary air valve
Excessive Motor Noise	Motor mounting bolts loose	Tighten motor mounting bolts
	Fan wheel rubbing on fan housing	Align wheel in housing
	Loose fan wheel	Align and tighten
	Motor SCR set too low	Readjust motor speed SCR
Low Coil Capacity	Incorrect airflow	Check fan operating conditions
	Incorrect GPM	Check water pumps, valves and lines for obstructions
	Dirty coil fins	Clean coil fins
	Dirty filter (where applicable)	Replace filter
	Incorrect water temperature	Provide proper water temperature
Heater Does Not Operate	No Power	Check disconnect switch
	No Control Voltage	Check transformer and transformer fusing (if applicable). Replace if necessary.
	Blown Fuse	Replace fuse
	Open Limit (primary or secondary)	Replace limits or reset as applicable
		Check for continuity across limit to determine if open, replace as necessary
	Airflow Incorrect Direction	Check sensing tube, red tube = high and black tube = low, rotate if needed. Check for kinks, replace if needed
	Low External Static Pressure	Increase airflow to obtain a minimum of .1 in. w.c. external static
	Damaged elements	Check for open or damaged elements and replace as necessary
Low or High Temperature Rise	Incompatible Thermostat or Controller	Check wiring
		Check for compatibility
	Problems with Additional Stages	Check location of thermostat; might be installed in a "too hot" or "too cold" location. Check heat outputs on controller
		Check contactors for open coil
		Check for damaged elements
Incorrect CFM	Check for blocked duct or location of heater	
Heater with SSR Does Not Operate	Incorrect Signal Applied	Verify signal input
	Interface Board Fuse Blown	Replace fuse

VALVE CALIBRATION CHARTS

APPLICABLE CALIBRATION CHARTS ARE AFFIXED TO EACH UNIT AND MAY ALSO BE DOWNLOADED FROM THE ENVIRO-TEC WEBSITE AT WWW.ENVIRO-TEC.COM

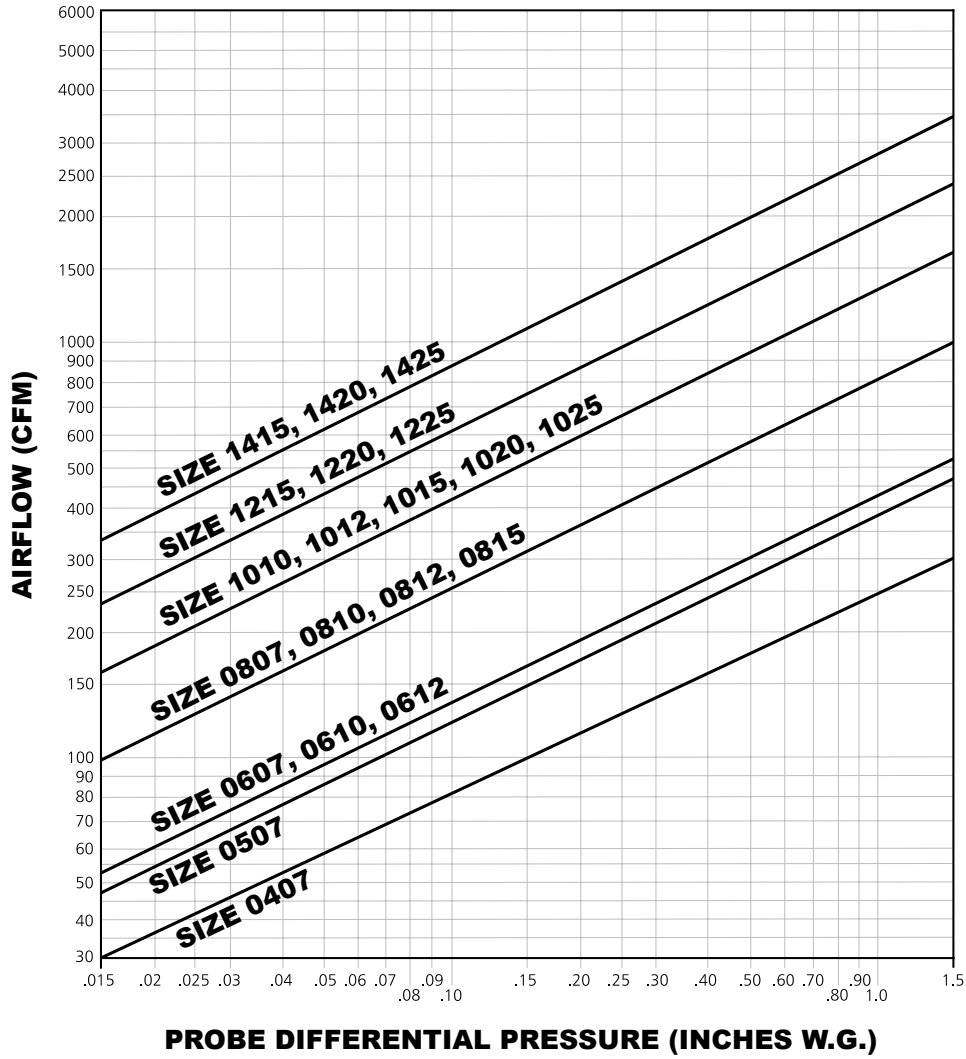

FAN CFM CALIBRATION CURVE EXAMPLES

APPLICABLE CALIBRATION CURVES ARE AFFIXED TO EACH UNIT. CALIBRATION CURVES SHOWN BELOW ARE FOR EC MOTOR ONLY

SERIES FLOW FAN POWERED FAN SIZE 10
 FAN CALIBRATION CURVE: 1-PHASE CONSTANT-TORQUE EC MOTOR
 No Filter, Fan Only

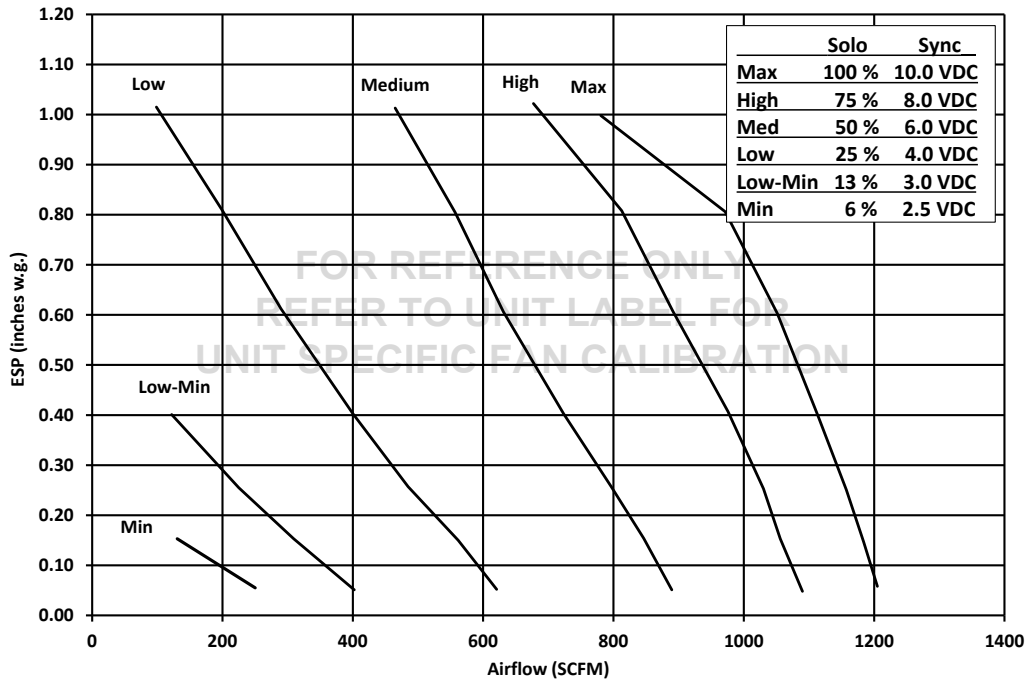

QUIET SERIES FLOW FAN POWERED FAN SIZE 10
 FAN CALIBRATION CURVE: 1-PHASE CONSTANT-TORQUE EC MOTOR
 No Filter, Fan Only

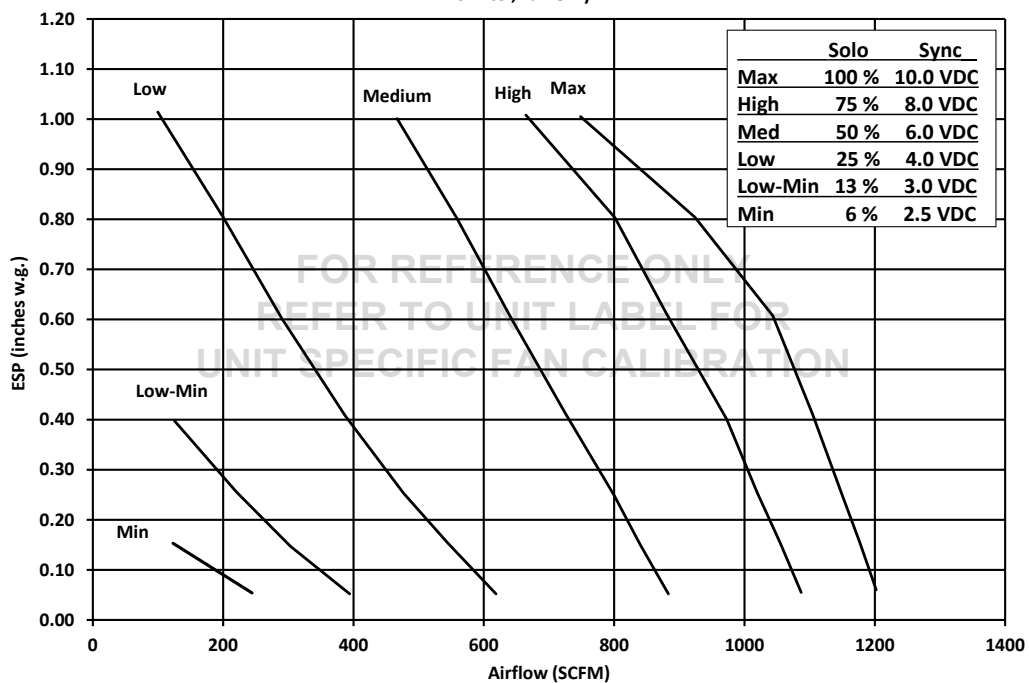

TERMINAL UNIT WEIGHTS

CRB (20 GA)						
BASE UNIT WEIGHT		ADDERS TO BASE UNIT WEIGHT				
SIZE	SINGLE WALL	WATER COIL				ELECTRIC HEAT
		1 ROW	2 ROW	3 ROW	4 ROW	
0407	109	12	15	18	21	25
0507	108	12	15	18	21	25
0607	107	12	15	18	21	25
0610	109	16	20	24	28	26
0612	149	19	24	30	35	28
0807	108	12	15	18	21	25
0810	110	16	20	24	28	26
0812	150	19	24	30	35	28
0815	153	19	24	30	35	28
1010	112	16	20	24	28	26
1012	152	19	24	30	35	28
1015	155	19	24	30	35	28
1020	161	23	30	37	43	31
1025	170	23	30	37	43	31
1215	157	19	24	30	35	28
1220	164	23	30	37	43	31
1225	174	23	30	37	43	31
1415	160	19	24	30	35	28
1420	166	23	30	37	43	31
1425	175	23	30	37	43	31

CRQ (20 GA)						
BASE UNIT WEIGHT		ADDERS TO BASE UNIT WEIGHT				
SIZE	SINGLE WALL	WATER COIL				ELECTRIC HEAT
		1 ROW	2 ROW	3 ROW	4 ROW	
0407	140	12	15	18	21	25
0507	139	12	15	18	21	25
0607	138	12	15	18	21	25
0610	140	16	20	24	28	26
0612	186	19	24	30	35	28
0807	139	12	15	18	21	25
0810	141	16	20	24	28	26
0812	187	19	24	30	35	28
0815	193	19	24	30	35	28
1010	143	16	20	24	28	26
1012	189	19	24	30	35	28
1015	195	19	24	30	35	28
1020	209	23	30	37	43	31
1025	210	23	30	37	43	31
1215	197	19	24	30	35	28
1220	212	23	30	37	43	31
1225	214	23	30	37	43	31
1415	200	19	24	30	35	28
1420	214	23	30	37	43	31
1425	215	23	30	37	43	31

FACTORY REPLACEMENT PARTS AND WARRANTY

Factory replacement parts should be used wherever possible to maintain the unit performance and operating characteristics and the testing agency listings. Replacement parts may be purchased through the local Sales Representative.

Contact the local Sales Representative before attempting any unit modifications. Any modifications not authorized by the factory could result in personal injury and damage to the unit and could void all ETL listings and factory warranties.

When ordering parts, the following information must be supplied to ensure proper part identification:

1. Complete unit model number
2. Unit hand connection (right or left hand) while facing the direction of airflow at the inlet
3. Complete part description including any part numbers

On warranty replacements, in addition to the information previously listed, the project CO# (customer order number) that appears on the unit nameplate, is required.

Contact your ENVIRO-TEC sales representative for authorization to return any parts such as defective parts replaced in warranty.

All equipment and components sold through ENVIRO-TEC are warranted under the same conditions as the standard manufacturer's warranty with the exception that the warranty period is 12 months unless the component is furnished as warranty replacement. Parts furnished as warranty replacements are warranted for 12 months from the replacement part ship date.

APPENDIX

COMPONENT INSTALLATION, OPERATION AND MAINTENANCE MANUALS

EC Motor Solo, Select, and Sync PWM Installation, Operation and Maintenance

Electric Heat Installation, Operation and Maintenance

Seismic VAV Products Installation, Operation and Maintenance

Configurable VAV DDC Controls

Quick Start Guide on ZEC5x0 Controller

ZEC5x0 Controller Sequence Definition Table

ZEC5x0 Controller Parameters and Factory Defaults Table

MAP Gateway Configuration User Tool - TL-CWCVT-0 (Largo p/n PC-01-0246) or prior TL-MAP1810-0P

Quick Start Guide - MAP Gateway

User Guide - MAP Access Portal Gateway

Mobile Access Portal (MAP) Gateway Installation, Operation and Maintenance

Wall Sensors For ZEC500 and ZEC510 Controllers

Thermostat Wall Sensors - BTN 041, 141, 241 Zone/Wall Thermostats

Catalog Pages - DDC VAV Controller Temperature Sensors For Operation With ZEC5x0 DDC Controllers

TE-6300 Discharge Air Temperature Sensor Installation, Operation and Maintenance

Return Air Sensor (For Operation With ZEC5x0 DDC VAV Controllers) Installation, Operation and Maintenance

For the supplemental Installation, Operation and Maintenance manuals listed above, please contact your local Sales Representative or visit www.enviro-tec.com.

For configurable VAV DDC Controls, MAP Gateway Tool Quick Start Guides, and related IOMs, visit www.enviro-tec.com

ENVIRO-TEC is a registered trademark of Johnson Controls in the United States of America and other countries.
Other trademarks used herein may be trademarks or registered trademarks of other companies.

Catalog: ET130.13-NOM6 (0225) Supersedes ET130.13-NOM6 (0421)
© 2025 Johnson Controls P.O. Box 423, Milwaukee, WI 53201
www.enviro-tec.com

