

MANUAL DAMPER OPTION

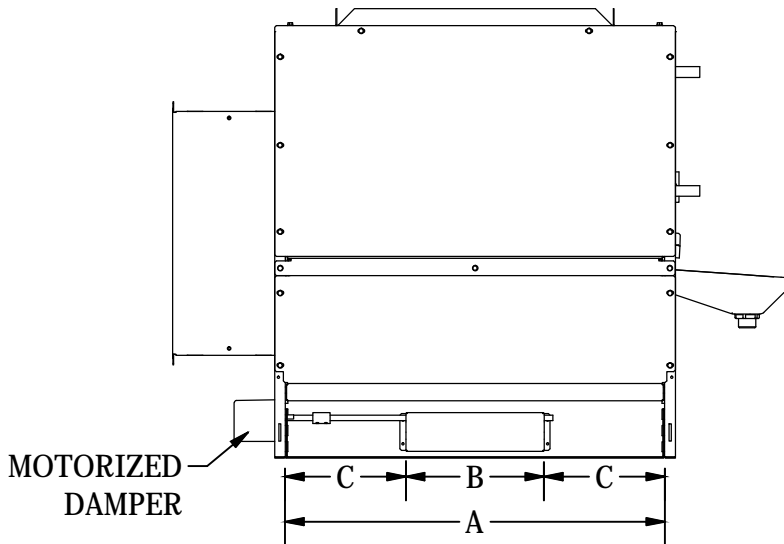

MOTORIZED DAMPER OPTION

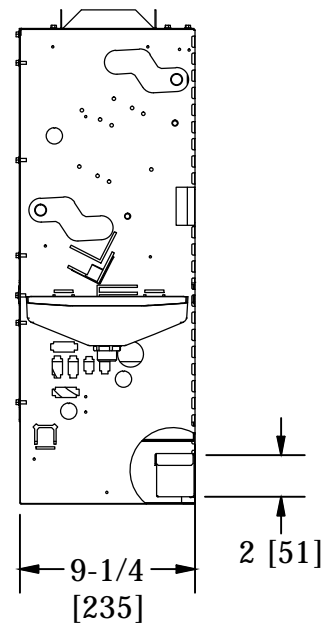
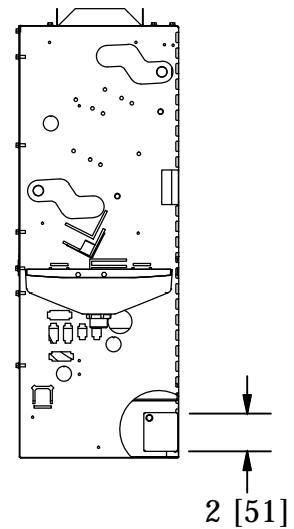

NOTES:

1. All dimensions are in inches [millimeters].
All dimensions are $\pm 1/4$ " [6mm]. Metric values are soft conversion.
2. Model VFC unit shown, typical for models "VFE" and "VFS" .
3. The standard damper options may not provide freeze protection under all conditions and applications. other forms of freeze protection may be required.
4. Right hand unit shown, left hand unit is similar but opposite.

DIMENSIONS - In [mm]			
UNIT SIZE	A	B	C
02	22 [559]	8 [203]	7 [178]
03	26 [660]	10 [254]	8 [203]
04	32 [813]	12 [305]	10 [254]
06	42 [1067]	14 [356]	14 [356]
08	44 [1118]	18 [457]	13 [330]
10	58 [1473]	27 [686]	15 1/2 [394]
12	66 [1676]	27 [686]	19 1/2 [495]

TITLE: MODEL VF OUTSIDE AIR INLET LOCATION SERIES C



DRN BY: CCC	DATE: 3/5/2010	SCALE: NA	DRAWING NO.
CKD BY:	DATE: 07/31/15	REV: 01	

THIS DRAWING CONTAINS PROPRIETARY DATA. UNAUTHORIZED DISCLOSURE, REPRODUCTION, OR USE IS STRICTLY PROHIBITED WITHOUT WRITTEN PERMISSION

DO NOT SCALE DRAWING
DIMENSIONS AND DATA ARE SUBJECT TO CHANGE WITHOUT NOTICE.
CONTACT FACTORY FOR CERTIFIED DRAWINGS.

51-80076