

NOTES:

1. All dimensions are Inches [millimeters]. All dimensions are $\pm 1/4"$ [6mm]. Metric values are soft conversion.
2. Junction box size and location varies with unit features. Control options may be limited. Provide sufficient clearance to access electrical controls and comply with applicable codes and ordinances.
3. Standard cabinet finish is "Pearl White Satin".
4. Parametric design available to increase Height or Width. (See parametric offerings drawing.)
5. Some control or piping package options may require extended end pockets and/or extended drain pans. (See extended end pocket drawing.)
6. False backs ship loose for field installation.

TABLE

Column	Column 2	Column 3	Column 4	Column 5	Column 6
UNIT MODEL	DIM A	DIM B	DIM C	DIM D	DIM E
02	41 [1041]	22 [559]	19 1/2 [495]	22 3/4 [578]	20 [508]
03	45 [1143]	26 [660]	23 1/2 [597]	26 3/4 [679]	24 [607]
04	51 [1295]	32 [813]	27 1/2 [699]	32 3/4 [832]	30 [762]
06	61 [1549]	42 [1067]	39 1/2 [1003]	42 3/4 [1086]	40 [1016]
08	63 [1600]	44 [1118]	39 1/2 [1003]	44 3/4 [1137]	42 [1067]
10	77 [1956]	58 [1473]	55 1/2 [1410]	58 3/4 [1492]	53 [1347]
12	85 [2159]	66 [1676]	63 1/2 [1613]	66 3/4 [1695]	64 [1626]

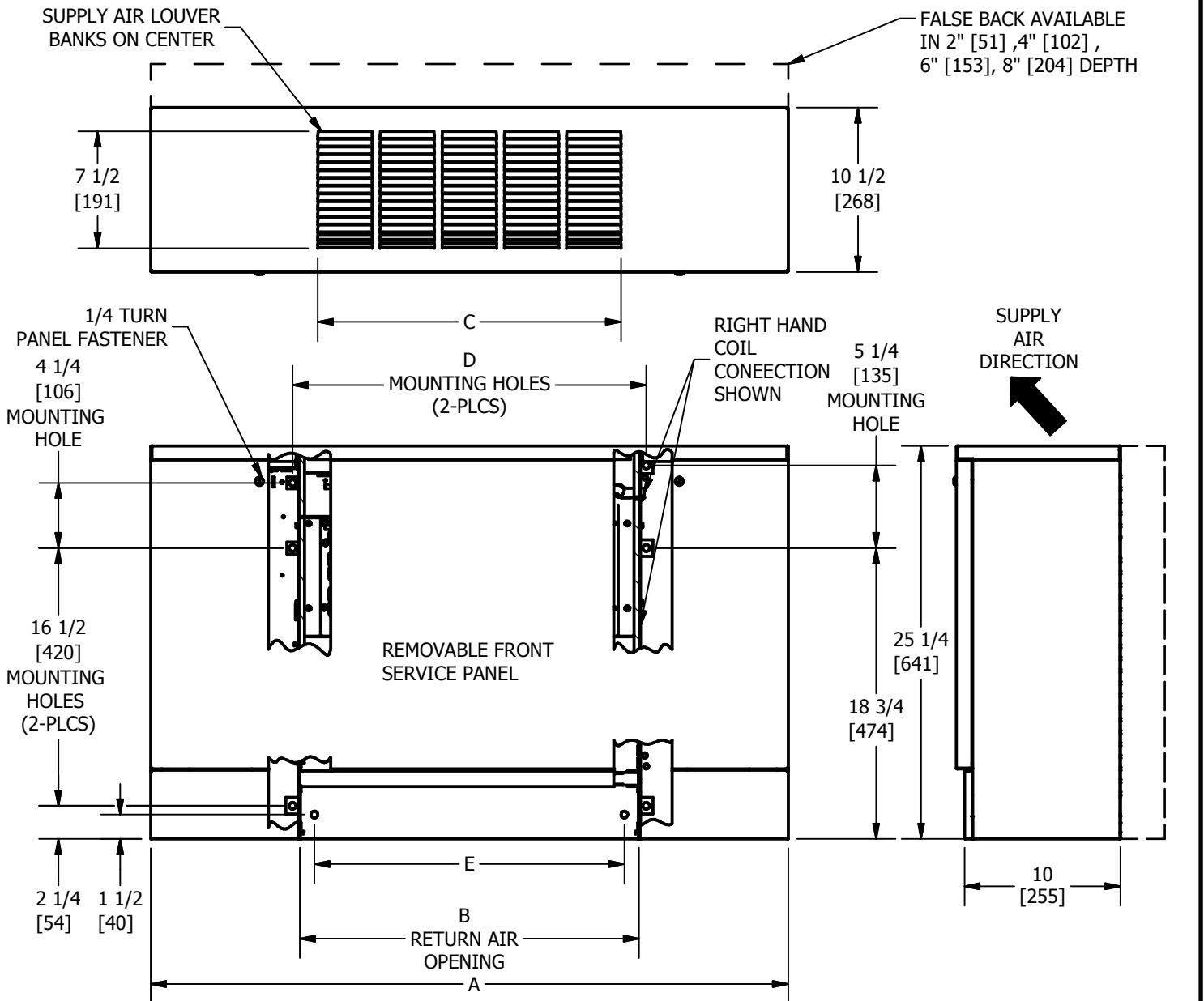

	TITLE			MODEL VFE,FALSE BACK, SERIES C	
	DRN BY AJM	DATE 08/06/15	SCALE N/A	DRAWING NO.	
CKD BY ML	DATE 08/06/15	REV 02	51-80088		

THIS DRAWING CONTAINS PROPRIETARY DATA, UNAUTHORIZED DISCLOSURE, REPRODUCTION, OR USE IS STRICTLY PROHIBITED WITHOUT WRITTEN PERMISSION

DO NOT SCALE DRAWING
DIMENSIONS AND DATA ARE SUBJECT TO CHANGE WITHOUT NOTICE. CONTACT FACTORY FOR CERTIFIED DRAWINGS.