

NOTES:

1. All dimensions are Inches [millimeters]. All dimensions are $\pm 1/4"$ [6mm]. Metric values are soft conversion.
2. Right hand unit shown, left hand unit opposite. Motor/drive location may be specified Left or Right Hand. Standard control enclosure location matches motor/drive position.
3. Provide sufficient clearance to permit access to controls and comply with applicable codes and ordinances.
4. See drawing FR-001 for filter rack details.
5. Outside and return air damper linkage is optional.
6. See coil connection detail drawings for coil connection sizes and locations.
7. High efficiency filter rack not available with mixing box.
8. Units with electric heat only (No chilled water, DX, hot water or steam coils) and a drain pan will be supplied with condensate drain outlet the same side as the electric heat control enclosure.

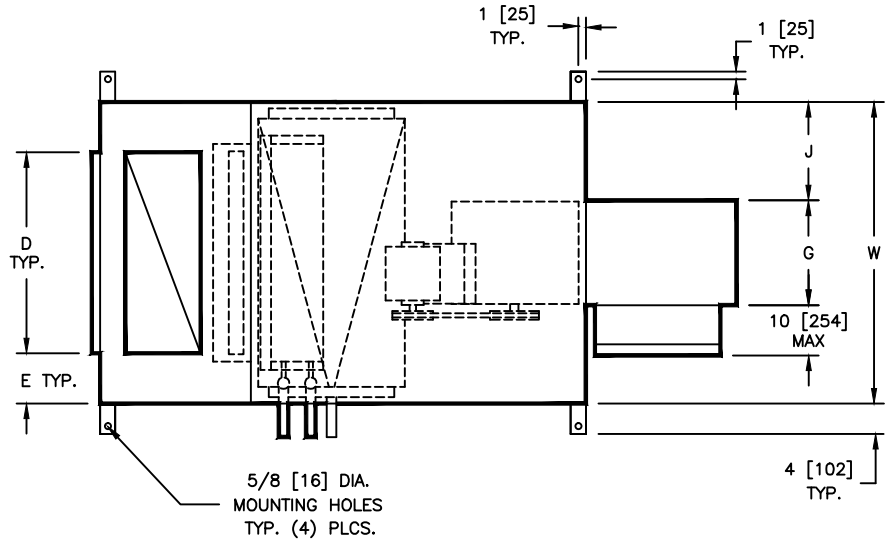

TOP VIEW

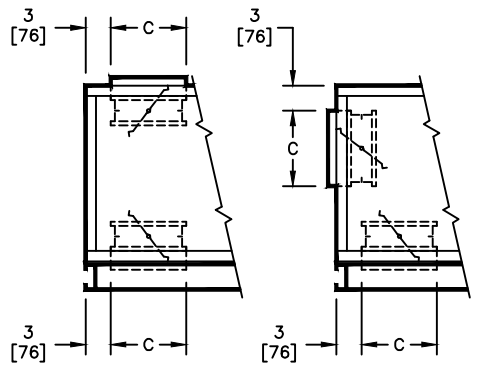

TOP/BTM INLET

REAR/BTM INLET

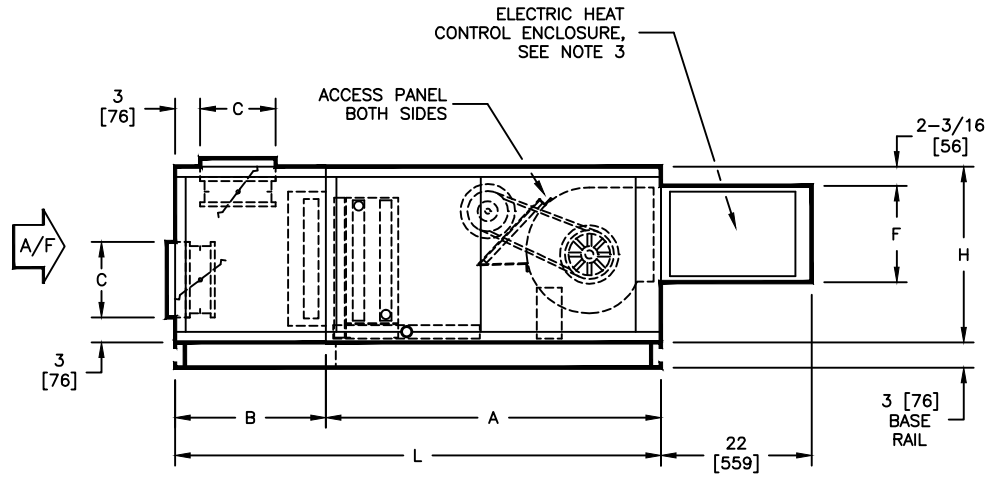

REAR/TOP INLET

SIDE VIEWS

DIMENSIONS

SIZE	FAN SIZE	L	W	H	A	B	C	D	E	F	G	J
08	9 X 4 [229 X 102]	58 [1473]	30 [762]	21 [533]	40 [1016]	18 [457]	9 [229]	18 [457]	6 [152]	11-7/8 [302]	8-7/8 [225]	10-9/16 [268]
12	9 X 6 [229 X 152]	58 [1473]	36 [914]	21 [533]	40 [1016]	18 [457]	9 [229]	24 [610]	6 [152]	11-7/8 [302]	8-7/8 [225]	13-9/16 [344]
16	10 X 8 [254 X 203]	58 [1473]	44 [1118]	21 [533]	40 [1016]	18 [457]	9 [229]	30 [762]	7 [178]	12 [305]	10-7/8 [276]	16-9/16 [421]
20	10 X 10 [254 X 254]	61 [1549]	50 [1270]	21 [533]	40 [1016]	21 [533]	12 [305]	36 [914]	7 [178]	12 [305]	13-7/8 [352]	18-1/16 [459]
30	15 X 9 [381 X 229]	67 [1702]	59 [1499]	30 [762]	46 [1168]	21 [533]	12 [305]	45 [1143]	7 [178]	16-5/8 [422]	13-7/8 [352]	22-9/16 [573]
40	15 X 11 [381 X 279]	70 [1778]	68 [1727]	30 [762]	46 [1168]	24 [610]	15 [381]	48 [1219]	10 [254]	16-5/8 [422]	15-5/8 [397]	21-11/16 [551]

TITLE:

MODEL H SERIES C
BELT DRIVE BLOWER COIL UNIT
BASIC UNIT - DISCHARGE ARG. 3
W/ MIXING BOX & BLOW-THRU ELECTRIC HEAT



DRN BY: JCI	DATE: 09/08/09	SCALE: 1=22	DRAWING NO.
CKD BY: DPB	DATE: 07/31/15	REV: 02	

35-80012

THIS DRAWING CONTAINS PROPRIETARY DATA. UNAUTHORIZED DISCLOSURE, REPRODUCTION, OR USE IS STRICTLY PROHIBITED WITHOUT WRITTEN PERMISSION

DO NOT SCALE DRAWING
DIMENSIONS AND DATA ARE SUBJECT TO CHANGE WITHOUT NOTICE.
CONTACT FACTORY FOR CERTIFIED DRAWINGS.